



Accelerated Bridge Construction Applications in California

A Lessons Learned Report

August 2008
Version 1.1

Accelerated Bridge Construction Applications in California- A “Lessons Learned” Report

Editors:

Paul Chung, P.E.
Raymond W. Wolfe, Ph.D., C.E., M.E.
Tom Ostrom, P.E.
Susan Hida, P.E.

Contributing Authors:

Paul Chung, P.E.
Daniel Speer, P.E.,
Aaron Franklin, P.E.,
Mazen Wahbeh, Ph.D., P.E.,
Martin Pohll, P.E., S.E.

Tariq Masroor, P.E,
Linan Wang, P.E,
Peter Soin, P.E.,

Ahmed M. M. Ibrahim,
Ph.D, S.E, P.E,
Don Nguyen-Tan, PE,
Jim Ma, PE,
Mike Pope, PE

TABLE OF CONTENTS

1. INTRODUCTION.....	1
2. CASE STUDIES- EMERGENCY PROJECT DELIVERY	2
2.1 I-40 BRIDGES (REPLACE).....	2
2.1.1 <i>Project Background</i>	2
2.1.2 <i>Project Goals</i>	2
2.1.3 <i>ABC Implementation</i>	3
2.1.3a <i>Design</i>	3
2.1.3b <i>Construction</i>	3
2.1.4 <i>Challenges</i>	5
2.1.5 <i>Lessons Learned</i>	6
2.2 OAKLAND EASTBOUND I-580 CONNECTOR (REPAIR).....	6
2.2.1 <i>Project Background</i>	6
2.2.2 <i>Project Goals</i>	7
2.2.3 <i>ABC Implementation</i>	9
2.2.3a <i>Planning and Design</i>	9
2.2.3b <i>Contracts and Construction</i>	11
2.2.4 <i>Challenges</i>	14
2.2.5 <i>Lessons Learned</i>	14
2.3 I-5 SOUTHBOUND TRUCK ROUTE UNDERCROSSING (REPAIR)	16
2.3.1 <i>Project Background</i>	16
2.3.2 <i>Project Goals</i>	17
2.3.3 <i>ABC Implementation</i>	17
2.3.4 <i>Challenges</i>	19
2.3.5 <i>Lessons Learned</i>	19
2.4 RUSSIAN RIVER BRIDGE (REPLACE)	20
2.4.1 <i>Project Background</i>	20
2.4.2 <i>Project Goals</i>	20
2.4.3 <i>ABC Implementation</i>	20
2.4.3a <i>Design</i>	20
2.4.3b <i>Cost-Reduction-Incentive-Proposal (CRIP)</i>	22
2.4.3c <i>Construction</i>	23
2.4.4 <i>Challenges</i>	25
2.4.5 <i>Lessons Learned</i>	25
3. CASE STUDIES- PLANNED PROJECTS	26
3.1 SAN FRANCISCO YERBA BUENA ISLAND VIADUCT (REPLACE)	26
3.1.1 <i>Project Background</i>	26
3.1.2 <i>Project Goals</i>	26
3.1.3 <i>ABC Implementation</i>	26
3.1.3a <i>Design</i>	26
3.1.3b <i>Construction</i>	27
3.1.3c <i>Roll-in Operation</i>	28
3.1.4 <i>Challenges</i>	30

3.1.5	<i>Lessons Learned</i>	30
3.2	ROUTE 99/120 SEPARATION BRIDGE (REPLACE)	31
3.2.1	<i>Project Background</i>	31
3.2.2	<i>Project Goals</i>	31
3.2.3	<i>ABC Implementation</i>	33
3.2.3a	<i>Design</i>	33
3.2.3b	<i>Construction</i>	34
3.2.4	<i>Challenges</i>	36
3.2.5	<i>Lessons Learned</i>	38
3.3	HILLTOP DRIVE OVERCROSSING (WIDEN)	38
3.3.1	<i>Project Background</i>	38
3.3.2	<i>Project Goals</i>	38
3.3.3	<i>ABC Implementation</i>	38
3.3.4	<i>Challenges</i>	42
3.3.5	<i>Lessons Learned</i>	42
4.	TECHNICAL RESEARCH AND DEVELOPMENT	43
4.1	TECHNICAL DEVELOPMENT	43
4.2	TECHNICAL RESEARCH	43
5.	CONCLUSION AND RECOMMENDATIONS	44
5.1	EMERGENCY BRIDGE PROJECT DELIVERY	44
5.2	NON-EMERGENCY ABC PROJECTS	46
5.3	ACCELERATED BRIDGE CONSTRUCTION TECHNOLOGIES GUIDE- CURRENT PRACTICE	48
	REFERENCES:	55

1. INTRODUCTION

The ever-increasing demands placed on the transportation network across the nation, coupled with the aging infrastructure, have led to the omnipresent need to rapidly replace, widen, and build new highway infrastructure, including bridge structures. Due to rapid economic and population growth, transportation planners are under increasing pressure to improve highway and bridge systems under added constraints of accelerated project delivery time.

The vast majority of structures constructed in California require substantial design and construction effort, leading to extended project development and construction completion time. Recently, with pressures mounting to complete transportation improvement projects quickly, the California Department of Transportation (Caltrans) has begun investigating viable alternative engineering practices to conventional construction. To achieve accelerated bridge construction (ABC) that reduces on-site construction time and mitigates long traffic delays, Caltrans engineers are developing new practices to design alternative bridge types using precast, segmental, and steel structure types.

In California, cast-in-place (CIP) construction has been the mainstay (“bread-and-butter”) practice for the majority of bridges. This structure type yields construction cost effectiveness and predictable seismic performance. Typical CIP operation needs extensive preparatory, casting and finishing time, and usually many concrete bridges require complex falsework systems, which adversely affects traffic movement during construction. In an effort to address accelerating bridge construction, the California Department of Transportation (Caltrans) has begun to investigate and deploy viable alternatives to conventional construction. In light of the increasing pressure to accelerate work, alternative designs that expedite the delivery of a bridge in construction are receiving more attention than in the past. ABC could mean expedited design efforts to accommodate longer duration construction yet delivering the project sooner. Alternatively, and more widely recognized as the definition, it means techniques/methods that significantly reduce on-site construction time. Alternative approaches include precast or prefabricated structural elements, fabricating the structure nearby on-site and moving into place using self propelled modular transporters (SPMTs) or other hydraulic means including launching, and segmental construction methods.

Prefabricated elements reduce overall on-site construction time, and also eliminate the need for falsework, thereby mitigating impacts to the traveling public. In addition, prefabricated components, when produced in a manufacturing facility or off-site, enhance quality control of the product. In California, prefabricated elements, such as precast concrete girders, abutments, steel girders, and others, currently lead the discussion of ways to accelerate on-site project completion.

Since 2006, several events have occurred in California requiring Caltrans to incorporate ABC technologies in specific projects. These projects were carried out successfully and provided a template and motivation for increasing widespread application of ABC projects in the future. This report highlights, documents, and evaluates recent projects that have employed ABC techniques and practices. These cases are evaluated for the effectiveness and challenges of the various ABC practices employed. Subsequent recommendations are presented for future ABC applications.

2. CASE STUDIES- EMERGENCY PROJECT DELIVERY

2.1 I-40 Bridges (Replace)

2.1.1 Project Background

A biennial maintenance inspection early in 2006 revealed severe deterioration on six pairs of left and right T-beam bridges clustered along a twenty-mile stretch of I-40, located eighty miles east of Barstow, California. The replacement of twelve bridges on the heavily traveled I-40 corridor in southeastern California was required immediately and a project was initiated. Signs of deterioration included deck delamination, as well as shear cracking in the bent caps and several girders. Emergency shoring was installed to maintain a single lane of traffic on each bridge, while designs were completed for the structures located on the eastbound lanes first. The I-40 Bridge Replacement project demonstrated ABC by utilizing precast girders and abutments.

2.1.2 Project Goals

The heavily traveled route demanded accelerated construction to replace the damaged bridges. The first phase of the project rerouted eastbound traffic to the westbound lanes with two detours: one wrapping around the bridge at Marble Wash Bridge (Right) [Br. No. 54-1274], and the second encompassing the remaining five structures. Since the Marble Wash bridges were nearly ten miles separated from the remaining affected structures, the two-part detour assisted in alleviating traffic congestion by providing an intermediate passing lane within the project limits. Upon completion of the six structures on the eastbound roadbed, traffic was rerouted off the westbound road and the six damaged structures were then replaced. The second phase of the work was accelerated at the Marble Wash Bridge (Left) to reduce the traffic impacts of the second detour.

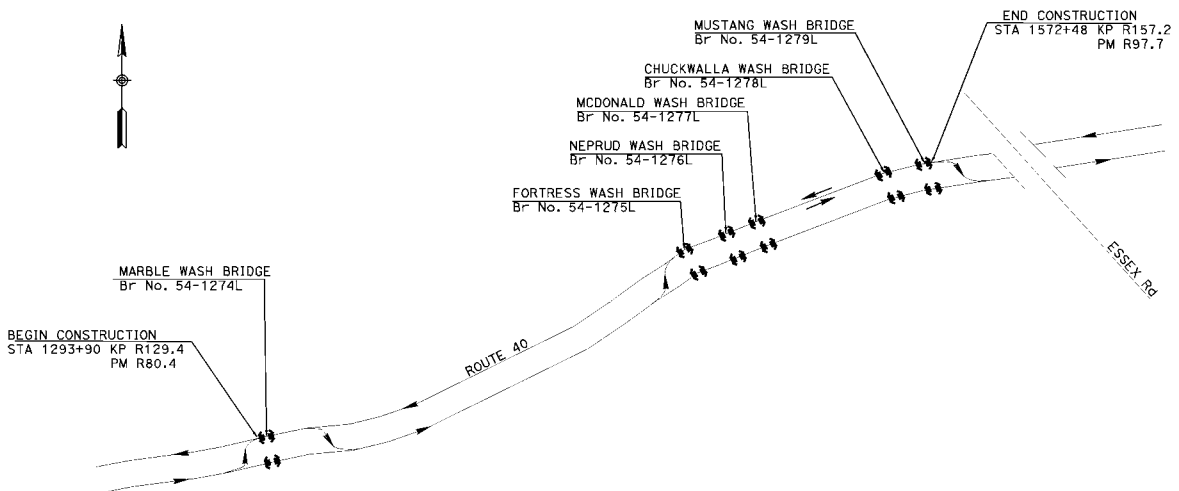

Figure 2.1.1. Project Map

2.1.3 ABC Implementation

2.1.3a Design

The challenge to the bridge engineers was to devise plans that emphasized accelerated construction. Precast girders were specified for all twelve structures to accommodate concurrent construction activities. The girders were designed to accommodate the additional dead load of stay-in-place deck forms to expedite cast-in-place deck construction. Precast deck panels were considered, but discounted due to concerns over girder camber and connection details. Where plausible, both I- and bulb-T girders were specified at several locations to allow the fabricator to fully utilize the precast yard capacity. However, not all structures could be economically designed with both girder options. Single-span precast girder structures replaced existing two-span structures at locations where hydraulic freeboard could be maintained with deeper sections. This solution eliminated the need to construct the center bent columns and footings, and thus saved construction time. However, the longer span exceeded the capacity of standard I-girders, requiring bulb-T sections.

In an effort to mitigate traffic impacts during reconstruction of the westbound structures, an innovative strategy was employed at the detour around the Marble Wash Bridge (Left). The idea was to precast as much of the structure as necessary to expedite on-site construction. The existing two-span, 106-foot long bridge was replaced with a single-span structure designed to reduce substructure construction efforts. Furthermore, site geology permitted the use of spread footings, thereby facilitating a precast abutment solution. The advantage of this strategy was that the abutments could be placed and the girders set soon thereafter.

2.1.3b Construction

Girder fabrication was completed at established precast yards off-site while concurrent demolition and substructure work commenced in the field. Installation of rock slope protection beneath the structure to protect the abutment footings from scour was the only factor disallowing immediate placement of the girders once the abutments were set. Specifications were written to not permit the detour at the Marble Wash Bridge (Left) location until the precast abutments and girders were cast. The detour was then implemented, demolition operations commenced, and the abutment subgrade prepared to receive the precast abutment. Additionally, the specifications limited the duration of the detour at this location, forcing the Contractor to shift forces from other operations as necessary to expedite opening of the westbound roadbed crossing the new bridge at Marble Wash.

The precast abutments were cast as whole-width pieces fabricated in a casting yard in Perris, California. Each piece, weighing 82 tons, was hauled by a special permit truck to the bridge job site. A 500-ton crane was used to lift and place the precast abutments; a 360-ton crane could have been used considering the load and crane position relative to the pick and placement of the abutment section, but one was

Table 2.1.1. Structure Type Data

Structure Type	Precast bulb-T girders
Spans	Single-span: 106 ft, total width= 42.88 ft
Structure Depth	6.0 ft depth/span ratio = 0.057
Deck Type	CIP concrete, thickness=7.8 in
Alignment	Tangent horizontal alignment
Abutments	Single-span: Precast abutment on spread footing Two-spans: CIP abutment on spread footing
Bents	Two-spans: CIP
Foundation Type	Spread footing
Vertical Clearance	15.26 ft
Temporary Vertical Clearance	15.26 ft
Barriers	Type 736 Mod
Slope Paving	N/A
Temp Range	-2°C to 44°C (28°F-112°F)
Utilities	N/A
Skew	30-deg and various

not readily available. Cast-in-place concrete for a footing shear key, the abutment backwall, the abutment shear keys, and the approach fill wingwalls were used but had a minimal affect on the overall construction schedule. These latter operations proceeded simultaneously with the cast-in-place concrete deck construction.

Site preparation to accept precast abutments can be accomplished in two forms; utilizing leveling screw attachments on the precast abutment element with post grouting beneath the abutment footing to ensure uniform load distribution to the soil, or placement of a low strength slurry pad designed to crush at interface high points when the abutment is placed. The Marble Wash Bridge (Left) employed the latter with a 200 psi slurry pad.



Figure 2.1.2. Photos of Precast Abutment Placement

In the end, the detour at the Marble Wash Bridge (Left) was removed after only twenty-eight days. The remaining structures on the westbound roadbed were completed and the road opened to traffic in only three months. The project was a huge success and set the stage for more innovative uses of prefabricated components to reduce construction traffic delays.

2.1.4 Challenges

The precast abutments were whole-width structures. The heavier of the two weighed approximately 82-tons, requiring transport permits and a larger crane for lifting than might otherwise be found on a similar transportation project of this size. Obtaining the large crane required for the abutment weight and working radius was one of the bigger challenges of this project. The crane's location and working radius were controlled by a cut slope of 1.5:1 from the abutment excavation.



Figure 2.1.3. Photos of Precast Abutment Placement



Figure 2.1.4. Photos of Precast Girders Placement

Because of weight limitations and construction considerations, only the abutment seat and a portion of the footing were precast. The footing and abutment shear keys, the abutment backwall, and the approach fill wingwalls were all cast-in-place components.

2.1.5 Lessons Learned

Precast structures can successfully accelerate bridge construction. The main challenge is to keep the precast pieces within a practical weight range for transporting, picking, and placing.

An abutment cast in segment would reduce or eliminate the need for securing transport permits, lessen the premiums paid for trucking fees, and allow the use of cranes already expected on-site for other operations, such as setting girders. Another key advantage to segmenting precast abutment design is that bridges can be built in stages, with traffic allowed on earlier stages while existing structure is demolished.

2.2 Oakland Eastbound I-580 Connector (Repair)

2.2.1 Project Background

The Oakland I-580/880 Connector repair is another demonstration of a successful ABC project in California. The Bay Area has been ranked as the second most congested urban area in the nation [1]. The MacArthur Maze Interchange has been ranked among the Bay Area’s busiest freeways by local transportation officials [2]. Located just east of the San Francisco-Oakland Bay Bridge (hereinafter referred to as the Bay Bridge), the MacArthur

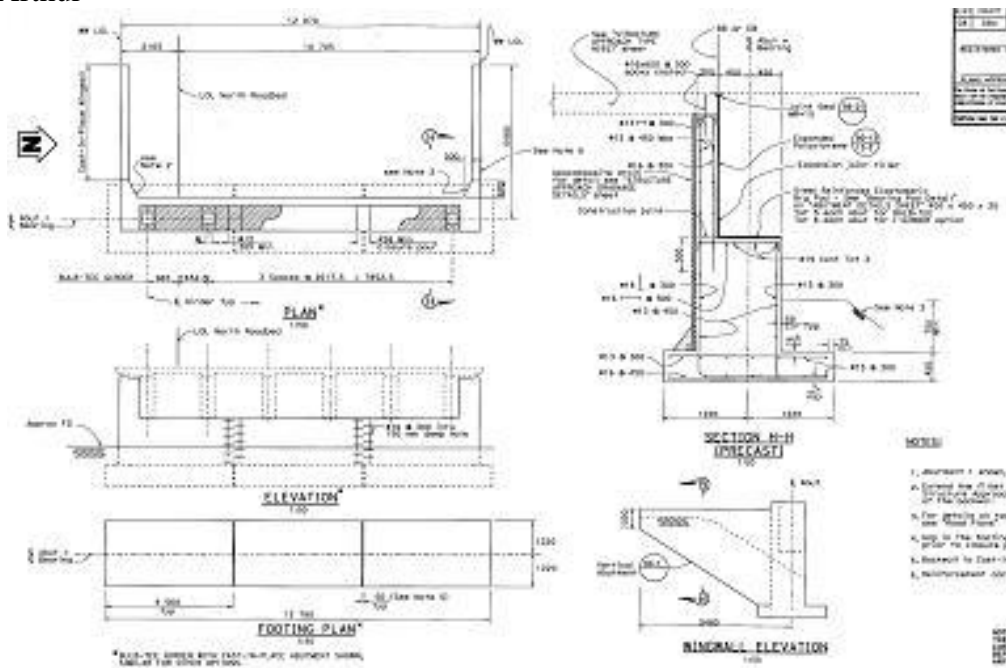

Figure 2.1.5. Precast Segment Abutment Details

Maze consists of four separate interchanges between Interstates 880, 80, 580, 980, and California State Route 24. The interchange of interest is called the Distribution Structure, which consists of eastbound I-580 and southbound I-880 connector structures. The eastbound I-580 carries three lanes of vehicular traffic from the Bay Bridge to State Route 24 and the Caldecott Tunnel. The southbound I-880 carries two lanes of traffic and connects cities to the north of the Bay Bridge with cities to the south.

At 3:41 a.m. on April 29, 2007, a fuel tanker truck traveling southbound from I-80 to I-880 overturned and exploded. According to police reports, the accident occurred when the driver changed lanes and the fuel shifted from one side to the other, tipping the truck. The explosion and fire occurred on the bridge deck of southbound I-880 [Br. No. 33-0611L] and beneath the connector ramp from the Bay Bridge to eastbound I-580 [Br. No. 33-0061L]. The extreme heat (2000 to 3000 degrees F) from the free burning gas fire caused the steel box beam bent cap at Bent 19, as well as spans 18 and 19 on I-580 to buckle and collapse onto the I-880 connector ramp directly below. The resulting flames destroyed two spans of the upper connector structure and the collapsed spans landed on the lower I-880 Bridge, thus stopping traffic from passing thru.

At all levels, Caltrans management and government officials reacted immediately and decisively to prioritize reconstruction. Within hours, bridge officials were meeting to set priorities and engineers were onsite assessing the damage. By the end of the first day, the Governor of California had declared a State of Emergency and had procured federal support for emergency reconstruction funds. Immediately after removal of debris and stabilization of the structure, steel and concrete samples were obtained. After testing, Caltrans Engineers determined that the I-580 superstructure, which remained standing, was not severely heat damaged with exceptions at the upper columns. Caltrans engineers also determined that the I-880 structural damage could be repaired..

Temporary supports were installed to shore the I-880 steel girders and deck. Within a few weeks, the girders were heat straightened, the top deck was overlaid with polyester concrete, and the column cover was replaced on the lower I-880 structure. Traffic then was opened on the lower connector. As a result, the primary outstanding work was to replace the collapsed section of the I-580 structure.

2.2.2 Project Goals

The collapse of these structures had a significant impact on the entire Bay Area because the I-580 connector is a vital link between Oakland and San Francisco. The city of Oakland was especially affected, since detours were required through their city streets. The loss of the connector was estimated to have a total economic impact to the Bay Area of \$6 million dollars a day [3]. The heavily used connector linking Oakland and San Francisco demanded accelerated construction to replace the damaged spans in the shortest time. The initial Caltrans goal was to re-open I-580 before the July 4th holiday.



Figure 2.2.1. Aerial Photo of Collapsed Portion of MacArthur Maze

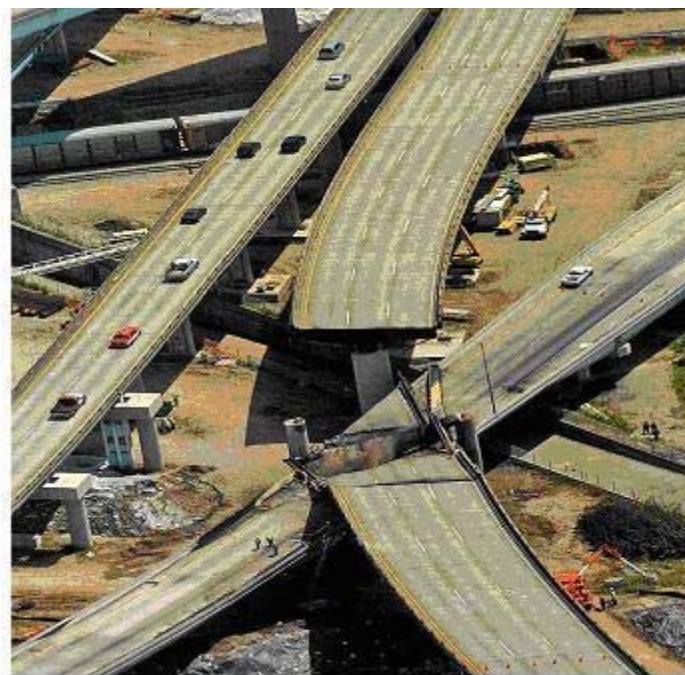

Figure 2: View of damage from above

Figure 2.2.2. Aerial Graphic of Collapsed I-580 Span

2.2.3 ABC Implementation

2.2.3a Planning and Design

Caltrans Engineers realized that rebuilding quickly would hinge on the availability of materials and securing the right contractors. On the day of the accident, Caltrans began a worldwide search to assess steel availability and fabrication capabilities. This information, gathered within two days, became a critical guide for engineers selecting the reconstruction alternatives.

The collapsed portion of the I-580 encompassed the steel girders on both sides of the Bent 19 as well as the bent cap itself. The affected section was 160 feet long and 51 feet wide. The structure consisted of steel stringers with a reinforced concrete deck supported by column bents with steel caps. In 1993 and 2001, Caltrans retrofitted the portion of the I-580 structure to seismic standards by adding steel column casings and bridge joint restrainer brackets.

Caltrans determined that the girders, bent cap, and deck were the primary items requiring replacement. Steel girders like those in the original design were the preferred option if the steel could be located quickly. Engineers considered precast concrete girders, but decided against this idea because foundation enhancement would be required to support the additional weight.

Caltrans engineers also allowed a precast prestressed concrete bent cap or a steel box bent cap alternative. The final decision on the bent cap type was left to the Contractor. A steel bent cap design required fracture critical fabrication, use of certified steel plate, and additional inspection. This likely would have lengthened the project for material procurement difficulties and stringent fabrication requirements. Thus, the Contractor opted for a concrete bent cap.

To meet the tight project schedule, designers had to make quick decisions taking into consideration several factors. These included:

- A. Design that could be easily fabricated with currently available materials;
- B. Fast fabrication time to minimize structure closure;
- C. Shoring design of the lower structure to provide a platform for reconstructing the upper structures.

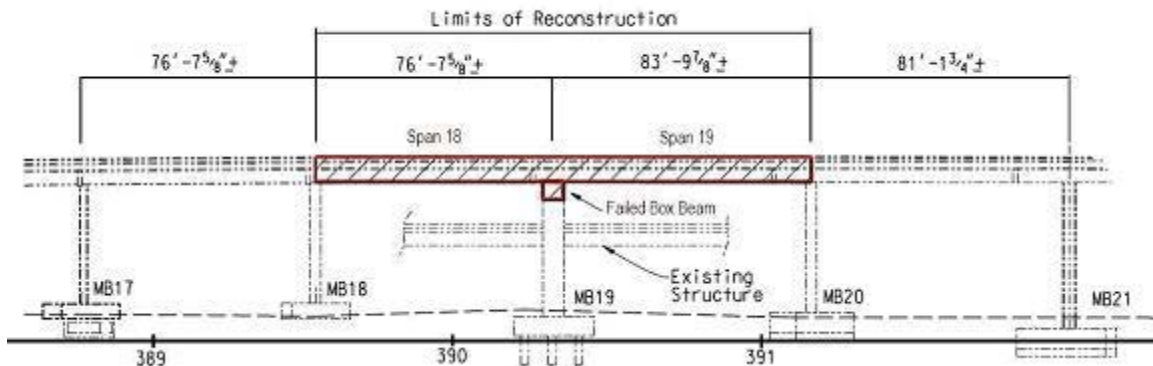

Figure 2.2.3. East-bound I-580 General Elevation View

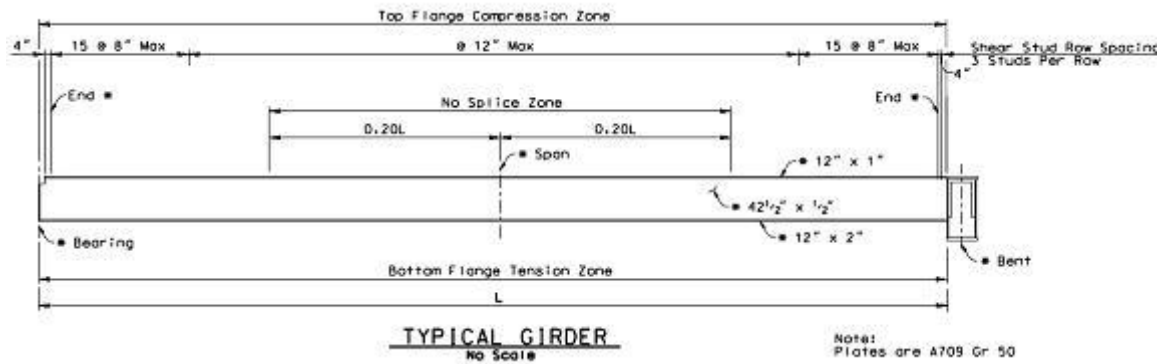

Figure 2.2.4. Typical Steel Girder Elevation

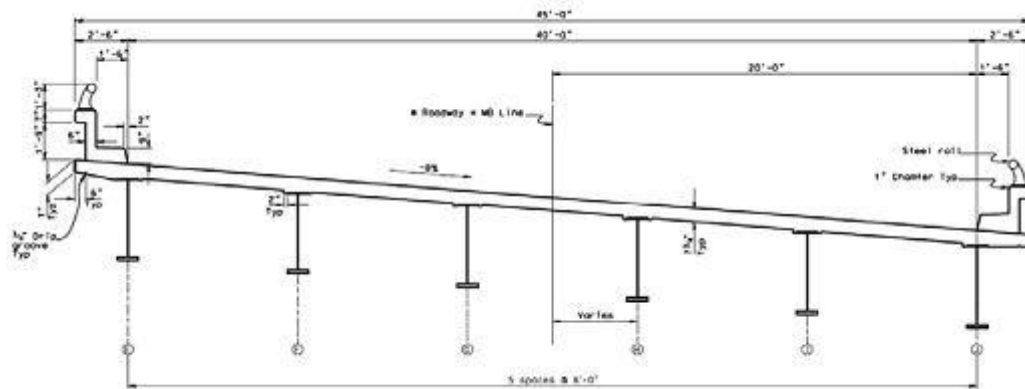

Figure 2.2.5. Typical Steel Girder Section

Table 2.2.1. Structure Type Data

Structure Type	Plate girders - simple supports
Spans	Two-span, 77 ft, 84 ft, total width= 45 ft
Structure Depth	4.5 ft depth/span ratio = 0.052
Deck Type	CIP concrete w/ stay-in-place form, thickness= 7.7 in
Alignment	Curved horizontal alignment (R= 1100 ft)
Abutments	N/A
Bents	Precast post-tensioned concrete bent cap
Foundation Type	Exist CIDH pile shaft
Vertical Clearance	15.5 ft
Temporary Vertical Clearance	15.5 ft
Barriers	Type 26
Slope Paving	N/A
Temp Range	-2°C to 44°C (28°F-112°F)
Utilities	N/A
Skew	None

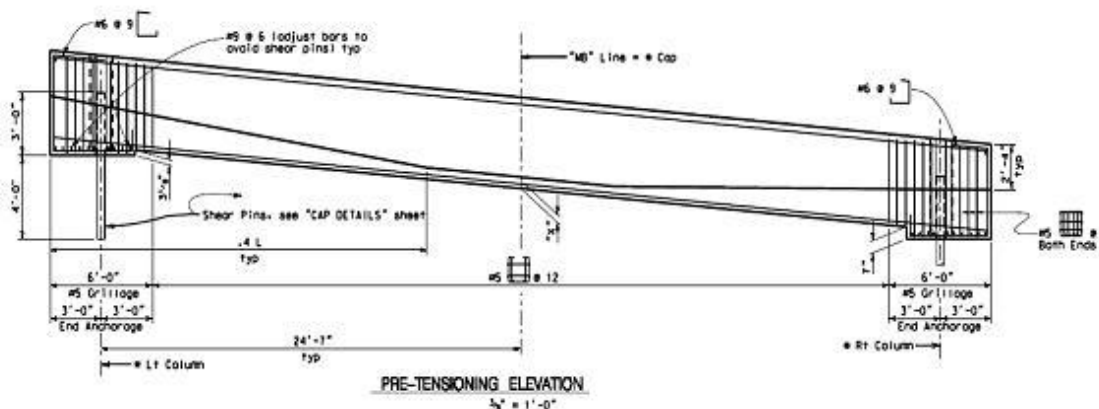

Figure 2.2.6. Elevation of Concrete Bent Cap

The designers worked fabrication experts during design, allowing delivery of a fast and safe design. The design team compared prefabricated rolled shapes with built-up sections. However, the required rolled shape sizes were not known to be readily available and would have required several weeks for fabrication. Hence the design team decided to proceed with built-up sections. In addition, the girder web thicknesses were increased to reduce the number of stiffeners required for local buckling checks and the amount of welding required on the built-up girders. The flange plates were kept to one size to simplify the fabrication. The web depth was adjusted to ensure that the overall depth would not require adjustment of the existing bearings that were to be reused.

Caltrans Structure Design started the design process and delivered a preliminary set of drawings to the Structures Office Engineer on the morning of May 2 to produce the structure bid specifications and estimates. A constructability review meeting followed in the afternoon where all functional units provided input to the final design. The final plans, specifications and estimates were completed in the afternoon of Wednesday May 2, and the project was advertised on Thursday May 3, 2007.

2.2.3b Contracts and Construction

Caltrans had decided on an invitation-only bid and was able to shorten the advertising time. Caltrans organized a pre-bid conference at the job site on May 5 and provided immediate responses to all bidder inquiries during the advertising period. Three addendums were issued and the Engineer's Estimate for the project was \$5,140,070. The bids were opened on May 7, 2007 and the contract was awarded on the same day to C.C. Myers for a cost of \$867,075.

The implementation of significant changes to typical construction contracts contributed to the project's success. Caltrans was motivated to complete the project as safely and quickly as possible. As a result the project was advertised with a \$200,000 per day incentive/disincentive clause capped at \$5,000,000 to reward contractor innovation. In addition, the contractor would be fined \$200,000 for every ten minutes that lane closures were picked up late.

Caltrans issued a construction contract which specified that Caltrans engineers would have only 24 hours to respond to all submittals and requests from the Contractor

(typical response times range from several days to several weeks, depending on the submittal type). To provide a comprehensive yet expedited review, Caltrans significantly increased the number of staff assigned to review teams and reduced the response time to a single day. Within two hours of contract award to C.C. Myers, Caltrans immediately initiated contact to begin discussing the steel fabricator's first critical path item before fabrication. Within 24 hours of contract award, Caltrans had a senior reviewer from the Materials Engineering and Testing Services subdivision (METS) full-time at the fabricator's shop to provide immediate guidance for welding and shop plans. In order for Caltrans to meet the one-day review times, Caltrans Engineers directly solicited draft copies of all welding submittals. In this way, Caltrans provided the fabricator immediate feedback, often before the official copy was even submitted.

Three days after contract award, Caltrans and C.C. Myers representatives conducted a Pre-welding Meeting at Stinger Welding's facility, the steel fabricator. Caltrans provided Stinger Welding with review comments on their Welding Quality Control Plan, to which the fabricator was able to provide a timely response. By the end of this meeting, Caltrans officials were satisfied with the fabricator's plan and fabrication began.

On the shop floor, Caltrans maintained a constant presence of Quality Assurance Inspectors, which proved to be critical to the success of steel girder fabrication. Designer availability at all hours of the day allowed materials engineers to quickly work through any issues that arose. Onsite Caltrans inspectors quickly elevated and addressed any issues that could potentially delay fabrication

Another key factor to the project success was a new Caltrans process that was recently implemented where fit-for-purpose decisions could be made. This process was managed by a materials engineer who was dedicated to the project and charged with seeking proposals from the fabricator and Contractor, making a fit-for-purpose



Figure 2.2.7. Girder Fabrication at Stinger Welding

determination on the Contractor's proposal, and gathering input and concurrence from the appropriate authorities. With this process, when it is in the best interest of Caltrans to accept the Contractor's proposal, a decision can be rapidly made and documented. Under this new program, Caltrans was able to use material with minor deviations, but none-the-less acceptable to all parties.

The concrete deck was designated by a 96-hour compressive strength of 3600 psi prior to directly supporting construction loads. The 96-hour limit allowed the deck to be poured and completed on a fast track and allowed the bridge to re-open earlier than originally scheduled.

The Caltrans contract set a construction completion deadline of re-opening I-580 on June 27. The contractor was able to complete the work on May 24, 2007, and the freeway was opened to traffic at 8:45pm that day, completing the construction in merely 20 days.



Figure 2.2.8. Completed Concrete Bent Cap



Figure 2.2.9. Last girder installed at the jobsite

2.2.4 Challenges

Potential material shortage of steel plate stock is a challenge for accelerated construction. Caltrans engineers realized that rebuilding quickly would hinge on the availability of materials and securing the right contractors.

Concrete deck pours also presented a slight challenge. The concrete was designated by compressive strength and required a 96-hour compressive strength of 3600 psi prior to directly supporting construction loads. Designating concrete by compressive strength turned on a few switches from Section 90 of the Standard Specifications, such as a cementitious material content requirement of 675 lbs. min and 800 lbs. max per cubic yard. Also, all of the compressive strength requirements from Section 90 were revised to apply to the 96-hour limit instead of a 28-day limit. One restriction was that proprietary rapid strength concrete was not allowed (currently only allowed on paving and approach slabs for Caltrans). After the addendum stage, Caltrans permitted the Contractor a couple of mix design options. The one he chose essentially eliminated the Caltrans requirement for supplementary cementitious material and added a shrinkage-reducing admixture (SRA), which was not on the list of pre-approved admixtures.

The addition of SRA to the mix made it difficult to evaluate the other methods of concrete construction. It is unknown whether cracking would have been better or worse without the SRA, with permanent steel deck forms, with a lower compressive strength, or with a longer cure time.

2.2.5 Lessons Learned

The following factors contributed to the success of the project:

- A. Scope of the work was clearly identified by Structure Design, METS, and Structure Maintenance and Investigations;
- B. Accelerated PS&E process;
 - i. A attainable deadline times were set for structure draft PS&E and final PS&E packages, and addendum requests, and
 - ii. Key personnel were identified in District OE and DES-OE to process the documents.
- C. Pre-designated options were allowed rather than the use of an alternative or a CRIP;
 - i. The Contractor chose the precast, prestressed concrete cap option for Bent 19 over the structural steel bent cap. This decision proved essential in expediting the construction operations.
- D. Streamlined addendum request process;
 - i. SOE sent addendum requests to both District and DES-OE.
 - ii. Structure's addendum requests were quickly approved by the District.
 - Structure Design worked directly with a DES-OE detailer for plan changes. The formal addendum included plan changes in a format that could be faxed to the bidders.
 - SOE described other plan sheet changes in words.
- E. "Can-do" attitude, and innovative alternatives were utilized;

- F. The Department organization was revised for this effort into more of a horizontal alignment, rather than its typical vertical alignment, as lower level staff worked directly with upper levels of management towards the common goal;
- G. The unambiguous objective to get the reconstruction completed as soon as possible while maintaining quality helped focus staff on quick cooperative decision-making;
- H. Many large decisions (when to advertise, and award, procurement mechanisms, contract type) were made at the executive management level. This worked well for this relatively small emergency project and allowed executive management to weigh all issues when making these decisions;
- I. All staff understood that if a problem had the potential to delay the project, it was communicated to management and usually resolved in a few hours. Everyone was clear on what their duties were and completed their tasks as required.
- J. Communications with the Contractor, subcontractors and all Caltrans functional units was exceptional and led to quick response to all issues. The normal formal communications protocol was relaxed to the benefit of the project.
- K. The shop drawing review process and the Request for Information (RFI) process was expedited by delivery via email directly to all interested parties.
- L. Structure Design was well prepared with relevant software to expedite the design process.

The following lists some of the recommended improvements for future emergency

- A. Decision-making authority, oversight of decisions, communication protocols, and reporting relationships should be preplanned to manage the work effectively.
- B. Implementation of an Incident-Command System (ICS), similar to that used by most emergency responders, can provide a responsive management system that can be scaled up or down to suit the needs of the recovery effort. An ICS system should be established and drilled at least annually and possibility with other participating agencies.
- C. Conduct integrated multi-functional/multi-agency emergency response exercises. Create emergency response checklists and an emergency response binder to identify roles and responsibilities, control and decision-making hierarchy, contact information, contracting alternatives, information sharing, and media press releases.
- D. Document roles, responsibilities and the decision-making hierarchy. Some of the staff identified as decision makers did not necessarily exercise their authority. This caused some confusion, which was easily overcome on this small project, but may not be so easily on larger-scale projects.
- E. Emergency/on-call consultant and construction contracts are needed to expeditiously deliver A&E construction inspection resources to the field from conception to implementation.

2.3 I-5 Southbound Truck Route Undercrossing (Repair)

2.3.1 Project Background

The I-5 Southbound Truck Route Crossing repair in Los Angeles County is another successful application of ABC. The Truck Route, [Br. No. 53-1959], separates truck traffic from the mixed flow lanes on I-5 as it traverses a steep grade into the Los Angeles Basin. A chain-reaction accident involving thirty trucks and two passenger vehicles occurred on the morning of October 13, 2007 on the southbound Interstate 5 undercrossing tunnel. The tunnel truck route was immediately closed, forcing trucks to share the three-lane freeway with commuter traffic.

The tunnel is a 550-foot long, reinforced concrete box girder superstructure set on strutted abutments. It was built in 1975. The chain-reaction collision damaged a vital portion of the north-south artery just south of the intersection of I-5 (Golden State Freeway) and SR14 (Antelope Valley Freeway), and sparked a devastating inferno inside the tunnel. The estimated 1500°F temperature caused the exposed concrete on the abutment faces to crack exposing some main vertical reinforcing steel bars. In addition, superstructure soffit at the entrance region cracked and showed discoloration over large areas, a sign that its chemical properties may have changed. Immediately, Caltrans ordered temporary steel beams placed in the middle of the tunnel to support the concrete superstructure girders and stabilize the portion of the structure reopened to support I-5 traffic above.

METS inspectors took extensive core samples of concrete and steel for microscopic examination in order to evaluate the extent of the damage. Evaluations concluded that the tunnel entrance portion of the box girders required replacement, and that the abutment tunnel walls required rehabilitation.



Figure 2.3.1. Aerial Photo of the Site

2.3.2 Project Goals

Since the truck crossing serves as a vital commerce artery between Los Angeles and Central California, the District 7 and Caltrans Directors requested accelerated construction methods be employed to reopen the truck route crossing which is a vital economic facility. The I-5 southbound truck bypass connector that passes through the tunnel to northbound Highway 14 remained closed for an estimated two-month period.

2.3.3 ABC Implementation

Caltrans designed precast girders to replace the first 100-feet of the superstructure, shotcrete abutment wall repairs, and strutted abutment bolsters. Concrete for the new deck was restricted to meeting a 3600 psi at 96-hours (but not more than 4500 psi) specification requirement. The added dead load of stay-in-place metal deck forms was included in the design of the precast girders to facilitate expedited construction.

Precast girder manufacturing took about one week. Fifteen girders were erected in one day. Installation of steel forms, deck reinforcing steel, and placing the deck concrete took approximately two days working 24-hour shifts. The real time savings was in the fabricating of the precast girders. These girders were available on site within days of the construction work starting. In addition, Caltrans engineers fast-tracked the shop plan review process, cutting the typical review time from weeks to a matter of hours. The shop plan review process took only one day. The strategy resulted in reopening of the crossing within sixty days of the inferno, with much of the time expended in assessing the extent of the damage and developing repair strategies.

Table 2.3.1. Structure Type Data

Structure Type	Precast I-girder
Spans	Single-span 60 ft, total width= 92.45 ft
Structure Depth	4'-3" depth/span ratio = 0.043
Deck Type	CIP concrete with stay-in-place forms, thickness= 7.5in
Alignment	Tangent horizontal alignment
Deck	CIP concrete w/ 96-hour strength limit
Abutments	Existing strutted abutment
Bents	N/A
Foundation Type	N/A
Vertical Clearance	15.5 ft
Temporary Vertical Clearance	15.5 ft
Barriers	Type 736 modified
Slope Paving	N/A
Temp Range	-2°C to 44°C (28°F-112°F)
Utilities	N/A
Skew	None



Figure 2.3.2. Photo of Girder Placement



Figure 2.3.3. Photo of Stay-in-Place Metal Deck Form



Figure 2.3.4. Photo of Construction Completion

2.3.4 Challenges

There were several challenges encountered during the project delivery and construction process. First, engineers had to wait for the maintenance crew to clear the tunnel of truck wreckage before entering to inspect the damage. The wreckage clearing took several days and thus consumed valuable time for a speedy repair assessment. Second, the concrete assessment affected the time for project decisions. Initial testing by METS and SM&I did not conclusively determine if the existing box girders needed to be replaced. Detailed fire damage assessment was expected to take several additional weeks of evaluation. Caltrans engineers made a risk-based engineering decision to replace the box girders at the northern entrance in lieu of waiting for more refined laboratory analysis. The north entrance girders experienced the worst fire and heat damage. The subsequent contract plans were delivered on October 23, 2007; the final fire damage assessment report was published on November 8, 2007, twenty-one days after the event. The report reaffirmed the risk-based decisions for girder replacements.

2.3.5 Lessons Learned

The following lists some of the recommendations that would have improved the delivery of the project:

- A. Decision-making authority, oversight of decisions, communication protocols, and reporting relationships should be preplanned to manage this type of event.
- B. Implementation of an Incident-Command System (ICS), similar to that used by most emergency responders, can provide a responsive management system that can be scaled up or down to suit the needs of the recovery effort. An ICS system should be established and drilled at least annually and possibility with other participating agencies.
- C. Conduct integrated multi-functional/multi-agency emergency response exercises. There needs to be more coordination between SM&I, District Maintenance Design, Traffic Operations, and other functional units.
- D. Document roles, responsibilities and decision-making hierarchy. Initially, it was unclear who is the final decision maker (i.e. Structure Design, Project Manager, SM&I, or others). Some of the staff identified as decision makers did not necessarily exercise their authority. When preplanning and practicing a response effort, consideration should be given to the aptitudes of staff in key roles.
- E. Faster response from damage assessment teams. The fire damage assessment needs to be expedited to help engineers make sound repair strategy decisions. In this case, engineers had to make a risk-based decision before the release the damage assessment.

2.4 Russian River Bridge (Replace)

2.4.1 Project Background

The existing Russian River Bridge, [Br. No. 20-0038], was a steel pony truss bridge over the Russian River in Geyserville, Sonoma County, California. It was severely damaged during the series of storms in the last two weeks of December 2005. The bridge was closed to traffic causing a hardship to the local community. It was the shortest route to the high school on the other side of town and closure of the bridge resulted in a 40 minutes detour every school day.

2.4.2 Project Goals

Since the bridge serves as a vital link for the community of Geyserville as the only bridge over the Russian River in this part of Sonoma County, its closure created a hardship to the local community. It is the shortest route to the high school on the other side of town and closure of the bridge resulted in a 40 minutes detour every school day. The goal was to complete the bridge replacement in three months, finishing before the start of the school year at the end of August.

2.4.3 ABC Implementation

2.4.3a Design

During the type selection process, the designers dealt with the following restrictions:

- A. Environmental – no falsework in the channel;
- B. Tight schedule – eight months from closure of the bridge to opening to traffic;
- C. Better quality control – less demand on the field staff;
- D. Construction window – from May until August.

These restrictions led to a precast prestressed bridge type as the most suitable alternative. Four standard sections were examined during type selection: I-Girder, Bulb-T Girder, Spread Box Girder, and Adjacent Box Girder. The dictated depth to span ratio was much less than 0.045, a typical value for such a precast system.

All four contemplated alternatives were simple span girders made continuous with a cast-in-place composite deck. Every effort was made to produce a biddable design using State standard sections, and thus affording fair competition to all precast manufacturers. Non-standard sections would have required additional time to manufacture new forms or modify existing ones.

Standard I, and Bulb-T sections did not work due to limited superstructure depth requirements controlled by hydraulics considerations. Thus, non-standard sections were required. Spread Box sections required less than 2 ft distance between the girders, and the use of forms for deck placement in such short distance was unpractical, and thus this section was discarded. The Adjacent Box girder was the only standard section that met the design demand with a compact superstructure depth-to-span ratio. No forms were needed for deck placement, thereby facilitating expedited field operations. The standard precast prestressed AASHTO box girder 48-in wide and 39-in

deep, with a 6 in cast-in-place reinforced concrete deck, was chosen during the type selection process. The adjacent girders were transversely post-tensioned at 1/4 span locations, where 8-in thick intermediate diaphragms were installed. A total of 120 girders were used in the original design. Superstructure box girders were made continuous for live loads using cast-in-place diaphragms in between girders.

Superstructure precast box girders were supported on cast-in-place drop bent caps via 12x8x3 elastomeric bearing pads (2 per each box). The drop bent cap had a constant width of 6 ft, and a variable span depth with minimum dimension of 6 ft.

In order to accommodate such large seismic displacement, and provide integral seismic resistance of the bridge structure, the superstructure box girders were pinned to the drop bent caps using # 9 reinforcing rebar every 2 ft along the length of the bent cap. Shorter column shafts at Bents 2 and 10 were isolated from the surrounding soil for about 21 ft below the mud line to increase their free length and hence increase their ductility capacity. Finally, additional mild steel was added to the superstructure girders to resist one quarter of the dead load weight acting as vertical seismic acceleration².

By mid March, the biddable design package (Plans, Specifications and Estimates) was ready to list. Bids were based on the sum of the item totals for the work to be done, plus the product of the number of bid working days to complete the work and the cost per day shown on the engineer's estimate. This form of bid contract is designed to reward a general contractor with the least working days to complete the construction (A+B bidding).

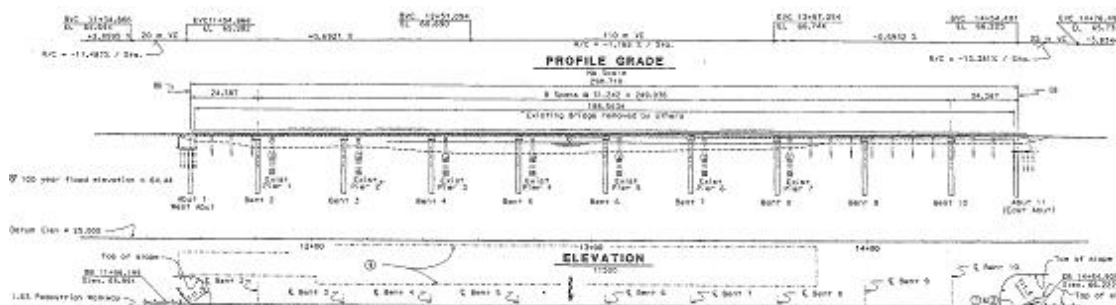

Figure 2.4.1. General Plan- Elevation

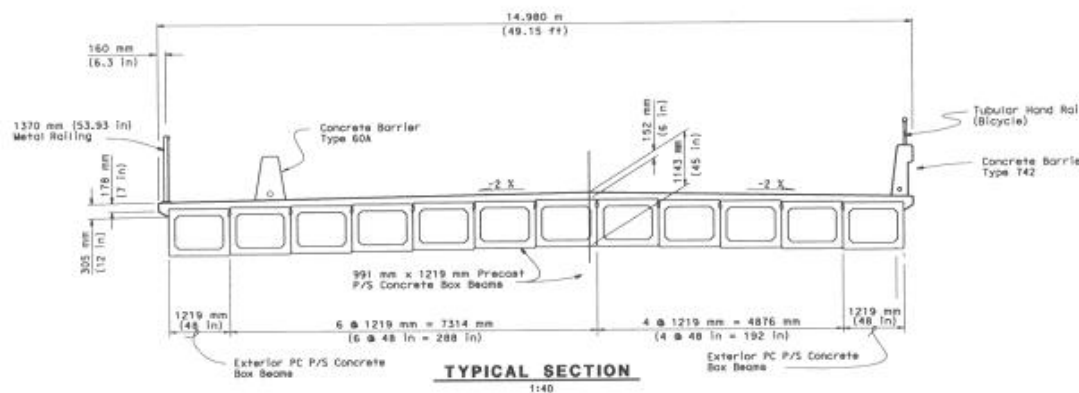

Figure 2.4.2. Typical Cross Section – Original Design.

2.4.3b Cost-Reduction-Incentive-Proposal (CRIP)

CC Meyers Inc, a general contractor was awarded the contract on April 11, 2006 with the lowest bid of \$14,383,026 dollars to build the bridge in 80 days. The general contractor, the sub consultant designer, and the precast manufacturer, proposed a Cost Reduction Incentive Proposal (CRIP) to use a non-standard Double T precast prestressed concrete girder with multiple stages of post-tensioning in the field. Caltrans immediately evaluated the proposal and approved the concept primarily to reduce construction time and possibly encumber significant cost savings. Closure of the nearest precast yard, coupled with the difficulty of transporting long girders on local roads, made this CRIP necessary.

Caltrans structural engineers cooperated with the Contractor's consultant designer to review and approve the design and detailing of the proposed alternative Double T girder in two weeks. Caltrans structural engineers performed an independent design check on the revised bridge design, including time dependant analysis during pre-tensioning, erection, first post-tensioning, deck pour, and second post-tensioning stages. This independent check also reviewed deflection assessment during pretensioning and post-tensioning, long-term camber, shortening in the longitudinal direction, and evaluated the movement rating for the joint assemblies.

The non-standard Double T girder was twice as wide as the original design (8 ft versus 4 ft), which resulted in half as many girders per span (total of 60 girders versus 120 girders) as compared to the original design. The standard Double-T section is typically suitable for 40 to 65 ft span lengths, and was not an option in the State approved girder sections for such long spans used for the replacement bridge.

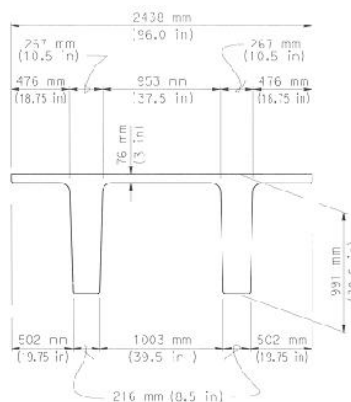

Figure 2.4.3. Typical Section- CRIP Non-Standard Double T Girder.

Table 2.4.1. Structure Type Data

Structure Type- Original	Precast box girders (multiple one-cell segments)
Structure Type- CRIP	Non-standard double-T precast girders
Spans	10-Spans: 8-spans @ 102 ft length, 2-spans @ 80 ft length total width= 49.15 ft
Structure Depth	3.75 ft depth/span ratio = 0.037
Alignment	Tangent horizontal alignment
Deck	6-in CIP concrete w/ transverse post-tensioned at 1/4 span
Abutments	Seat-type abutment
Bents	CIP drop bent cap w/ columns
Foundation Type	CIDH pile shaft w/ isolation casings
Vertical Clearance	N/A
Temporary Vertical Clearance	N/A
Barriers	Type 742 modified
Slope Paving	N/A
Temp Range	-2°C to 44°C (28°F-112°F)
Utilities	N/A
Skew	None

2.4.3c Construction

The alternative girder design used two-stage post-tensioning to maintain continuity of the superstructure under applied loads. Cast-in-place diaphragms between girders, and first stage post-tensioning, were used to create continuity under the weight of the 6-in deck slab. A second stage post-tensioning was applied to carry the bridge superimposed dead and live loads. Figure 2.5.4 depicts the sequence of the construction stages proposed in the alternative design. Superstructure depth was maintained in the proposed design. No changes were made to the substructure design as a consequence. Not only was the Double T section non-standard, but also the two stage post-tensioning employed was not a standard practice for precast girder design in California.

Construction started in early May 2006 with driving the new substructure cast-in-steel shell piles and building the drop bent caps. In the meantime, the Double T girders were fabricated in May/June, and erection was completed in July. Cast-in-place diaphragms and intermediate diaphragms were cast in early August, followed by the first stage post tensioning operation. The deck was poured and the second stage post tensioning took place three days later. Work around the clock resulted in the bridge opening to traffic on August 17, 2006.

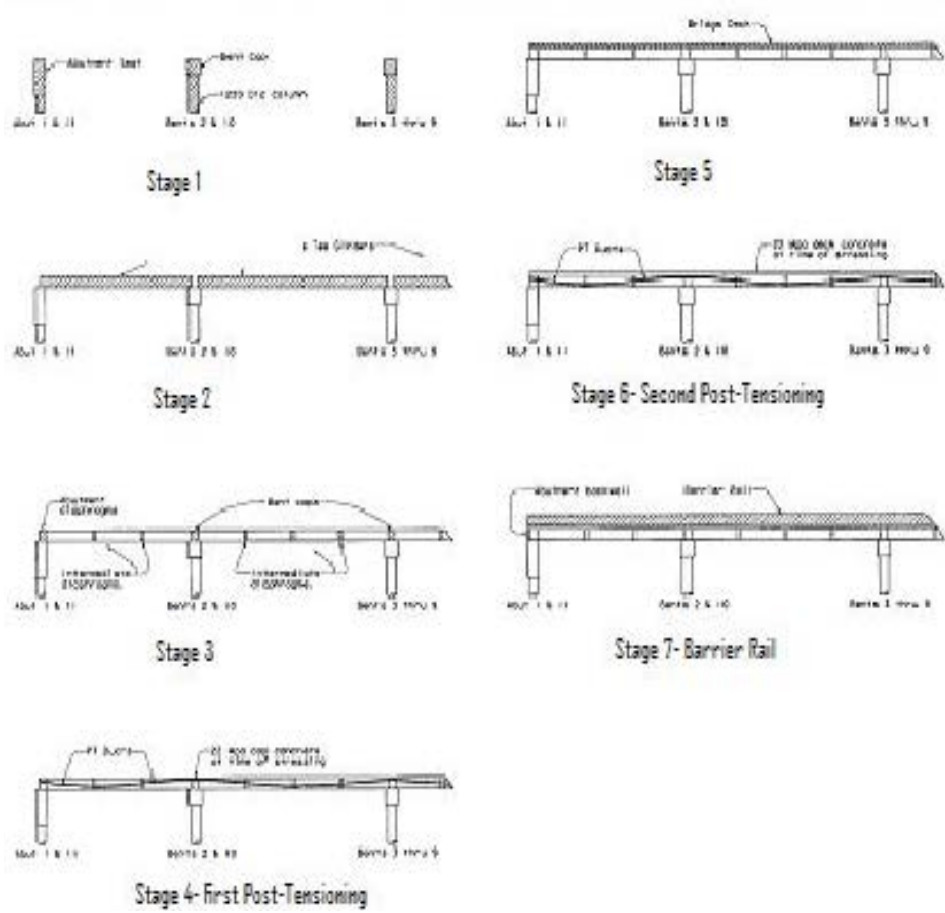

Figure 2.4.4. Sequence of Construction Sketch



Figure 2.4.5. (a) Construction Photos



Figure 2.4.5. (b) Construction Photos

2.4.4 Challenges

The emergency replacement of the Russian River bridge presented construction and design challenges. Calculations of elongations during jacking operation due to partial prestressing is one challenge. Another challenge is associated with designing such structure under construction stages with changing boundary conditions. The superstructure moment and stresses need to be evaluated when the structure was continuous during the non-composite stage (before and immediately after deck placement), and when composite (post-tensioned plus live loads). The stress assessment required extensive multi-stage structural analysis efforts that included using commercial finite-element software and spreadsheet bookkeeping combined with hand calculations.

2.4.5 Lessons Learned

The emergency replacement of the Russian River bridge presented many design challenges and the opportunity for creative solutions. Successful completion of this environmentally sensitive and accelerated construction drew the following lessons:

- A. Precast composite deck bridge type is a viable solution for accelerated projects in California. Cast-in-place box girder construction, while favored by most contractors in the State, has its limitations.
- B. Wider precast sections eliminated the deck falsework, and reduced number of precast girders. This in turn reduced the time and cost for fabrication, delivery and erection, and was a critical factor for the fast construction of this project.
- C. Multi-stage post-tensioning with precast sections may be an effective solution for bridges with compact span-to-depth ratio demands.
- D. Concern for potential project delays because of materials shortage (steel shells) led to the decision to use State furnished materials in the contract. This option is typically considered to be unwise as most contractors are adept in securing materials as fast and cheap as possible.
- E. Specifications on accelerated projects should allow for greater alternatives such as high early strength concrete and rapid set concrete.

- F. Finally, open and frequent exchange of ideas between design, construction and fabricator is essential for out of the box creative solutions. Effective communications and partnering are a key element to the success in such accelerated projects.

3. CASE STUDIES- PLANNED PROJECTS

3.1 San Francisco Yerba Buena Island Viaduct (Replace)

3.1.1 Project Background

The Yerba Buena Island Viaduct (YBI) [Br. No. 34-0066] carries Route 80 traffic across YBI Island and links the East Spans of the San Francisco Oakland Bay Bridge (SFOBB) with the YBI Tunnel. A 106-meter portion of the YBI Viaduct was in need of replacement (or significant retrofit and modification) to accommodate a detour structure required to allow traffic to bypass construction on YBI Island during the replacement of the East Spans of the SFOBB. The replacement structure was also needed to replace a section of the YBI Viaduct considered seismically deficient.

Numerous Advance Planning Studies for both retrofit and replacement of this section of the YBI Viaduct were completed. All required significant traffic delays (lane closures and short term bridge closures 8 hrs±) for at least nine to twelve months to complete the project. Construction was risky due to the close proximity of live traffic and tight schedules for closures. These all were deemed too risky and disruptive to implement.

Demo-Out-Move-In Strategy: The last APS looked at building a new structure next to the existing structure and then quickly demolishing the old structure and moving in the new structure. This required at least three full days of bridge closure. It was felt the public would be more accepting of a three-day closure than months of traffic delays. The other major advantage was that construction would take place away from live traffic reducing both risks to the traveling public, and risk to the construction timeline schedule.

3.1.2 Project Goals

The SFOBB is a major artery for the Bay Area residents. It is vital to minimize traffic delay. The project goal was to allow a complete bridge shutdown in three days for the viaduct replacement. Traffic Operations estimated that the economic impact was best minimized with the three-day shutdown compared to the conventional staged partial detours that would take more than one year. The mission was to select the days of the year that would experience the least traffic demand and thus inflict the least economic impact. Labor Day weekend 2007 was selected to be the target time for construction operations.

3.1.3 ABC Implementation

3.1.3a Design

A CIP/PS Box Girder with transverse girders and large edge beams spanning column supports was selected. The edge beams sit on bearing pads (placed on top of the columns) and are tied to the support columns with structural steel pins. This enabled the placement of the superstructure onto the support columns to be achieved with minimum complexity.

The construction sequence was developed with much input from the Contractor and the Bridge Moving Contractor. It was decided to move the bridge with “skid shoes” that ran on oiled steel tracks pushed with hydraulic rams. The bridge had to be designed to withstand the moving loads. The basic construction sequence was as follows:

- A. Prepare a level staging area adjacent to the existing structure for construction of the new superstructure. In this case, two large soil nail walls were needed to provide the level staging area for the sledding operation.
- B. Build the new support columns to the side of the existing Viaduct.
- C. Build the new superstructure, including temporary support columns, in the staging area.
- D. Place the moving equipment, including skid shoe rails and rail foundations.
- E. Close the SFOBB to traffic for up to three days.
- F. Demolish the existing structure.
- G. Move in the new structure.
- H. Set the new structure down on the support columns and place the column pins.
- I. Place the closure pour between the new and existing viaduct.
- J. Open the SFOBB to traffic.

Table 3.1.1. Structure Type Data

Structure Type	CIP/PS box girder with transverse girders and large edge beams
Spans	6-Spans: 18.83 ft to 75.62 ft longitudinal, total width= 93.8ft transverse
Structure Depth	6.0 ft longitudinal, 4.0 ft transverse, depth/span ratio = 0.08, 0.043
Alignment	Tangent horizontal alignment
Abutments	N/A
Bents	CIP/PS beam on rectangular concrete columns
Foundation Type	CIDH pile shaft
Vertical Clearance	15.5 ft min
Temporary Vertical Clearance	15.5 ft min
Barriers	Type 732 modified
Slope Paving	N/A
Temp Range	-2°C to 44°C (28°F-112°F)
Utilities	N/A
Skew	None

3.1.3b Construction

The staging area required level ground for the skid shoes to perform adequately. New temporary concrete columns were built in the staging area that mimicked the location of the new columns. This was done to minimize differential settlement at support

locations during construction. This proved to be expensive since the temporary columns were almost as expensive as the permanent columns.

The CIP/PS Box Girder was built on falsework, and then post tensioned. The falsework was then removed and the moving equipment was installed between the temporary columns. A test lift was performed; this proved to be an essential step as the Bridge Moving Contractor under-estimated the weight of the structure. Corrections were made to the setup to facilitate a smooth lift once the actual move commenced.

3.1.3c Roll-in Operation

The SFOBB was closed to traffic at about 10pm on Friday night. Since there was no room to roll out the existing superstructure span, the Contractor chose to demolish structure on-site within two days. The Contractor saw cut the existing floor beams (23m long each) and hauled them to a dumpsite in Oakland. The substructure was demolished using demolition hammers. The new span was lifted and moved in to place over a two-hour period. The clearance between the new and existing structure was 75 mm on each end. The superstructure was set on its new columns, and the column pins were installed. The column pins were dropped through prefabricated holes in the edge beam into prefabricated holes in the columns. The successful installation of the column pins was a testament to the tight tolerances the contractor was able to achieve during construction and moving. The entire operation took place over Labor Day Weekend 2007, and the Bay Bridge was open to traffic on Monday at about 3pm, fourteen hours ahead of schedule.



Figure 3.1.1. Photo of Bridge Demolition



Figure 3.1.2. Photo of New Bridge Roll-in

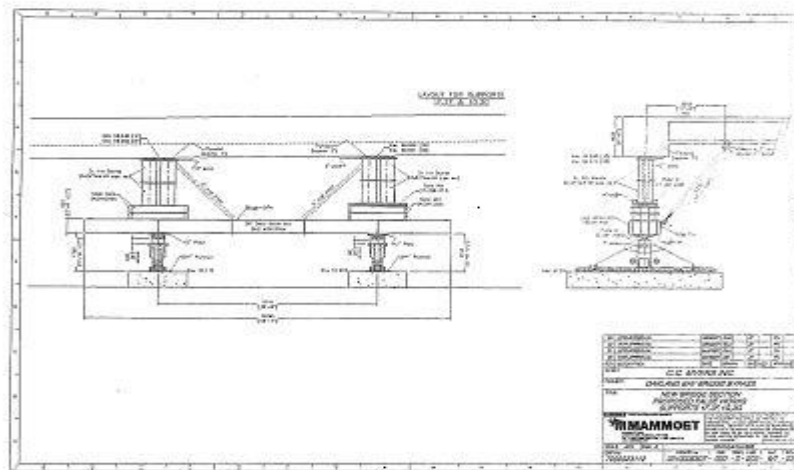

Figure 3.1.3. Skid Shoes Assembly Details

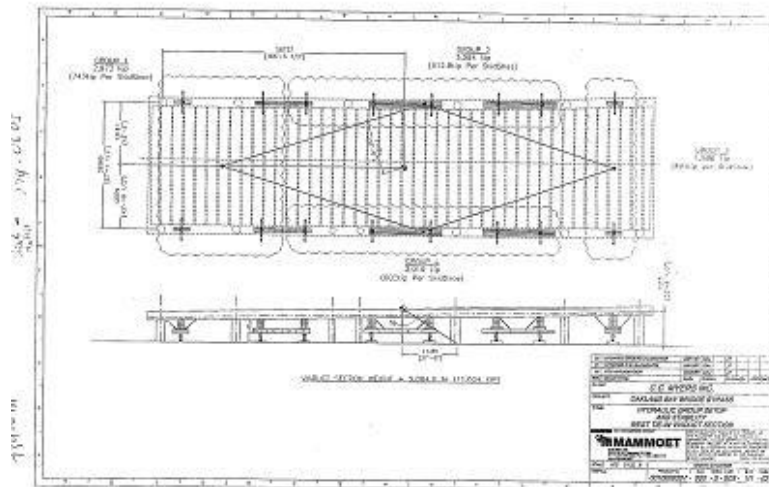

Figure 3.1.4. Skid Shoes Layout Details

3.1.4 Challenges

The Demo-Out-Move-In was an expensive option due to the following factors:

- A. A level staging area adjacent to the existing structure was required.
- B. It was necessary to eliminate differential falsework deflections. Support points had to maintain their relative elevations.
- C. Falsework had to be cleared out before moving equipment could be installed under the structure. Therefore, supports that mimic the permanent supports in both location and elevation are required in the staging area. These can be almost as expensive as the permanent support columns.
- D. The designer must work with the Heavy Lift Contractor and the Contractor during design so that the design can be tailored to the particular moving operation.
- E. The moving operation itself is very expensive.

3.1.5 Lessons Learned

The strategy yielded expensive construction. To accommodate the successful superstructure roll-in, the following factors need to be well coordinated:

- A. New columns need to be constructed to match the new deck grades adjacent to the site.
- B. Fitting pins into the new columns
- C. Fitting the new span in between the existing structure is a challenge.
- D. Fitting the pin into the columns is a potential challenge. Since prestress shortening is not well controlled.
- E. A test lift prior to the scheduled move is essential to avoid operational delays.

The structure must be built to extremely tight tolerances and thus required the following tasks:

- A. Relative elevations at support points on the superstructure must match the relative elevations at the respective top of the permanent columns. If not, permanent residual stresses will develop.
- B. The structure must fit into its ultimate position. In the case of the Bay Bridge example, the new superstructure had to slide into place between two existing frames. Surveys must be completed to verify existing vertical and horizontal geometry and assure the new structure will match.
- C. Support points on the superstructure must line up with tops of the permanent columns. In the case of the Bay Bridge example, prefabricated holes in the edge beam needed to line up with prefabricated holes in the column so that a steel pin could be installed linking the superstructure to the columns.
- D. The moving operation details must be thoroughly reviewed by the designer to assure stability during the move and to assure loads imposed on the structure by the moving equipment are acceptable.

3.2 Route 99/120 Separation Bridge (Replace)

3.2.1 Project Background

This project was located in the City of Manteca, approximately 60 miles south of downtown Sacramento. The primary purpose of the project was to widen Route 120 from 5 to 8 lanes by replacing the right and left structures with a single, wider bridge. The bridge was designed by Quincy Engineering, Inc. and the contractor was RGW Construction, Inc. The precast girders were provided by Pomoroy Corporation.

The Route 99/120 Separation [Br. No. 29-0125] was 110' wide and consisted of two 105' long spans to replace the existing shorter 2-span cast-in-place concrete box bridge structure. The superstructure depth was 4'-5", amounting to a depth-to-span ratio of 0.042. The superstructure type was a precast prestressed concrete box girder with a cast-in-place bent cap, deck, and end diaphragms. These were longitudinally post-tensioned for continuity, and made integral with a cap-to-column connection. At Bent 2, there were six 3.28 ft diameter columns pinned at the bottom to new pile footings. The construction was staged to allow nearly continuous traffic along Hwy 99. The structure was designed under the LFD design criteria.

3.2.2 Project Goals

This unique bridge construction alternative was selected due to several constraints that made conventional bridge alternatives less economical and therefore less desirable. The primary constraint associated with this project was the severely limited vertical clearance available due to the existing profile grades. This constraint was complicated by the desire to maintain traffic on both Route 120 and Route 99 during bridge construction. This constraint precluded the use of conventional falsework.

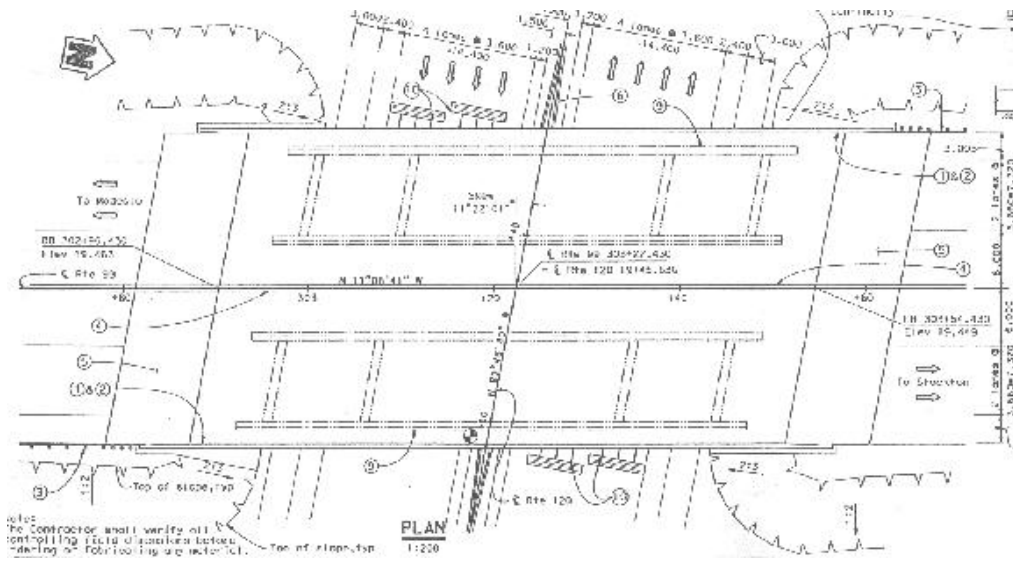

Figure 3.2.1. General Plan

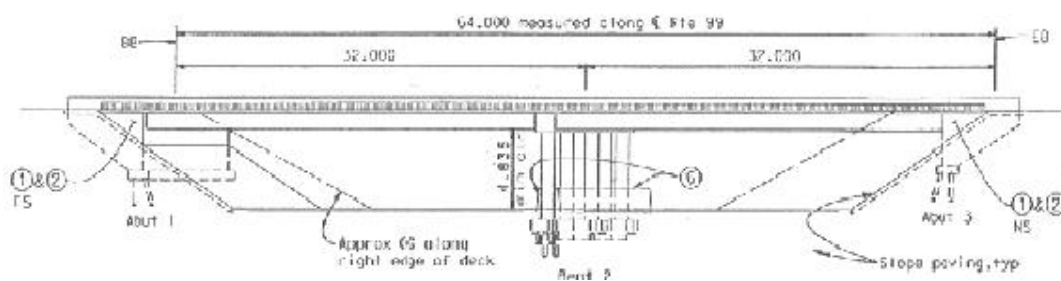

Figure 3.2.2. General Plan- Elevation

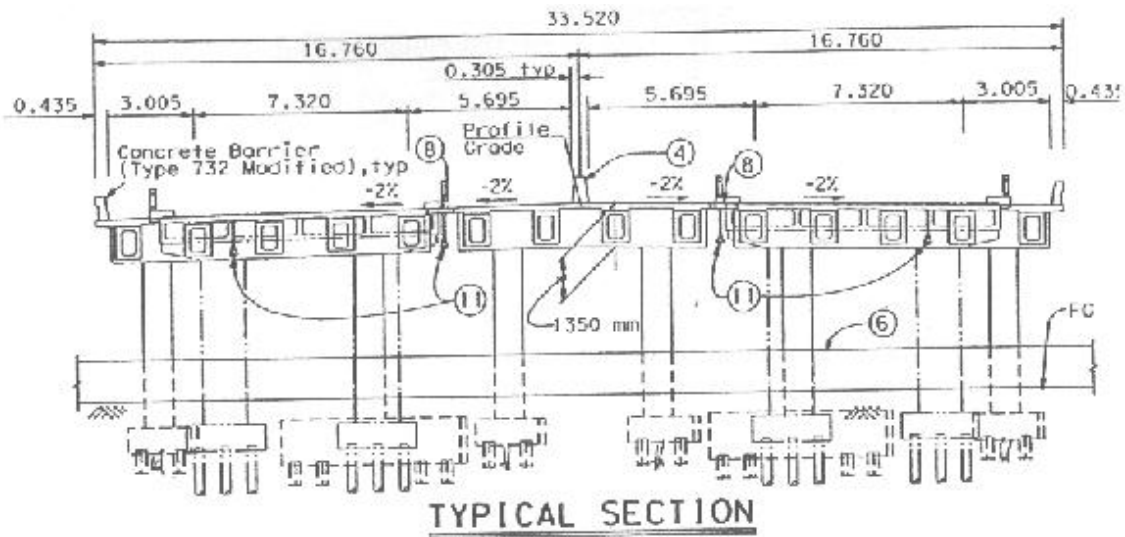

Figure 3.2.3. Typical Section

3.2.3 ABC Implementation

3.2.3a Design

The conventional CIP/PS box girder was initially considered since it was estimated to cost less to build. However, in order for the CIP/PS box girder with its requisite falsework requirements, while meeting the tight vertical constraints, Route 120 would either have to be reconstructed approximately 15” below the existing grade or the bridge would have to be constructed at a higher elevation, and then lowered into position. To complicate matters, the existing utilities along Route 120 would require relocation resulting in additional traffic handling challenges. Upon careful review, it was determined that reconstructing the roadway under such circumstances would have caused staging problems for other aspects of the project, including increased impacts to traffic flow.

The option of building the CIP/PS box girder high, and then lowering it into place was deemed impractical for three stages of construction. In addition, this option required the bottom of the columns to be fixed as opposed to pinned. Fixing the bottom of the columns required larger footings, which encroached into the much-needed lane width used to maintain traffic along Route 120.

The bulb-T girder alternative was considered as well. However, there are limited standard bulb T dimensions available in California. Of the conventional bulb-T girders, the minimum depth available is 4.6 ft, which is 12” too deep to satisfy the permanent overhead clearance for this project. Although shallow bulb-Ts may be special ordered, they were considered too costly of an alternative.

Due to extensive seismic design requirements in California, the spliced girder could not be selected until physical testing, research, and development of seismic design guidelines and seismic connection details were completed. A 50% scale model of a spliced girder bridge was designed and constructed at the University of California San Diego Structural Testing Lab. The model was comprised of a spliced girder superstructure with an integrated bent cap connected to a large diameter column. The unit was subjected to incremental displacement cycles, and after three displacement cycles, the column demonstrated a ductility of eight. Although there was severe plastic hinging at both top and bottom of the column and moderate joint shear cracking in the bent cap, there was minimal cracking in the girders. The successful performance of the superstructure was due, in part, to the torsion rigidity of the post-tensioned bent cap, which provided a mechanism to distribute forces fairly equally to all four spliced girders in the model. The test results validated California’s design methodology and details in keeping the superstructure “essentially elastic” during an extreme seismic event.

In addition, the recent NCHRP Research Project 12-57, which led to NCHRP Report 517, titled “Extending Span Ranges of Precast Prestressed Concrete Girders”, elevated the much-needed spliced girder design guidelines and examples to the national level. Subsequently, the AASHTO LRFD Bridge Design Specifications added provisions on “Spliced Girders”.

A custom sized precast box girder was finally selected because of its numerous advantages. There is a minimal forming effort for custom applications, and they are easily made from simple forming materials. Also, the girders are stable for transporting and erecting. Eight-inch webs can be employed to accommodate post-tensioning ducts. More importantly, casting the deck, bent, and diaphragms in place, and then post-

tensioning the integrated superstructure allows for depth-to-span ratios of less than 0.045. This results in the satisfaction of minimum vertical clearance, which alleviates a lot of traffic handling complications associated with lowering the existing grade.

Finally, the columns were pinned at the bottom to take advantage of smaller footing designs. The precast prestressed box girder with longitudinal post-tensioning alternative was ultimately chosen since it posed less congestion and cost less overall.

Table 3.2.1. Structural Type Data

Structure Type	Precast box girder w/ post-tensioning
Spans	2-Spans: 105 ft & 105 ft, total width= 110 ft
Structure Depth	4.43 ft, depth/span ratio = 0.042
Alignment	Tangent horizontal alignment, 11-degree Skew
Deck	CIP concrete
Abutments	Seat-type abutment
Bents	CIP integral cap, spliced with precast girders
Foundation Type	Pile footings
Vertical Clearance	15.86 ft
Temporary Vertical Clearance	15.86 ft
Barriers	Type 732 modified
Slope Paving	N/A
Temp Range	-2°C to 44°C (28°F-112°F)
Utilities	N/A

3.2.3b Construction

The following lists the sequence of stage construction:

- Step 1: The girder is cast at the precast plant while the substructures are constructed on-site.
- Step 2: Temporary supports erected.
- Step 3: The girders set in place.
- Step 4: Construct cast-in-place end diaphragms, bent cap, and intermediate diaphragms.
- Step 5: Allow CIP portions to reach min concrete strength of 4.0 ksi.
- Step 6: Place the deck concrete. The temporary supports remain in place as a redundant support system.
- Step 7: Post-tension the superstructure (675 kips/girder).
- Step 8: Remove temporary supports, and complete construction of the abutments.

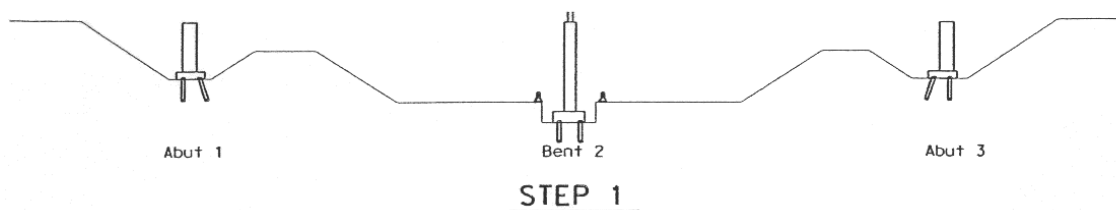

Figure 3.2.4. (a) Construction Sequence- Bent Placement

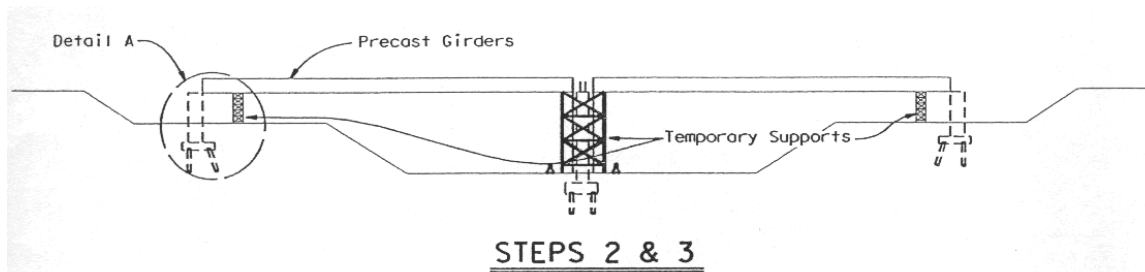

Figure 3.2.4. (b) Construction Sequence- Girder Placement

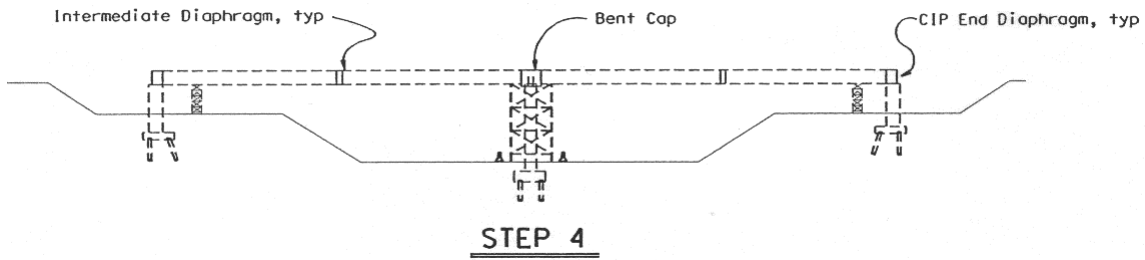

Figure 3.2.4. (c) Construction Sequence- Bent Cap Placement

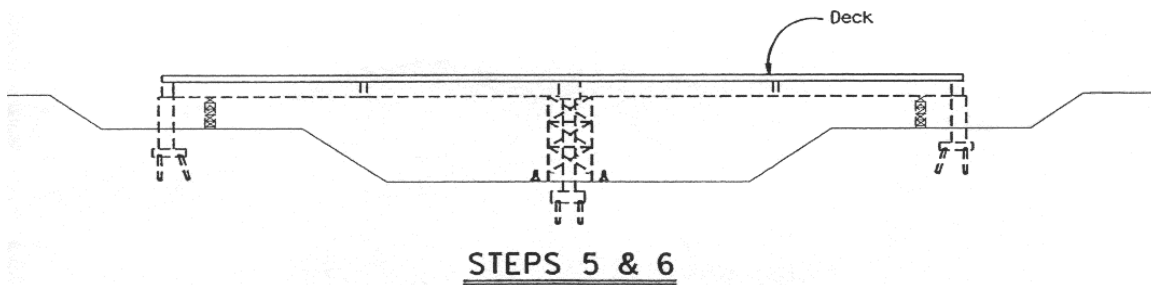

Figure 3.2.4. (d) Construction Sequence- Deck Placement

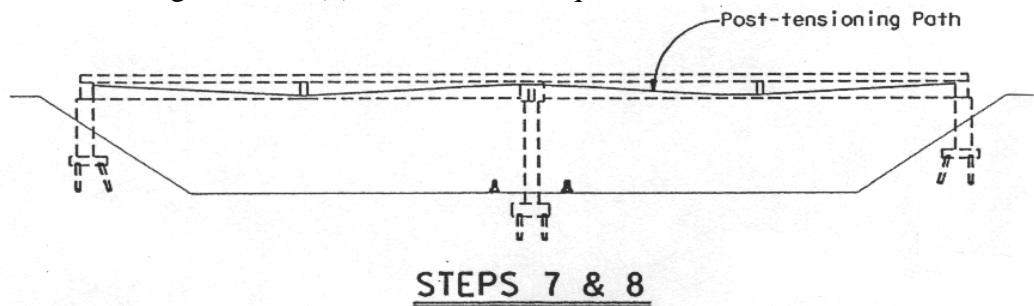

Figure 3.2.4. (e) Construction Sequence- Post-Tensioning

Table 3.2.2. Bridge Cost Data

Description	Superstructure	Substructure	Other
Total Cost	\$2,069,822	\$1,032,550	\$416,050
Deck Area	23,100	23,100	23,100
\$/sqft	\$89.60	\$44.70	\$18.01
Total \$/sqft	\$152.31		

3.2.4 Challenges

Designing this unique structure posed some challenges comparable to designing any such structure that undergoes construction stages with changing boundary conditions. It is a matter of bookkeeping loads and stresses. Short of utilizing commercial software that provides structural analysis as well as bookkeeping features, a spreadsheet is perhaps the most effective tool for recording and manipulating the data. This project required good spreadsheet skills combined with hand calculations for the simply supported PC/PS box girder analysis and a basic structure analysis tool for evaluating prestressing and live load forces for indeterminate structures. In this case, Caltrans Bridge Design Specifications (BDS) was used to evaluate superstructure moment and stresses when the structure was continuous during the non-composite stage (before and immediately after deck placement), and when composite (post-tensioned plus live loads). A spreadsheet was used for bookkeeping of loads and stresses between each stage of construction.

Another challenge associated with designing this unique structure was dealing with the negative moment over the bent cap during the cast-in-place deck pour. The construction stage occurred before post-tensioning and after the end diaphragms, bent cap, and intermediate diaphragms were cast.. Because this stage occurred when the superstructure was continuous, the negative moment originating from the deck pour must be accounted for over the bent cap. This challenge was resolved by extending the pre-tensioning strands into the bent cap, and adding bar reinforcing.

In California, moment reversal at the bent cap due to the cyclic nature of seismic loads has to be considered. It was found that the positive moment associated with seismic loads exceeded the superstructure's dead load moment. This condition was resolved by extending some of the bottom pre-tensioning strands into the bent cap.

As a final point, the designer had to consider that precast prestressed girders usually do not experience negative moment under service load. However, when the girders are made continuous over the bent, and then loaded with additional dead load and live load, the soffit of the superstructure experiences tremendous compressive stress near the bent caps. Even before the continuous structure is loaded, the soffit is under some compressive stresses induced by pre-tensioning. De-bonding some of the bottom strands alleviated this problem.

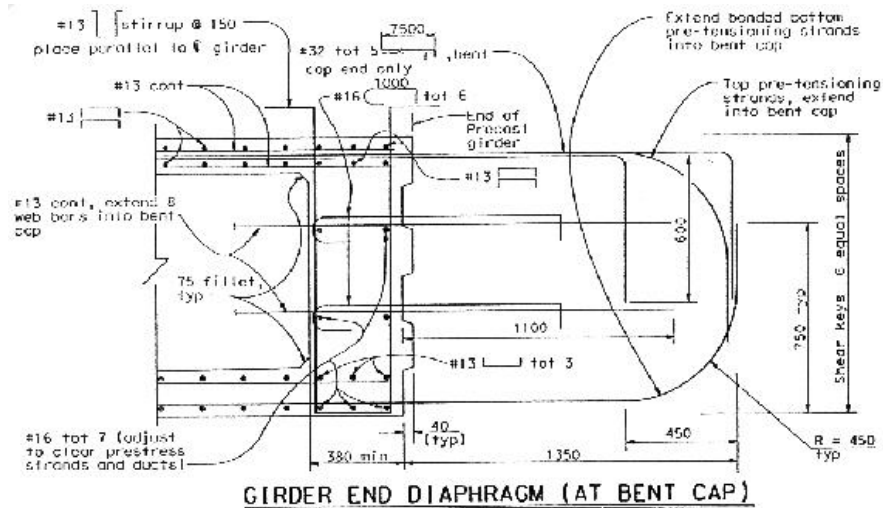

Figure 3.2.5. Girder End Diaphragm Details

Notes:

- Top Pre-tensioning:
Aps bonded = 395 mm²
- Bottom Pre-tensioning:
Aps bonded = 3155 mm²
Aps debonded = 1577 mm²
(4000 mm from bent cap end of precast girder)
Aps debonded = 788 mm²
(4000 mm from abutment end of precast girder)

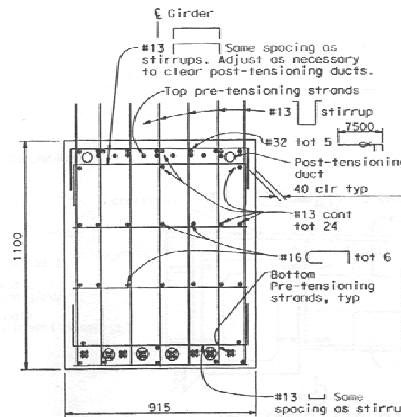

Figure 3.2.6. Girder End Section

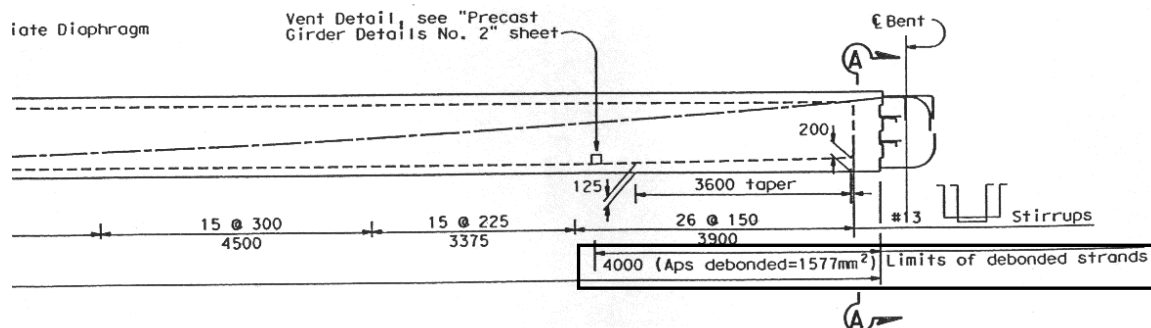

Figure 3.2.7. Precast Girder End- Elevation

3.2.5 Lessons Learned

It is often the case that detailing and fabricating a component for its intended design is even more challenging than the design process. As revealed earlier, flexural capacity of the superstructure through the bent cap was required to satisfy service loads and seismic loads. One can devise a certain amount of bar reinforcing to satisfy the numerical demands, but the component must be constructible at a reasonable cost.

In order to provide adequate engagement for flexural reinforcement through the bent cap, the extended strands and #10 bars were bent at a 90° angle in the bent cap. In addition, the reinforcement had to be staggered in opposing girders so that they bypass one another within the bent cap. This was simply accomplished by slightly offsetting the reinforcement from the centerline of the girder.

3.3 Hilltop Drive Overcrossing (Widen)

3.3.1 Project Background

The Hilltop Drive Overcrossing [Br. No. 06-0106] project was located in the City of Redding, just east of the Interstate 5/State Route 44 Interchange. It involved the widening of Hilltop Drive over State Route 44 from four lanes to six lanes (five travel lanes and a turn lane). The existing structure was a two-span cast-in-place prestressed concrete box girder bridge with span lengths of 95' and 88'. The superstructure depth was 3'-9". The bridge was widened from 61'-3" to 87'-6" to accommodate future traffic flows. The minimum vertical clearance over SR 44 is 15'-6", and both routes were expected to carry traffic for the duration of construction.

3.3.2 Project Goals

Like the 99/120 Separation, a unique bridge construction alternative was selected due to several constraints that rendered conventional bridge alternatives less economical, and therefore less desirable. First, and foremost, the available vertical clearance was a minimal 15'-6". In addition, matching the existing grade required a depth-to-span ratio of .039, which all but eliminated most economical and conventional solutions.

3.3.3 ABC Implementation

A custom-sized precast box girder was finally selected because of its numerous advantages. There is a minimal forming effort for custom applications of box girder sections, and they are easily made from simple forming materials. Also, the girders are stable for transporting and erecting, eliminating the need for special bracing during these operations. Eight-inch webs can be employed to accommodate post-tensioning ducts. More importantly, casting the deck, bent, and diaphragms in place, and then post-tensioning the integrated superstructure allows for depth-to-span ratios of less than 0.045. This results in the satisfaction of minimum vertical clearance, which alleviates a lot traffic handling complications associated with lowering the existing grade. Finally, the columns were pinned at the bottom to take advantage of smaller footing designs. The precast prestressed box girder incorporating a longitudinal post-tensioning

alternative was ultimately chosen since it posed less reinforcing steel congestion and proved the most economical.

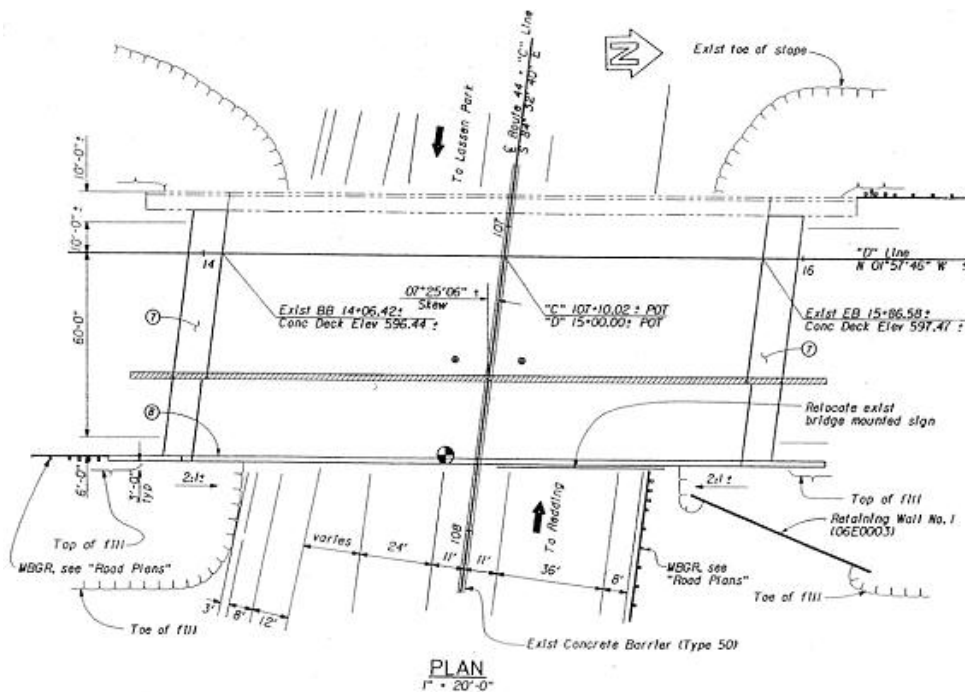

Figure 3.3.1. General Plan

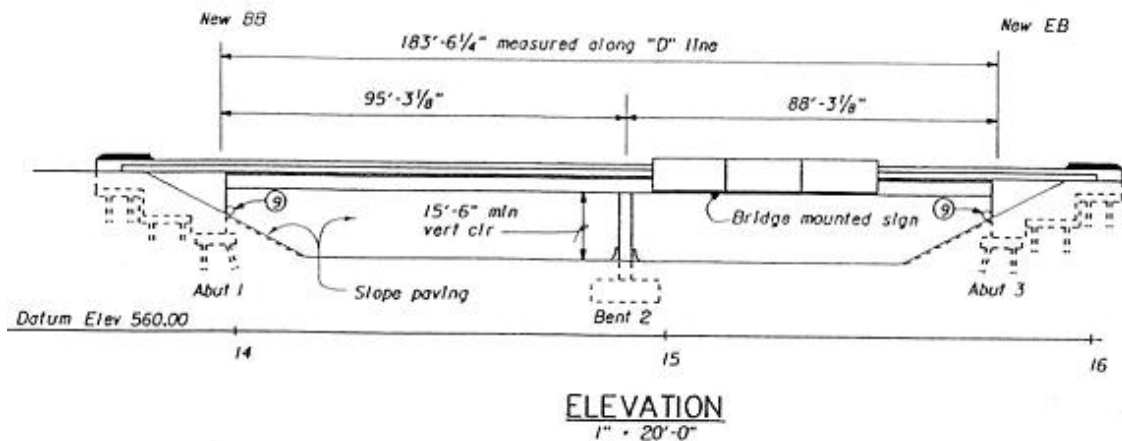

Figure 3.3.2. General Plan- Elevation

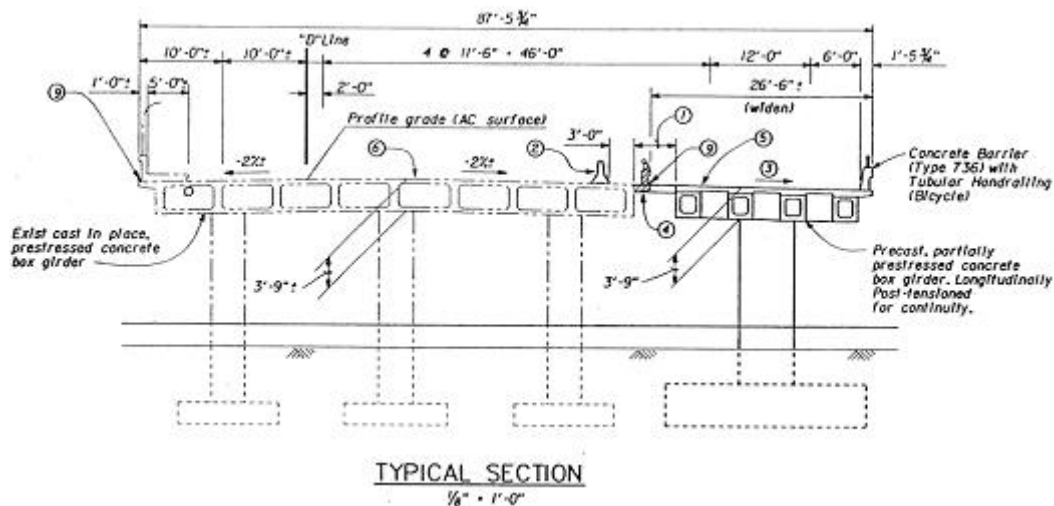

Figure 3.3.3. Typical Section

Table 3.3.1. Structure Type Data

Structure Type	Precast box girder
Spans	2-Spans: 95 ft- 3 in, & 88 ft- 3 in, total width= 87 ft
Structure Depth	3.75 ft depth/span ratio = 0.039
Alignment	Tangent horizontal alignment, 7-degree skew
Deck	CIP concrete
Abutments	Seat-type abutment
Bents	CIP integral cap w/ spliced precast girders
Foundation Type	Spread footing
Vertical Clearance	15.5 ft
Temporary Vertical Clearance	15.5 ft
Barriers	Type 736 Mod
Slope Paving	N/A
Temp Range	-2°C to 44°C (28°F-112°F)
Skews	7-degrees

The following lists the sequence of stage construction:

- Step 1: Girder is cast at the precasting plant while the abutments, bent footing, and column are constructed.
- Step 2: Erect precast girders on temporary supports.
- Step 3: Cast end diaphragms and intermediate diaphragms.
- Step 4: Cast deck in Span 1.
- Step 5: Starting at Abutment 3, construct deck in Span 2 and bent cap. Complete longitudinal post-tensioning 28 days after the last concrete has been placed. Then, remove temporary supports, and construct closure pour.

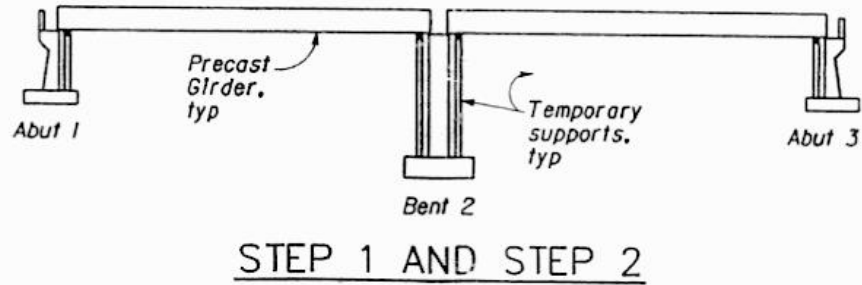

Figure 3.3.4(a) Construction Sequence- Girder Placement

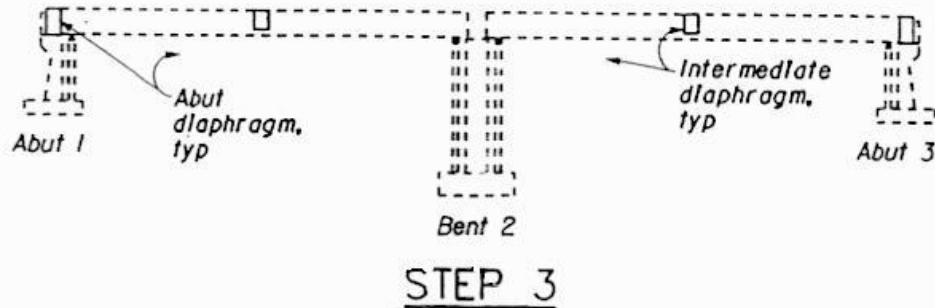

Figure 3.3.4(b) Construction Sequence- Diaphragm Placement

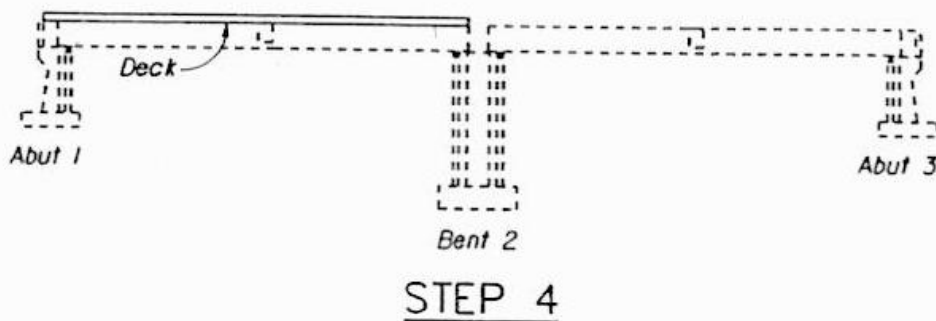

Figure 3.3.4(c) Construction Sequence- Span 1 Deck Placement

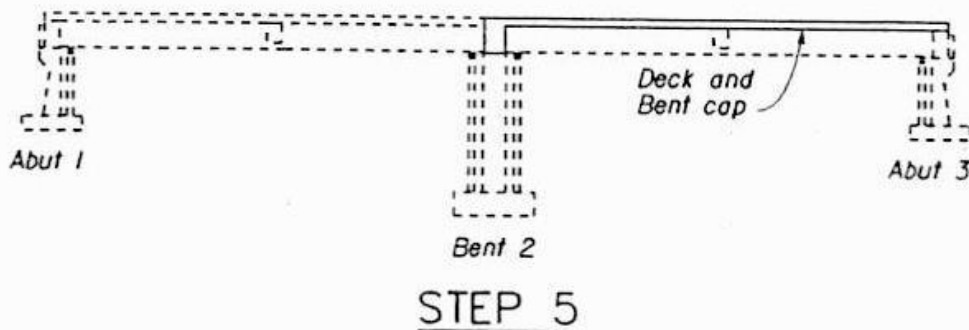

Figure 3.3.4(d) Construction Sequence- Bent Cap and Span 2 Deck Placement

The significant difference between the two case studies was that for the Hilltop Drive Overcrossing, the bent cap was cast after the deck concrete was placed. This variance in construction sequence allowed the rotation of the precast girder end to

occur during the deck construction. Then, the subsequent bent cap casting accommodated the rotation of the girder ends.

Table 3.3.2. Bridge Cost Data

Description	Superstructure	Substructure	Other
Total Cost	\$809,930	\$392,400	\$76,800
Deck Area	5,230	5,230	5,230
\$/sqft	\$154.87	\$75.03	\$14.69
 Total \$/sqft	 \$244.59		

3.3.4 Challenges

The main challenge is similar to that for the 99/120 Separation. The designer had to consider that precast prestressed girders usually do not experience negative moment under service load. However, when the girders are made continuous over the bent, and then loaded with additional dead load and live load, the soffit of the superstructure experiences tremendous compressive stress near the bent caps. De-bonding some of the bottom strands alleviated this problem.

3.3.5 Lessons Learned

The main advantages of the precast/prestressed concrete spliced girder bridge project can be summarized as follows:

- A. Rapid construction with the use of precast elements reduced congestion, traffic delays, and the total project cost.
- B. Longer span lengths reduce the number of piers, avoid obstacles on the ground such as roadways and utilities, improve safety if traffic is underneath, and avoid the placement of piers in waterways, thereby reducing environmental impacts.
- C. Eliminating superstructure joints improves structural performance (including seismic performance), reduces long-term maintenance costs, and increases service life.
- D. Minimizes bridge superstructure depth to obtain required vertical clearance for traffic or railway, through the use of post-tensioning continuous members.
- E. Minimizes falsework to improve the flow of traffic and improve safety for traffic and construction workers.

The advantages of utilizing precast/prestressed concrete spliced girder bridge types is quite evident when one considers the mitigation of impacts to other important aspects of a project such as rapidity of construction, reduction in congestion and traffic delays, longer span lengths, mitigation of environmental impacts, improvement of structural performance, and minimizing bridge superstructure depths.

4. TECHNICAL RESEARCH AND DEVELOPMENT

The lessons learned from the previous case studies yields technical issues that need further development and research. This section discusses recommended technical development and research to further improve ABC practice in California.

4.1 Technical Development

The following are suggested to conduct further technical development to improve accelerated bridge construction practice for future projects:

- A. Develop standards and guidelines for use of large incentives/disincentives and responsive bid requirements. Address bond requirements for bids with large incentives/disincentives.
- B. Segmented abutment design is the next logical step in developing precast abutments as a viable option for designers seeking competitive time saving solutions.
- C. Study and resolve high performance concrete issues; develop fast-curing specifications. Adding an upper limit on the compressive strength in the short time limit to control the rate of gain of strength and stiffness (e.g. 4200psi) has proven to be important.
- D. Conduct and periodically update a literature survey on current ABC technologies utilized by other states. Conduct feasibility studies on the applicability of these various ideas and technologies in seismic regions, such as California.

4.2 Technical Research

Demonstration projects in high seismic regions is one viable approach to test the constructability of specific proposed connection details, with short- and long-term monitoring established to quantify service-life performance. The following list technical research needs from the findings of the 2007 Seismic Accelerated Bridge Construction Workshop in San Diego [4].

- A. Post-earthquake accelerated column repair/replacement- Rapid repair of columns is the focus of this idea. Existing technologies such as steel casings and carbon fiber wrapping were considered as viable options, but more research was also suggested to develop new methods and associated specifications.
- B. Investigation of column seismic connections for ABC- Adequate connection between precast columns and superstructures is important so as to provide more viable options for designers. This includes new connection details and evaluating existing inverted bent cap to precast girder details.
- C. Response of segmental systems- More research is necessary to understand the seismic response of segmented structures. In general, a better understanding of jointed structure response is necessary – currently designed as emulative systems.
- D. Footing-to-Pile and Column-to-Foundation connections- More research is needed study seismic force transfer in precast column-to-CIP foundation connections.

5. CONCLUSION AND RECOMMENDATIONS

From the lessons learned from previous case studies, a series of recommendations were developed to improve delivery of future acceleration bridge construction projects. Accelerated bridge construction projects originate from either emergency response or non-emergency but with urgent capital improvement demands. Separate recommendations for each type of ABC projects are provided in the following sections. Finally, a selection guide is developed and provided listing the current available ABC practices in California, and its comparative feasibility to a specific project type.

5.1 Emergency Bridge Project Delivery

The following lists the recommended plan and implementation of accelerated bridge construction for future structures project delivery in emergency situations:

A. ABC-Delivery Team:

When the SM&I Emergency Response team has taken initial response actions and determined that major structure repair or replacement is needed [8], the Structure Design Office Chief (SDOC) will establish an ABC-Delivery Team to evaluate and work on project design and delivery. The ABC-Delivery Team consists of, but should not be limited to, the following:

- Key structure design engineers and detailers (including the Project Engineer)
- Subject matter experts and structural construction engineers
- GS and SOE

The SDOC serves as the lead to the team and will clearly defines the work goals and schedules to the team members. The members will collect and evaluate the structural type selection and solution alternatives and report them to the SDOC. The SDOC, along with the Executive Management Team, will decide if ABC methods are needed, and the major delivery schedule milestones.

B. Communication:

Implementation of an Incident-Command System (ICS), similar to that used by most emergency responders, can provide a responsive management system that can be scaled up or down to suit the needs of the project delivery effort. An ICS system should be established and drilled at least annually and possibility with other participating agencies. An ICS system should include not only direct project personnel but also the numerous support services needed (media, accounting, IT, procurement, contract services, etc.).

C. Executive Management Team (EMT):

Set up an EMT to be responsible for ABC project delivery decisions. The EMT will decide on when to advertise, and award, procurement mechanisms, contract type, and delivery schedules, etc. The EMT members will be Office Chiefs in the Districts and DES. The EMT will make decisions based on the ABC-Delivery Team's, District PDT, and other recommendations. The State Bridge Engineer, Chief Engineer, and/or the counterpart in the District may ratify the decision. Decision from EMT needs to be clear and must be made within a

short time frame so that the scope of work and objective is clearly identified and communicated to the staff.

D. Training

Develop and train key staff and engineers to attain and assign quick decision making skills needed to respond effectively to an emergency-recovery effort. When identifying and preparing key staff as decision makers, consideration should be given to the aptitudes of staff in key roles.

E. Accelerated PS&E process:

Set attainable deadlines for Structure draft PS&E and final PS&E packages, and addendum requests.

Identify key personnel in District OE and DES-OE to process the documents.

- Allowed pre-designated options rather than the use of an alternative or a CRIP (this must be explicitly addressed in the SSPs).

F. Streamlined addendum request process:

SOE forwards addendum requests to both District and DES-OE.

Structure's addendum requests should be quickly approved by the District.

Structure Design should work directly with a DES-OE detailer for plan changes. The formal addendum should include plan changes in a format that could be faxed to bidders.

SOE should seek areas to describe plan sheet changes in words to expedite the process.

- Emergency/On-Call consultants:
- Establish an on-call A&E contracts. Also need to have an on-call construction contracts, or the ability to bring consultant staff on board quickly to respond to emergency work.

G. Incentives and Bonds:

- Need to address and develop procedures and criteria for the use of large incentives/disincentives and responsive bid requirements. Address bond requirements for bids with large incentives/disincentives.
- Determine project costs and weigh options, including ABC techniques, against public delay costs.
- Reflect Delay/Time Costs in Bid Process for A+B.

H. Expedite Construction Administration:

- Shop drawing review process should be expedited by delivery via email directly to all interested parties.
- RFI process should be expedited by delivery via email directly to all interested parties.

I. Lessons Learned Team:

Create a post-event investigation team similar to the PEQIT (Post-Earthquake Investigation Team) to document lessons learned for non-seismic multi-hazard disasters. The team should consist of subject matter experts in structural analysis, loads, reinforced concrete, prestressed concrete, structural steel, maintenance, geotechnical, materials, and other relevant fields.

J. 'As-built' plans and shop drawings:

Some 'as-built' plans in BIRIS are of poor quality due to the quality of the image scanned. Additionally, some details are not available in the database system. Assign key staff to coordinate with Headquarters on obtaining Microfilms of the 'as-builts', if available. Request Headquarters Microfilm staff recreate or find the master index on which rolls the shop plans by bridge number are actually located.

K. Information Technology Support:

There is a need for training on how to share large files. Also, IT and purchasing support are needed to rapidly meet project demands. With an increasing amount of information provided electronically, the ability to access this information at the project level, in a timely manner, is critical. Wireless mobile broadband cards for laptop computers should be considered. IT personnel should set up a shared USB bus system so that all computers can be attached to the printers. Wireless air cards should be on hand for laptop wireless service.

L. Office Support:

Pre-programmed Emergency Access Cards for designated Managers and Supervisors should be on hand to access buildings during emergency situations. Also, reserve office supplies and resources should be prepared and be readily available in case of emergencies.

M. Work Breakdown/Timesheets:

Establish an EA and special designation code in TOPPS (similar to the 910076 code) for emergency jobs, so that the numerous WBS code breakdown would not be required.

5.2 Non-emergency ABC Projects

The previous case studies have exhibited the success and benefits of ABC. The ideals, methods and techniques of ABC combine to reduce traffic delays and hazards, while providing infrastructure improvement at a fast pace. The results yield benefits to the traveling public and the regional economy. In California, where the standard practice does not specifically accelerate construction, ABC does require special construction practice that typically demands a premium with respect to construction costs. Typically ABC project examples are not as efficient as conventional "day" shift construction. ABC project delivery costs are expected to be 30% - 100% higher than conventional construction costs.

Using ABC methods can portend great economical benefits that potentially offset the construction cost premiums. Conventional bridge construction typically induces traffic delays and congestion for an extended time period (average of 9 to 15

months). Thus, the long-term goal is to implement ABC as a standard bridge project delivery process for Caltrans and California. It is recommended that Caltrans initiate a practice development and implementation task force to develop a strategic work plan that provides standards, guidelines, and key policies for implementing structure design for accelerated bridge construction of future projects. The task force would consist of subject matter experts from design, construction, research, maintenance, materials, and other relevant fields. The members will develop much needed research and guidelines, implementation work plans, and promote future ABC practice in California.

In addition, it is recommended to initiate a study to determine costs of project delays due to construction operations. This study would include:

- A. Public delay costs
- B. Direct project costs
- C. Escalation of funding costs

Results of the study would help quantify the economic savings from using ABC, and thus provide convincing evidence to promote ABC in projects. Guidelines for application of offsetting delay costs to project direct costs should be established as a key outcome of this effort to ensure uniform, acceptable usage. FHWA review and acceptance of such guidelines is likely necessary prior to deployment on federally funded projects. Some work has been done in this area and is available on the FHWA website [9]; thus, this task may be as simple as validating that which experts for FHWA have already completed.

5.3 Accelerated Bridge Construction Technologies Guide- Current Practice

The following lists the current available practice in California to achieve accelerated bridge construction. The following tables provide a guide to select and evaluate feasibility of the available ABC technology to a specific project.

Table 5.3.1. ABC Solutions- Steel Girders

Structure Type	Structural steel rolled I- or built-up plate girders
Deck Type	CIP concrete or steel orthotropic deck
Common Span Range	60 to 300 feet
Depth/Span Ratio	0.04 to 0.045
Construction Type	Prefabricated in-shop and erected on-site
Applicability/Requirements	
<ul style="list-style-type: none"> ○ Place stock availability: High demands have reduced current stock availability ○ Transportation: Most stock are from out-of-state or out-of-country ○ Details: Welding of connections subject to fatigue ○ Corrosion: Best applicable in non-coastal environments 	
Advantages	
<ul style="list-style-type: none"> ○ Erection: Fast and ease of construction and placement ○ Lightweight: Reduced seismic forces yields savings on bent and foundation designs ○ Traffic impacts: No falsework is needed. May require a few hours of night-time closures to erect steel girders. Minimal traffic impact. ○ Public Costs: Minimal cost incurred on the public/regional economy 	
Disadvantages	
<ul style="list-style-type: none"> ○ Cost: Construction cost is typically higher than concrete structures ○ Maintenance: Require more detailed inspection and maintenance for fatigue and corrosion 	
Bridge Application Examples	
<ul style="list-style-type: none"> ○ Harbor Blvd Overcrossing (Br. No. 55-0859) ○ Baldwin Park Boulevard Overcrossing (Br. No. 53-3026) ○ San Francisco Central Viaduct (Br. No. 34-0077) 	

Table 5.3.2. ABC Solutions- Precast Girders and Slabs (Simple-Span)

Structure Type	Precast I, Bulb-T, T, and Box girders, & Precast slabs
Deck Type	CIP or precast concrete
Common Span Range	Slab 20 to 50 feet I-Girder 50-120 feet Bulb-T 90-145 feet Box 120-200 feet
Depth/Span Ratio	Slab- 0.03 I-section 0.055 Bulb-T 0.05 Box section 0.06
Construction Type	Precast off-site and erected on-site
Applicability/Requirements	
<ul style="list-style-type: none"> ○ Space: For large projects, large spaces are needed to store the precast segments. ○ Multi-span structure: Connection details need to accommodate seismic displacements. 	
Advantages	
<ul style="list-style-type: none"> ○ Repeatability: Girders can be cast quickly in the yard ○ Erection: Fast and ease of construction and placement ○ Traffic Impact: No falsework is needed. May require a few hours of night-time closures to erect steel girders. Minimal traffic impact. ○ Public Costs: Minimal cost incurred on the public/regional economy 	
Disadvantages	
<ul style="list-style-type: none"> ○ Cost: Construction cost is typically higher than CIP concrete structures; need repetition of spans for cost-savings ○ Transportation: Large and long girders require special transport permits along assigned routes, large capacity truck, and picking crane/rig. ○ Access required for crane; base preparation may be required 	
Bridge Application Examples	
<ul style="list-style-type: none"> ○ Truck Route Undercrossing (Br. No. 53-1959) ○ Mustang Wash Bridge (Br. No. 54-1274) ○ Bassett Overhead (Br. No. 53-0111) 	

Table 5.3.3. ABC Solutions- Precast Girders (Spliced-Span)

Structure Type	Precast I, Bulb-T, Double-T, and Box girders
Deck Type	CIP or precast concrete
Common Span Range	90- 220 feet
Depth/Span Ratio	I-section 0.05 Bulb-T 0.045 Box Section 0.045
Construction Type	Precast off-site and erected on-site, Spliced w/ post-tensioned on-site
Applicability/Requirements	
<ul style="list-style-type: none"> ○ Space: For large projects, large spaces are needed to store the precast segments. ○ Design and construction: special details and analysis needed for spliced connections and staged construction. 	
Advantages	
<ul style="list-style-type: none"> ○ Repeatability: Girders can be cast at a fast pace in the yard. ○ Erection: Fast and ease of construction and placement ○ Traffic Impact: No falsework is needed. May require few-hours night-time closure to erect girders. ○ Public Costs: Mild cost incurred on the public/regional economy 	
Disadvantages	
<ul style="list-style-type: none"> ○ Cost: Construction cost is typically higher than concrete structures ○ Traffic Impact: Temporary support required for splicing operation. Extended lane reduction required. ○ Construction: special attentions needed for spliced connection operations ○ Transportation: Large and long girders require special transport permit and routes, large capacity truck, and picking crane/rig. 	
Bridge Application Examples	
<ul style="list-style-type: none"> ○ Hilltop Drive Overcrossing (Br. No. 06-0106) ○ Route 99/120 Separation (Br. No. 29-0125) 	

Table 5.3.4. ABC Solutions- Precast Deck

Structure Type	N/A
Deck Type	Precast concrete
Common Span Range	90- 220 feet
Depth/Span Ratio	0.03
Construction Type	Precast off-site and erected on-site
Applicability/Requirements	
<ul style="list-style-type: none"> ○ Space: For large projects, large spaces are needed to store the precast segments. ○ Deck is supported on precast or steel girders. ○ Special attention needed to match cross-slope or grade of the deck 	
Advantages	
<ul style="list-style-type: none"> ○ Repeatability: Deck panels can be cast at a fast pace in the yard. ○ Erection: Fast and ease of construction and placement. Accelerated construction when combined with precast girders. ○ Traffic Impact: No falsework is needed. Minimal traffic impact. ○ Public Costs: Minimal cost incurred on the public/regional economy 	
Disadvantages	
<ul style="list-style-type: none"> ○ Cost: Construction cost is typically higher than CIP concrete deck ○ Construction: Tight construction tolerances can yield contractor claims ○ Difficult for skew, horizontal curved, or super-elevated geometries 	
Bridge Application Examples	
<ul style="list-style-type: none"> ○ Hayward-San Mateo Bridge (Br. No. 35-0054) 	

Table 5.3.5. ABC Solutions- Precast Segmental Box Girders

Structure Type	Precast box girders
Deck Type	N/A
Common Span Range	200- 440 feet
Depth/Span Ratio	0.03- 0.06
Construction Type	Precast off-site and erected on-site
Applicability/Requirements	
<ul style="list-style-type: none"> ○ Space: For large projects, require availability of large capacity casting yard. ○ Design: Need special analysis and design software ○ Suitable for sites that restrict/discourage falsework and temporary supports. ○ Suitable for super-long span with one to two lanes width structure. ○ Precast segments limited by weight 	
Advantages	
<ul style="list-style-type: none"> ○ Repeatability: Girders can be cast at a fast pace in the yard. ○ Erection: Fast and ease of construction and placement ○ Traffic Impact: No falsework is needed. Minimal traffic impact. ○ Public Costs: Minimal cost incurred on the public/regional economy 	
Disadvantages	
<ul style="list-style-type: none"> ○ Cost: Construction cost is much higher than concrete structures ○ Transportation: Large segments require special transport permit and routes, large capacity truck/boat, and picking crane/rig. ○ Large bent, columns/piers, and foundations required for construction staging loads ○ Long-term monitoring required to determine creep and loss effects 	
Bridge Application Examples	
<ul style="list-style-type: none"> ○ SFOBB East Span Skyway Structure (Br. No. 33-0025) 	

Table 5.3.6. ABC Solutions- Bridge Move-In

Structure Type	CIP/PS, Precast, and Steel structures
Common Span Range	Various
Construction Type	Precast or CIP off-site and roll-into place
Equipment Used	Skid-shoes track system, Self-Propelled Modular Transport (SPMT)
Requirements/Limitations	
<ul style="list-style-type: none"> ○ Space: A large level staging area adjacent to the site is required ○ Structure must be built to extremely tight tolerances ○ Differential Falsework Deflection must be eliminated. Support points need to maintain their relative elevations. ○ Falsework must be cleared out before moving equipment can be installed under the structure. Therefore supports that mimic the permanent supports in both location and elevation need to be constructed in the staging area. ○ The designer must work with the Heavy Lift Contractor and the Contractor during design so that the design can be tailored to the particular moving operation. 	
Advantages	
<ul style="list-style-type: none"> ○ Bridge replacement can be completed in hours. ○ Erection: Fast and ease of construction and placement ○ Traffic Impact: No falsework is needed. Require full road closure to move the structure in place. Minimal extended traffic impact. ○ Public Costs: Minimal cost incurred on the public/regional economy 	
Disadvantages	
<ul style="list-style-type: none"> ○ Cost: Roll-in operation cost is extremely higher than typical CIP and other ABC construction methodologies ○ Schedule: While the roll-in operation can be completed in days/hours, the preparation and construction of the new structure still require extended amount of time, thus not suitable for projects that require fast-track delivery. ○ Difficult for long-spans, skewed, horizontal curved, or super-elevated structures. 	
Bridge Application Examples	
<ul style="list-style-type: none"> ○ Yerba Buena Island Viaduct (Replace)- (Br. No. 34-0006) ○ Maritime Off-Ramp Grade Separation- (Br. No. 33-0623S) 	

Table 5.3.7. ABC Solutions Precast Abutment

Structure Type	Precast concrete abutment footing and stem
Spans	Various
Structure Depth	N/A
Requirements/Limitations	
<ul style="list-style-type: none"> ○ Space: For large projects, Girders can be cast at a fast pace in the yard. ○ Best uses for spread footing types: Pile connections not yet developed. 	
Advantages	
<ul style="list-style-type: none"> ○ Schedule: Abutment can be placed at a fast pace (within days). ○ Provide accelerated stage construction ○ Erection: Fast and ease of construction and placement ○ Traffic Impact: No falsework is needed. May require few-hours night-time closure to erect steel girders. Minimal traffic impact. ○ Public Costs: Minimal cost incurred on the public/regional economy 	
Disadvantages	
<ul style="list-style-type: none"> ○ Cost: Construction cost is typically higher than CIP concrete construction ○ Transportation: Large abutment pieces require special transport permit and routes, large capacity truck, and picking crane/rig. 	
Bridge Application Examples	
<ul style="list-style-type: none"> ○ Marble Wash Bridge- (Br. No. 54-1274) 	

REFERENCES:

- 1 <http://mobility.tamu.edu/ums/>
- 2 MTC State of the System 2006,
http://www.mtc.ca.gov/library/state_of_the_system/index.htm
- 3 <http://www.kron4.com/Global/story.asp?S=6538936>
- 4 Wolfe, R.W., (2007), “2007 FHWA Seismic Accelerated Bridge Construction Workshop Outcomes and Follow-up Activities,” *Final Report*.
- 5 Masroor, T., Ibrahim, A.M., Wang, L., Soin, P., (2007) “Russian River Bridge Replacement,” *Proceedings of the 2007 FHWA/PCI National Bridge Conference*, Phoenix, Arizona.
- 6 Nguyen-Tan, D., Pope, M., Ma, J., “Pre-tensioning and Post-tensioning Utilized in Harmony,” *Proceedings of the 2007 FHWA/PCI National Bridge Conference*, Phoenix, Arizona.
- 7 Franklin, A., Wahbeh, M., Speer, D., Pohl, M., (2007), “The Collapse and Reconstruction of the MacArthur Maze,” *Proceedings: Western Bridge Engineer’s Seminar*, Boise, Idaho.
- 8 Emergency Response Plan, Structural Maintenance and Investigations, Division of Maintenance, California Department of Transportation, 2006
- 9 <http://www.fhwa.dot.gov/bridge/prefab/framework.cfm>