

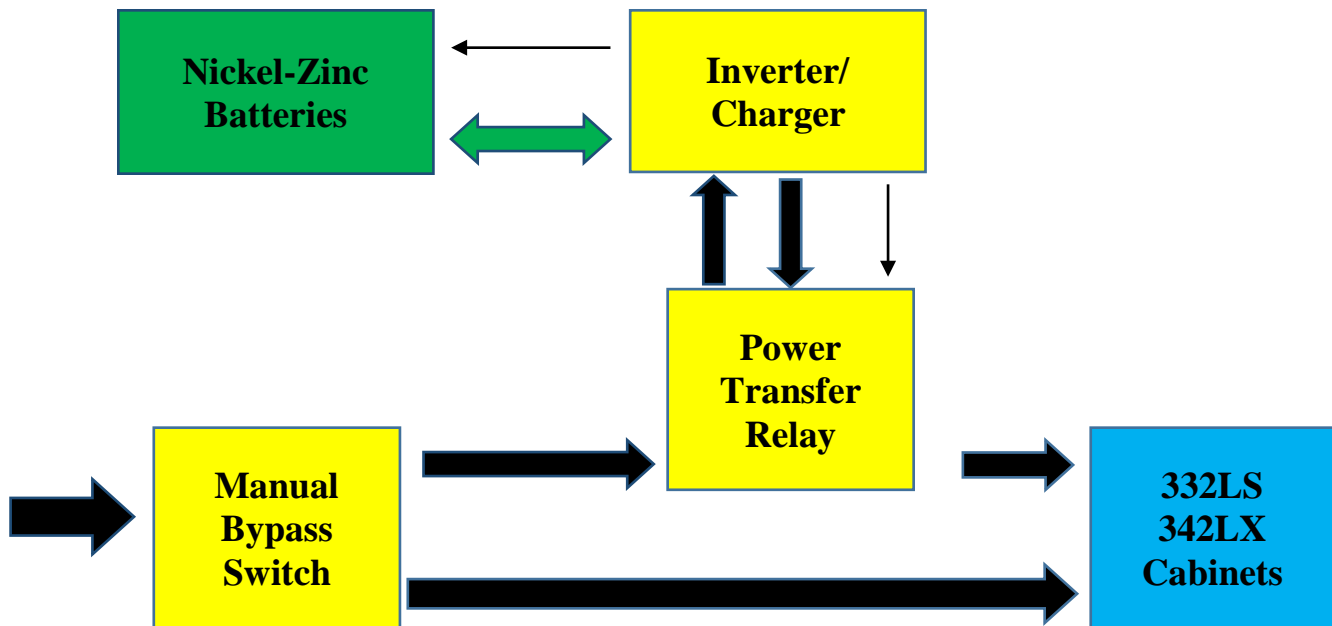

SPECIFICATIONS FOR **GREEN** TECHNOLOGY BATTERY BACK-UP SYSTEM

TEES CHAPTER 12



June 30, 2018

**STATE OF CALIFORNIA
DEPARTMENT OF TRANSPORTATION**



Edmund G. Brown Jr.
Governor

Brian P. Kelly
Secretary
Business, Transportation & Housing
Agency

Malcolm Dougherty
Director
Department of Transportation

Steve Takigawa
Deputy Director
Maintenance and Operations

Jasvinderjit S. Bhullar
Program Manager
Traffic Operations

Stan Slavin
Chief, Office of Technology

Herasmo Iñiguez
Branch Chief, Traffic Control Systems

TABLE OF CONTENTS

TEES	1
CHAPTER 12-SECTION A	7
GLOSSARY	7
CHAPTER 12-SECTION 1	8
GENERAL	8
12.1.1 Minimum Requirements	8
12.1.2 Battery Backup System Configuration	8
12.1.3 System Reliability	8
CHAPTER 12-SECTION 2	9
OPERATION	9
12.2.1 Compatibility	9
12.2.2 Run-Time	9
12.2.3 Output Capacity	9
12.2.4 Output Voltage	9
12.2.5 DC System Voltage	9
12.2.6 Transfer Time	9
12.2.7 Operating Temperature	9
12.2.8 AC Feedback	9
12.2.8.1 Feedback Level	9
12.2.9 Surge Protection	9
12.2.10 Power & Control Connections	10
12.2.11 AC Connection	10
12.2.12 DC Connection	10
12.2.13 Relay Connections	10
12.2.14 General Connections	10
12.2.15 Relay / Switch Ratings	10
12.2.16 Unit Failure	10
12.2.17 Overload	10
12.2.18 Bypass	10
CHAPTER 12-SECTION 3	11
INVERTER TECHNOLOGY, FUNCIONALITY, DISPLAYS AND CONTROLS	11
12.3.1 Intelligent two-staged GT-BBS	11
12.3.2 Two-Stage System	11

12.3.2.1 Intelligent Two-Stage, Stage One	11
12.3.2.2 Intelligent Two-Stage, Stage Two	11
12.3.2.3 User-Adjustable Parameters	11
12.3.2.4 Utility Power Restore	11
12.3.2.5 Line Quality Time	12
12.3.2.6 Low Restore	12
12.3.2.7 High Restore	12
12.3.3 Display	12
12.3.4 Physical Interface	12
12.3.5 Status LEDs	12
12.3.5.1 Green “Output” LED	12
12.3.5.2 Red “Fault” LED	13
12.3.5.3 Yellow “Alarm” LED	13
12.3.6 Event Log & Counters	13
12.3.7 Programmable Relay Contacts	13
12.3.7.1 On Battery Relay Contacts	13
12.3.7.2 Timer Relay Contacts	13
12.3.7.3 Low Battery Relay Contacts	13
12.3.7.4 Relay Contact Terminals	13
12.3.7.4.1 Terminal Type	13
12.3.7.4.2 Contacts	14
12.3.7.4.3 Labeling	14
12.3.8 Circuit Breakers	14
CHAPTER 12-SECTION 4	15
MOUNTING AND CONFIGURATION	15
12.4.1 EIA 19” Rack	15
12.4.2 Mounting Method and Space	15
12.4.3 GT-BBS Dimensions	15
12.4.4 Included Hardware	15
12.5.4.1 Bolt and Washer Requirements	15
12.5.4.2 Cable Ties and Cable Tie Holders	15
12.4.5 Interconnect Wiring	15
12.4.6 Relay Contact Wiring	15
12.4.7 Transfer Relay / Bypass Switch	16

12.4.8	Transfer Relay	16
CHAPTER 12-SECTION 5		17
COMMUNICATIONS		17
12.5.1	Serial and Network Communications Interface	17
12.5.2	User Configuration Menus	17
12.5.3	Network Configuration	17
CHAPTER 12 – SECTION 6		18
NICKEL-ZINC BATTERIES AND INTERFACE		18
12.6.1	Batteries and Battery Panels	18
12.6.1.1	Battery Type	18
12.6.1.2	Nickel-Zinc Battery Panel with Charging Units	18
12.6.1.3	Battery Charging	18
12.6.2	Inverter to Batteries Interface	18
12.6.2.1	Connectors and BBS Harness	18
12.6.2.2	Battery DC Power	18
12.6.2.3	Charging AC Power	19
12.6.2.4	5V Power Supply	19
12.6.2.5	Control Signals	19
CHAPTER 12-SECTION 7		20
WARRANTY		20
12.7.1	Terms and Conditions	20
CHAPTER 12-SECTION 8		21
QUALITY ASSURANCE		21
12.8.1	Quality Assurance	21
12.8.1.1	QA Process	21
12.8.1.2	QA Approval	21
12.8.2	Design Qualification Testing	21
12.8.2.1	Submittals	21
12.8.2.2	Test Data Submittal	21
12.8.2.3	Burn-In	21
12.8.2.4	Testing	22
12.8.3	Production Quality Control Testing	22
12.8.3.1	100-Hour Burn-In-Period	22
12.8.3.2	Visual Inspection	22

12.8.4	Caltrans Quality Assurance Testing	22
12.8.4.1	Sample Testing	23
12.8.4.2	Number of Units	23
CHAPTER 12-SECTION 9		24
GT-BBS DETAILS		24
12.9.1	GT-BBS System Block Diagram	24
12.9.2	GT-BBS Utility Power Connection Diagram	24
12.9.3	GT-BBS Relay Contact Terminal Block	24
12.9.4	GT-BBS Battery Interface	24
12.9.5	GT-BBS Harness	24

CHAPTER 12-SECTION A GLOSSARY

AC	Alternating Current
ANSI	American National Standards Institute
AWG	American Wire Gage
GT-BBS	Green Technology Battery Backup System
DC	Direct Current
IEEE	Institute of Electrical and Electronics Engineers
EIA	Electronic Industries Association
ITE	Institute of Transportation Engineers
KVA	Kilovolt-Ampere
LED	Light Emitting Diode
LCD	Liquid Chrystal Display
NEMA	National Electrical Manufacturers Association
NC	Normally Close
NO	Normally Open
OD	Outside Diameter
PTR	Power Transfer Relay
UL	Underwriters Laboratories
TB	Terminal Block
THD	Total Harmonic Distortion
UV	Ultraviolet Light
VDC	Volts DC
VA	Voltage Ampere
VAC	Voltage Alternating Current
NiZn	Nickel-Zinc
WH	Watt-Hour
BMS	Battery Management System
TLS	Transport Layer Security

CHAPTER 12-SECTION 1 GENERAL

12.1.1 Minimum Requirements

This specification establishes the minimum requirements for a complete emergency battery backup system for use with Light Emitting Diode (LED) Traffic Signal Modules.

The Green Technology Battery System shall be designed for outdoor applications in accordance with the Caltrans Transportation Electrical Equipment Specifications (TEES), dated March 12, 2009, Chapter 1 requirements.

12.1.2 Battery Backup System Configuration

The Green Technology Battery Backup System (GT-BBS) shall include, but not be limited to the following: Inverter/Charger, Power Transfer Relay, a separate manually operated non-electronic Bypass Switch (See A12-1 – GT-BBS Block Diagram) and all necessary hardware and interconnect wiring.

12.1.3 System Reliability

The GT-BBS shall provide reliable emergency power to a traffic signal system (Vehicle and Pedestrian Traffic) in the event of a power failure or interruption. The GT-BBS shall provide power for full run-time operation for an “LED-only” intersection (all colors: red, yellow, green and pedestrian heads) or flashing mode operation for an intersection using Red LED’s.

CHAPTER 12-SECTION 2 OPERATION

12.2.1 Compatibility

The GT-BBS shall be compatible with NEMA, Caltrans 332LX & 342X Cabinets, Model 2070 & 170 Controllers, and cabinet components for full time operation.

12.2.2 Run-Time

The GT-BBS shall provide a minimum two (2) hours of full run-time operation or 8 hours of flash operation for an “LED-only” intersection.

12.2.3 Output Capacity

The GT-BBS shall be able to provide a minimum of 800W @ +25°C, continuous active output capacity, with 90% minimum inverter efficiency while running in Backup Mode (on batteries).

12.2.4 Output Voltage

When operating in Backup mode, the GT-BBS output shall be 120 VAC \pm 5 VAC, sine wave output, \leq 3% THD, 60 Hz \pm 0.5 Hz.

12.2.5 DC System Voltage

The GT-BBS DC system voltage shall be nominal 48 VDC.

12.2.6 Transfer Time

The maximum transfer time allowed, from disruption of normal utility line voltage to stabilized Backup Mode line voltage, shall be no greater than 10 milliseconds. The same maximum allowable transfer time shall also apply when switching from Backup Mode line voltage back to utility line voltage.

12.2.7 Operating Temperature

The operating temperature for the inverter/charger, power transfer relay and manual bypass switch shall be -37 °C to $+74$ °C. Additionally, all components and parts used shall, at the very least, be rated for that temperature range.

12.2.8 AC Feedback

The GT-BBS shall be equipped to prevent a malfunction feedback to the cabinet or from feeding back to the utility service.

12.2.8.1 Feedback Level

In the event that the AC service feeding the GT-BBS is severed, or there is a utility black-out, the AC voltage measured at the AC inputs to the GT-BBS (Line to Neutral), shall be less than 1 VAC.

12.2.9 Surge Protection

The GT-BBS shall have lightning surge protection compliant with IEEE/ANSI C.62.41 and must be able to withstand 2000 volt surges applied 50 times across line and neutral. These surges shall not cause the GT-BBS to transfer to backup mode.

12.2.10 Power & Control Connections

The GT-BBS shall be easily installed, replaced, or removed by using easily removable cables for AC input, AC output, DC input, external transfer relay control and battery temperature sense.

12.2.11 AC Connection

The AC input and output shall be panel mounted plug / receptacles that allow no possibility of accidental exposure to dangerous voltages (male receptacle for AC Input and female receptacle for AC Output). The receptacles shall utilize some form of locking mechanism or hold down clamps to prevent any accidental disconnects.

12.2.12 DC Connection

The DC connection shall be a recessed one or two piece Anderson style receptacle or other 'quick connect' style device.

12.2.13 Relay Connections

The external power transfer relay control shall be heavy duty panel-mounted style connectors.

12.2.14 General Connections

All connections shall provide mechanically and electrically secure connections without the use of a screwdriver. The only exception will be the Programmable Relay Contacts, which shall require a small screwdriver for holding down the relay wires.

12.2.15 Relay / Switch Ratings

The Power Transfer Relay and Manual Bypass Switches shall be rated at 240VAC/20 Amps, minimum.

12.2.16 Unit Failure

In the event of inverter/charger failure, battery failure or complete battery discharge, the power transfer relay shall revert to the NC (and de-energized) state, where utility line power is connected to the cabinet.

12.2.17 Overload

The GT-BBS must be able to shut down in order to protect against internal damage in the event of an overload at the output.

12.2.18 Bypass

Placing the Manual Bypass Switch into "Bypass" shall route AC Utility power directly to the 332LS/342LX Cabinet. In this condition, if the inverter is then disabled and the batteries disconnected from the system, the Inverter/Charger unit shall be completely de-energized and shall be safe to remove from the intersection system, while still allowing the intersection to function normally.

CHAPTER 12-SECTION 3 INVERTER TECHNOLOGY, FUNCTIONALITY, DISPLAYS AND CONTROLS

12.3.1 Intelligent two-staged GT-BBS

The GT-BBS inverter technology shall be an Intelligent Two-Stage System.

12.3.2 Two-Stage System

12.3.2.1 Intelligent Two-Stage, Stage One

Stage One shall provide a minimum of 97% power efficient system that continuously conditions the utility power line and provides surge and transient suppression as well as noise filtering and harmonic attenuation to the cabinet.

12.3.2.2 Intelligent Two-Stage, Stage Two

Stage Two shall be a digital sine wave monitoring system. The incoming utility power shall be continuously monitored through an oscilloscope function to detect anomalies that cannot be addressed with stage one line conditioning. This system shall model the incoming sine wave in real time and detect sine wave abnormalities. User-adjustable sensitivity thresholds shall be available to assure downstream equipment is completely protected from sine wave deviation. When the digital sine wave monitoring system detects an abnormality that cannot be addressed with stage one line conditioning, the system shall transfer to Battery Backup mode and the triggering event with 1 sine cycle pre-event and 2 sine cycles post event shall be stored in the Event Log, along with a day/date time stamp. This transfer should be complete in 10 milliseconds or less.

12.3.2.3 User-Adjustable Parameters

The system shall transfer to Battery Backup mode at user defined, low and high cutoff voltage level transfer set points that are adjustable between 85 and 140 VAC (the default shall be 100 and 130 VAC).

The user shall be able to adjust the sensitivity level of the sine wave monitoring system. At a minimum, sensitivity levels shall be Low (low sensitivity – less sensitive to noise), Medium (normal GT-BBS sensitivity to sine wave deviations and noise), High (high sensitivity to sine wave deviations and noise). The system shall transfer to Battery Backup mode when the sine wave deviates from the programmed sensitivity level. This transfer should be complete in 10 milliseconds or less.

12.3.2.4 Utility Power Restore

When the utility line voltage has been restored within the user defined voltage thresholds or the deviation of the sine wave has been eliminated, the system shall transfer back to utility power after the Line Quality Time period has been completed. This transfer should be complete in 10 milliseconds or less.

12.3.2.5 Line Quality Time

The GT-BBS shall have a user adjustable line quality time. The minimum setting shall be 30 seconds and have the ability to increase in 15 second intervals defined by the user. The default value shall be 30 seconds. In the event that user adjustability is not available the minimum will Line Quality Time will be 3 seconds.

12.3.2.6 Low Restore

In cases of low utility line voltage (below the low voltage transfer set point), or absent utility line voltage, when the utility line voltage has been restored at or above $5 \text{ VAC} \pm 2 \text{ VAC}$ of the low transfer set point for more than 30 seconds (or the user configured line quality time), the GT-BBS shall transfer from Backup Mode to Utility Line Mode. The GT-BBS shall monitor the incoming utility line after the line voltage has been restored for up to 3 minutes. The incoming utility power shall be monitored by analyzing the sine wave and comparing the restored utility sine wave against the last stored utility sine wave before power failure. When the restored utility sine wave is stable, the system shall transfer back to utility power.

12.3.2.7 High Restore

In cases of high (above the high voltage transfer set point) utility line voltage, when the utility line voltage has been restored at or below $5 \text{ VAC} \pm 2 \text{ VAC}$ of the high transfer set point for more than 30 seconds (or the user configured line qualify time), the GT-BBS shall transfer from Backup Mode to Utility Line Mode. The GT-BBS shall monitor the incoming utility line after the line voltage has been restored for up to 3 minutes. The incoming utility power shall be monitored by analyzing the sine wave and comparing the restored utility sine wave against the last stored utility sine wave before power failure. When the restored utility sine wave is stable, the system shall transfer to utility power.

12.3.3 Display

The GT-BBS shall have a backlit LCD type display that is easily seen in both bright sunlight and in darkness. The screen shall be a minimum of a 4 line display the following information shall be displayed on a continuous basis; utility input voltage, cabinet load, percentage of battery charge, run-time in hours and minutes, GT-BBS status (On utility, On Backup), any alarms and faults, and relay status information.

12.3.4 Physical Interface

The GT-BBS shall use a well-defined keypad or dial that includes arrow, enter and escape/back keys so the user can efficiently navigate the menu system to make system programming changes and gather other status information.

12.3.5 Status LEDs

In addition to the LCD display, the GT-BBS shall include discrete status LED indicators. The purpose of the indicators is to draw the user's attention to the LCD.

12.3.5.1 Green "Output" LED

This optional LED will be ON any time that the output of the GT-BBS is modified, either by Backup Mode, or by Buck / Boost Modes

12.3.5.2 Red “Fault” LED

This LED will be ON any time that there are any faults in the system.

12.3.5.3 Yellow “Alarm” LED

This optional LED will be ON any time that there are any alarms in the system.

12.3.6 Event Log & Counters

The GT-BBS shall keep track of the number of times that the unit was in Backup and the total number of hours and minutes that the unit has operated in backup since last reset. This information shall be displayed through the LCD and shall be available for viewing via the exportable event log. For each event, the log shall contain as a minimum, a date/time stamp, duration, and what the type of event. The device shall log the data necessary to render a picture of the sine wave that caused the power fail event and make it available to the user for analysis.

12.3.7 Programmable Relay Contacts

The GT-BBS shall provide the user with between six (6) and eight (8) programmable dry relay contacts. These relay contacts shall be rated for a minimum of 1 amp @ 125 VAC. When any relay is energized, it shall show up on the LCD display. As a minimum, the programming options shall be, On Battery, Low Battery, Timer, Alarm, Fault, and Off.

12.3.7.1 On Battery Relay Contacts

The dry relay contacts that are configured for “On Battery” shall only energize when the Inverter is operating in Backup Mode.

12.3.7.2 Timer Relay Contacts

The GT-BBS shall have a timer that will energize the dry relay contacts (when configured for “Timer”) after the user configured time has elapsed. This timer is started when the GT-BBS in the Backup mode. The user can configure the timer from 0 to 480 minutes, in a minimum of 15 minute increments. The default setting will be 120 minutes.

12.3.7.3 Low Battery Relay Contacts

The GT-BBS shall have an adjustable low battery relay setting. This setting shall be adjustable so that the user can set the point at which the low battery relay energizes. This setting applies to any dry contact relay that is configured for “Low Battery”.

12.3.7.4 Relay Contact Terminals

The relay contacts shall be made available on the front panel of the GT-BBS via eight 3-position, screw hold-down, printed circuit board mounted terminal block. Additional terminals are allowed so long as they are adequately identified and labeled.

12.3.7.4.1 Terminal Type

The relay contact terminal blocks shall conform to On-Shore Technology, type ED2200/22, or Phoenix Contact type FRONT 2,5-H/SA 5, or WECO type 180-A-111, or equivalent. The spacing between each terminal shall be 0.197” (5 mm), with the hold-down screw and wire entrance both on the same face, facing forward and in the horizontal axis. See sheet A12-3 for additional information.

12.3.7.4.2 Contacts

Each relay shall have their own common and their own set of normally open (NO) and normally closed (NC) terminals. The terminals for each relay shall be oriented as NO- C-NC, on the terminal block.

12.3.7.4.3 Labeling

Each contact terminal block shall be labeled Relay 1 through 8. Additionally, each set of contacts shall be labeled with the NO-C-NC designation. Means to label each contact with function shall be provided.

12.3.8 Circuit Breakers

The GT-BBS shall be equipped with both Input and Output AC circuit breakers.

CHAPTER 12-SECTION 4 MOUNTING AND CONFIGURATION

12.4.1 EIA 19" Rack

All references made to EIA rail or EIA 19" rack shall conform to Electronic Industries Standards EIA-310-D, Racks, Panels, and Associated Equipment with 10-32 "Universal Spacing" threaded holes.

12.4.2 Mounting Method and Space

The GT-BBS shall be able to be shelf mounted or rack mounted on an EIA rail.

12.4.3 GT-BBS Dimensions

The entire GT-BBS, including the Inverter/Charger, Power Transfer Relay and Bypass Switch Assembly must be able to fit on the EIA rail and shelf in the dimensions specified above. Inverter/Charger dimensions shall be no be greater than 17.5" W x 10.25" D x 6.0" H and with EIA mounting brackets attached must be able to install on the EIA rails.

12.4.4 Included Hardware

The GTGT-BBS shall include all necessary mounting hardware. This shall include EIA mounting brackets, bolt and washers, cable ties, and adhesive backed panel-mount style cable tie holders.

12.5.4.1 Bolt and Washer Requirements

Bolts and washers shall meet the following requirements:

Screw Type: Pan Head Phillips machine screw

Size and Thread Pitch: 10-32

Material: 18-8 stainless steel (Type 316 stainless steel is acceptable as an alternate)

Washer: Use one flat washer (18-8 stainless steel) under the head of each 10-32 screw

12.5.4.2 Cable Ties and Cable Tie Holders

The amount and size of cable ties and the adhesive backed panel-mount style cable tie holders shall be adequate for the wire size of the particular GT-BBS and be of sufficient quantity to neatly dress the full length of provided wire inside of External GT-BBS Cabinet and/or 332A Cabinet.

12.4.5 Interconnect Wiring

All interconnect wiring shall be provided between Power Transfer Relay, Bypass Switch, and 3xxLX Cabinet Terminal Service Block. This wiring shall be no less than 9' of UL Style 1015 CSA TEW with the following characteristics:

AWG Rating: 10 AWG

Stranding: Rating: 105 strands of 30 AWG tinned copper 600 V, 105 °C, PVC Insulation

12.4.6 Relay Contact Wiring

Three (3) sets of relay contact wiring shall be provided. Each set shall be two twisted insulated conductors of UL Style 1015 CSA TEW 18 AWG wire, same ratings as above, except 16 strands of 30 AWG tinned copper.

12.4.7 Transfer Relay / Bypass Switch

The Power Transfer Relay and Bypass Switch Assemblies may either be discreet from one another, or they may be combined into one assembly.

12.4.8 Transfer Relay

There is also the option of the Power Transfer Relay being internal to the Inverter portion of the GT-BBS. The Bypass Switch will always remain a separate and discreet assembly.

CHAPTER 12-SECTION 5 COMMUNICATIONS

12.5.1 Serial and Network Communications Interface

The GT-BBS shall have Ethernet communication(s) interfaces for user configuration and management. The Ethernet Port shall be an RJ45, EIA 568B Pin Out connector.

The transport layer security protocol version 1.2 (TLS 1.2) shall be used to secure all communications over the Ethernet interface.

12.5.2 User Configuration Menus

All GT-BBS Configuration and System menus shall be accessible and programmable from the Ethernet port as listed in 12.5.3. Additionally, all log files shall be available through these ports.

12.5.3 Network Configuration

The GT-BBS shall support the following features: Provide TCP and UDP protocols over the IP protocol and support the HTTP and HTTPS application layer protocols. All TCP/IP communication over the RJ-45 Ethernet connection shall be encrypted and at a minimum adhere to the Transport Layer Security (TLS) 1.2 specification (<https://tools.ietf.org/html/rfc5246>). The GT-BBS shall support outbound messaging from the GT-BBS via SNMP, SMTP, HTTP, and HTTPS. Subnet masks for Class A, B, and C networks (See Table Below):

Network Host	BITS Class	Subnet Mask	Example IP Address
A	24	255.0.0.0	10.0.0.100
B	16	255.255.0.0	172.31.0.100
C	8	255.255.255.0	192.168.0.100

The GT-BBS shall be provided with Web-Based-Interface (WBI). The WBI shall allow the user to set Network Configuration Parameters and all system configurations using a Web Browser.

As a minimum, a user shall be able to do the following via the Web Browser:

1. View Logs
2. Change Modes of Operation
3. Configure Email Alarm
4. Adjust Line Quality Time Per. Section 12.3.2.5
5. Program Relay Contacts Per. Section 12.3.8
6. Configure Network Parameters

The GT-BBS shall have a default IP Address of 192.168.12.51, Subnet Mask as 255.255.255.0 with username as "admin" and password as "user".

CHAPTER 12 – SECTION 6 NICKEL-ZINC BATTERIES AND INTERFACE

12.6.1 Batteries and Battery Panels

12.6.1.1 Battery Type

The GT-BBS shall operate with Nickel-Zinc (NiZn) type batteries. The battery configuration shall consist of NiZn Battery Panel(s) with integrated or non-integrated charger modules.

12.6.1.2 Nickel-Zinc Battery Panel with Charging Units

The GT-BBS battery panel(s) shall utilize a Sealed Nickel-Zinc (NiZn) battery technology. The battery panel(s) shall be available in 300WH and 500WH capacity with C-Rate of C/4. The battery panel(s) shall be shelf or rack mountable or incorporate a bendable design, which allows the battery panel(s) to bend for installation in the space between the 19” EIA rack and the sidewall of the 332LS cabinet. The GT-BBS must allow the user to ‘Hot Swap’ the battery panel(s) while on utility power or battery backup power. The GT-BBS must be capable of accepting battery panel(s) of different capacities and/or different states of charge, giving the user the ability to utilize different battery sizes and batteries at various states of charge to achieve required run-times. The GT-BBS must allow the connection of a minimum of four (4) battery panels directly to the Inverter/Controller. The GT-BBS battery panel shall be capable of charging independently with a wall charging adaptor at 120 V AC Power Source.

A FORCE ON Switch shall be provided on each panel to “force” DC power on to the inverter if needed.

The FORCE ON Switch shall be located on the battery panel and shall “force” the battery panel to connect the Batteries to the Battery Pins so a Cabinet can be powered up during an existing power failure.

12.6.1.3 Battery Charging

The GT-BBS must recharge to full charge capacity within four (4) hours of complete discharge when AC utility line voltage is available.

12.6.2 Inverter to Batteries Interface

12.6.2.1 Connectors and BBS Harness

The Inverter to Batteries Interface connectors shall have quick Connect/Disconnect capability with thread assist, and positive detent coupling. The connectors shall be UL Recognized, UL 94 V-1 rated and made of stabilized, and heat resistant, self-extinguishing thermoplastic material. The BBS Harness shall be a minimum of 3ft in length as shown in the A12-5, comprising of a wire bundle with external protection. For the integrated charging NiZn Battery Panels, the BBS Harness shall provide Battery DC Power, Charging AC Power, an Isolated Power supply and Control Signals between the Inverter and the Battery Management System.

12.6.2.2 Battery DC Power

Battery DC Power terminals shall be de-energized during normal power conditions. During a Power Failure or if the FORCE-ON switch is depressed, the battery voltage shall be applied to Battery DC Power terminals (pins). The battery voltage shall range between 54 and 57 volts DC.

12.6.2.3 Charging AC Power

AC Utility Power shall be used to charge the batteries and power the circuitry in the Battery Management System in Battery Panels. When charging, the battery shall draw approximately 240 Watts if all of the battery strings are charging. If the batteries are full and not charging the current draw shall be about 10 Watts max.

The charging circuits shall be Power Factor corrected. Turned on surge current shall be less than 10 Amps. The conductor size shall be 18 AWG wire for the Charging AC Power circuits.

12.6.2.4 5V Power Supply

The inverter shall be provided with an integrated 5V Power Supply.

This power supply shall provide the power for all of the circuits in the battery interface. As a minimum the power supply shall supply 5 V @ 250 mA.

12.6.2.5 Control Signals

Control signals shall be provided between the Battery Management Systems (BMS) and the Inverter. See A12-4 –Battery Interface. The standard control signals required for the interface include Battery Present and Power Failure.

The control signals shall be electrically isolated and shall use the isolated 5V Power Supply located in the Inverter.

The “Battery Present Signal” shall be provided to inform the Inverter/Controller that a battery is connected to the system.

The “Power Failure Signal” shall be provided to inform the Battery Management System of a Power Failure. If the Power Failure Signal is asserted, the Battery DC Power shall be energized. The Battery DC Power shall be de-energized when the Power Fail signal shuts off.

CHAPTER 12-SECTION 7 WARRANTY

12.7.1 Terms and Conditions

Manufacturers shall provide a five (5) year warranty on the battery chemistry and a minimum of three (3) year warranty on all electronic components. The first three (3) years of the warranty period shall be termed the “Advanced Replacement Program”. Under this program, the manufacturer will send out a replacement within two business days of the call notifying them of an issue. The replacement unit may be either a new unit or a re-manufactured unit that is up to the latest revision. The last two years of the warranty will be factory-repair warranty for parts and labor on the GT-BBS.

CHAPTER 12-SECTION 8 QUALITY ASSURANCE

12.8.1 Quality Assurance

Each GT-BBS shall be manufactured in accordance with a manufacturer Quality Assurance (QA) program. The QA program shall include two Quality Assurance procedures: (1) Design QA (see Section 12.8.2 below) and (2) Production QA (see Section 12.8.3 below). The Production QA shall include statistically controlled routine tests to ensure minimum performance levels of BBS units built to meet this specification and a documented process of how problems are to be resolved.

12.8.1.1 QA Process

QA process and test results documentation shall be kept on file for a minimum period of seven years.

12.8.1.2 QA Approval

Battery Backup System designs not satisfying Design QA Testing and Production QA Testing requirements shall not be labeled, advertised, or sold as conforming to this specification.

12.8.2 Design Qualification Testing

The manufacturer, or an independent testing lab hired by the manufacturer, shall perform Design Qualification Testing on new BBS system(s) offered, and when any major design change has been implemented on an existing design. A major design change is defined as any modification, either in material, electrical, physical, or theoretical, that changes any performance characteristics of the system, or results in a different circuit configuration. Where a dispute arises in determining if a system is a new design or if the system has had a major design change, the State will make the final determination if Design Qualification Testing is required prior to production consideration.

12.8.2.1 Submittals

A quantity of two units for each design shall be submitted for Design Qualification Testing. Test units shall be submitted to Caltrans TransLab, Electrical Testing Branch after the manufacturer's testing is complete.

12.8.2.2 Test Data Submittal

Manufacturer's testing data shall be submitted with test units for Caltrans verification of the Design Qualification Testing.

12.8.2.3 Burn-In

The sample systems shall be energized for a minimum of 5 hours, at full rated load, at temperatures of +74 °C and -37 °C, excluding batteries, before performing any

design qualification testing. Any failure of the BBS, which renders the unit non-compliant with the specification after burn-in, shall be cause for rejection.

12.8.2.4 Testing

For Design Qualification Testing, as a minimum, the following will be tested for compliance to the specifications:

1. Minimum of two hours of run time while operating a minimum load of 480 Watts in Backup Mode.
2. Proper operations of all relay contacts
3. Inverter output voltage, frequency, harmonic distortion, and efficiency, when in Backup Mode.
4. All power transfer voltage levels and all modes of operation.
5. Power transfer time from loss of utility line voltage to stabilized inverter line voltage from batteries.
6. Back feed voltage to utility when in Backup Mode.
7. IEEE/ANSI C.62.41 compliance.
8. Battery charger operation.
9. Event counter and runtime meter accuracy.
10. User ability to control, monitor, get reports, and configure the system through the Ethernet ports.
11. Complete physical inspection of the system for quality workmanship.

12.8.3 Production Quality Control Testing

Production Quality Control tests shall consist of all the above listed tests and shall be performed on each new system prior to shipment. Failure to meet requirements of any of these tests shall be cause for rejection. The manufacturer shall retain test results for seven years.

12.8.3.1 100-Hour Burn-In-Period

Each BBS shall be given a minimum 100-hour burn-in period to eliminate any premature failures. The burn-in period can be a combination of running in Backup Mode with a full load and running in Charger Mode.

12.8.3.2 Visual Inspection

Each system shall be visually inspected for any exterior physical damage or assembly anomalies. Any defects shall be cause for rejection.

12.8.4 Caltrans Quality Assurance Testing

Caltrans will perform random sample testing on all shipments, consistent with ANSI/ASQC Z1.4-1993 Sampling Procedures and Tables for Inspection by Attributes.

12.8.4.1 Sample Testing

Sample testing will normally be completed within 30 days after delivery to the Caltrans Laboratory, barring deficiencies in the shipment, which would reset the clock. All parameters of the specification may be tested on the shipment sample.

12.8.4.2 Number of Units

The number of units tested (sample size) shall be determined by the quantity in the shipment. The sample size and acceptance or rejection of the shipment shall conform to ANSI/ASQC Z1.4.

CHAPTER 12-SECTION 9 GT-BBS DETAILS

12.9.1 GT-BBS System Block Diagram	Appendix A12-1
12.9.2 GT-BBS Utility Power Connection Diagram	A12-2
12.9.3 GT-BBS Relay Contact Terminal Block	A12-3
12.9.4 GT-BBS Battery Interface	A12-4
12.9.5 GT-BBS Harness	A12-5

GT- BBS Block Diagram

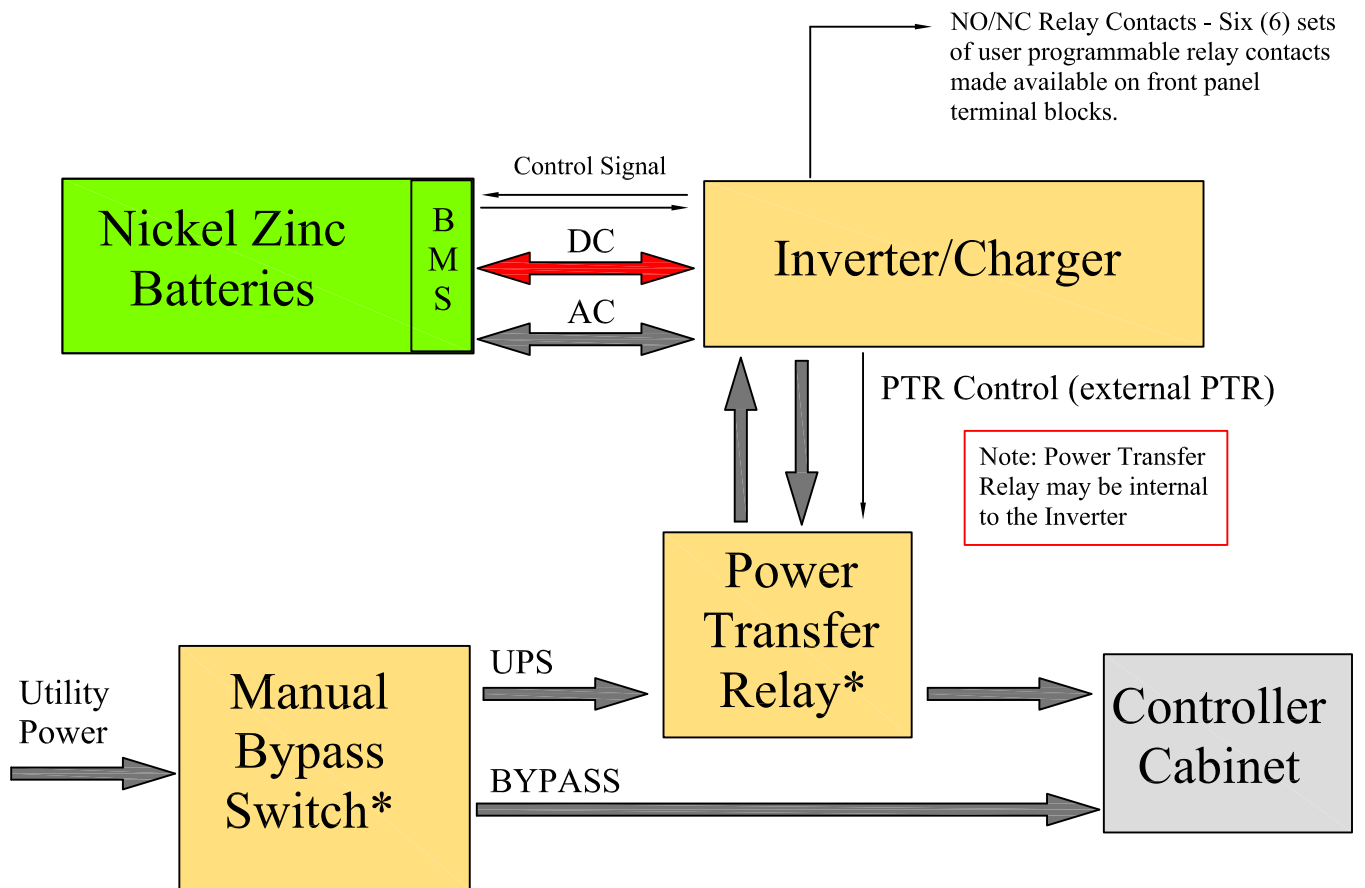

*Manual Bypass Switch (must be external to Inverter), and Power Transfer Relay must be separate functional units, but may share a common enclosure.

Note:

- 1. GT=Green Technology
- BMS=Battery Management System
- PTR=Power Transfer Relay

➡ AC VOLTAGE

➡ DC VOLTAGE

TITLE: GT-BBS Block Diagram	
ERRATA 3	NO SCALE
TEES 2009	A12-1

GT-BBS Utility Power Connection Diagram

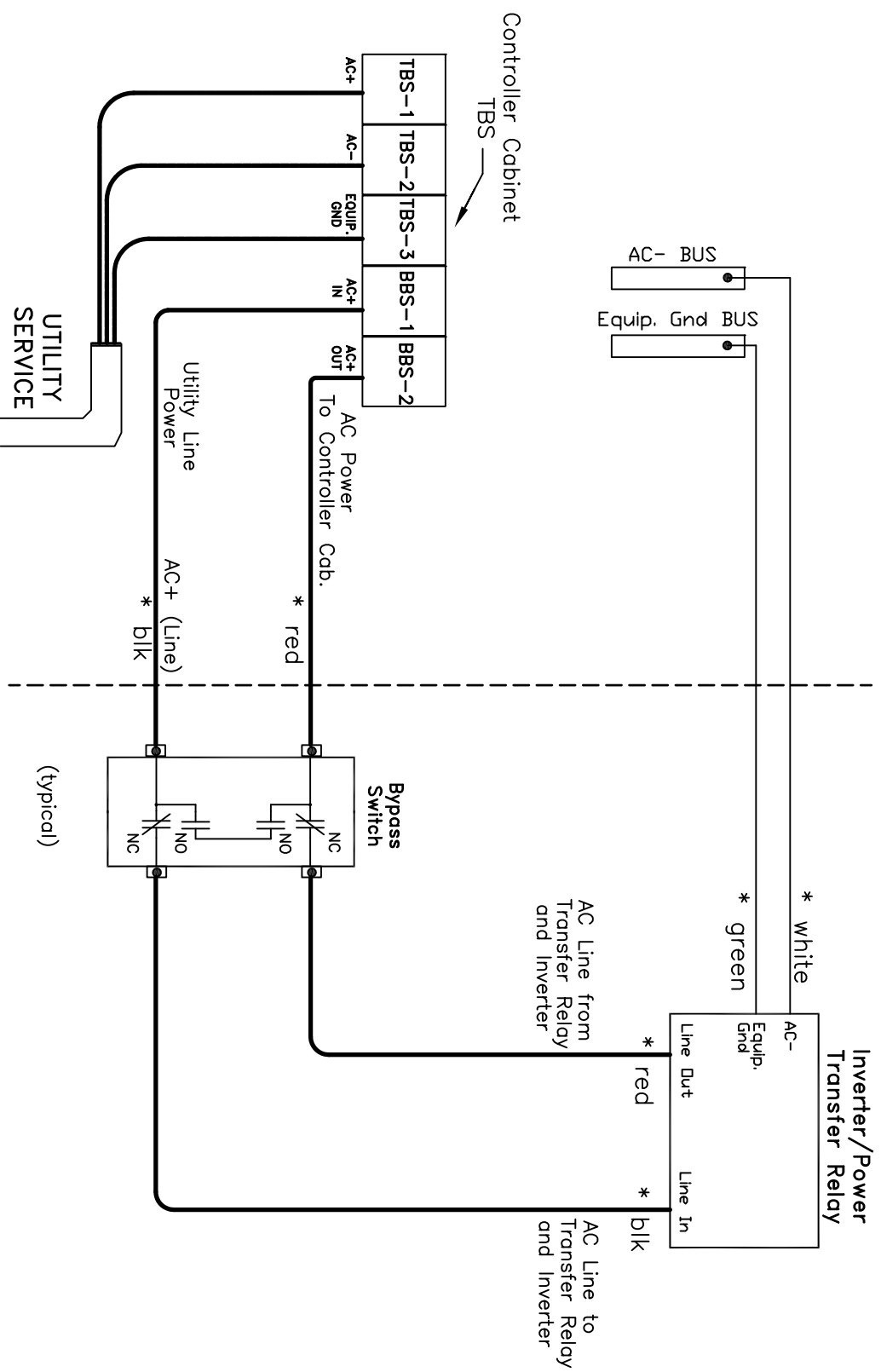

Note:

1. See A6-12 for conductor insulation colors.
2. All dimensions shown are in inches.

* As a minimum, these wires shall be provided in 9 ft lengths as part of the interconnect wiring kit.

TITLE	
GT-BBS Utility Power Connection Diagram	
ERRATA 3	NO SCALE
TEES 2009	A12-2

GT-BBS Relay Contact Terminal Block

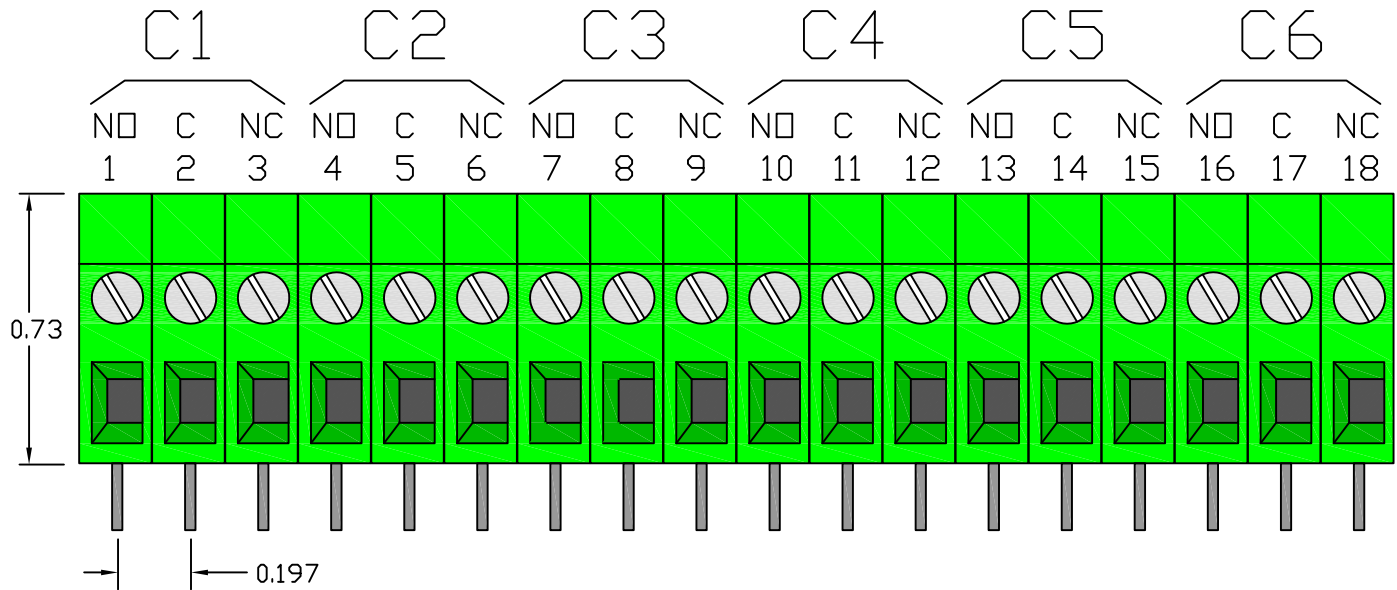

Note:

1. Available on Front Panel of Inverter/Charger.
2. 0.197 inch (5mm) spacing
3. Allows wire size 24–12 AWG
4. Screw and wire entrance are on the same face.
5. All dimensions shown are in inches.

TITLE:	GT-BBS Relay Contact Terminal Block	
	ERRATA 3	NO SCALE
	TEES 2009	A12-3

GT-BBS BATTERY INTERFACE

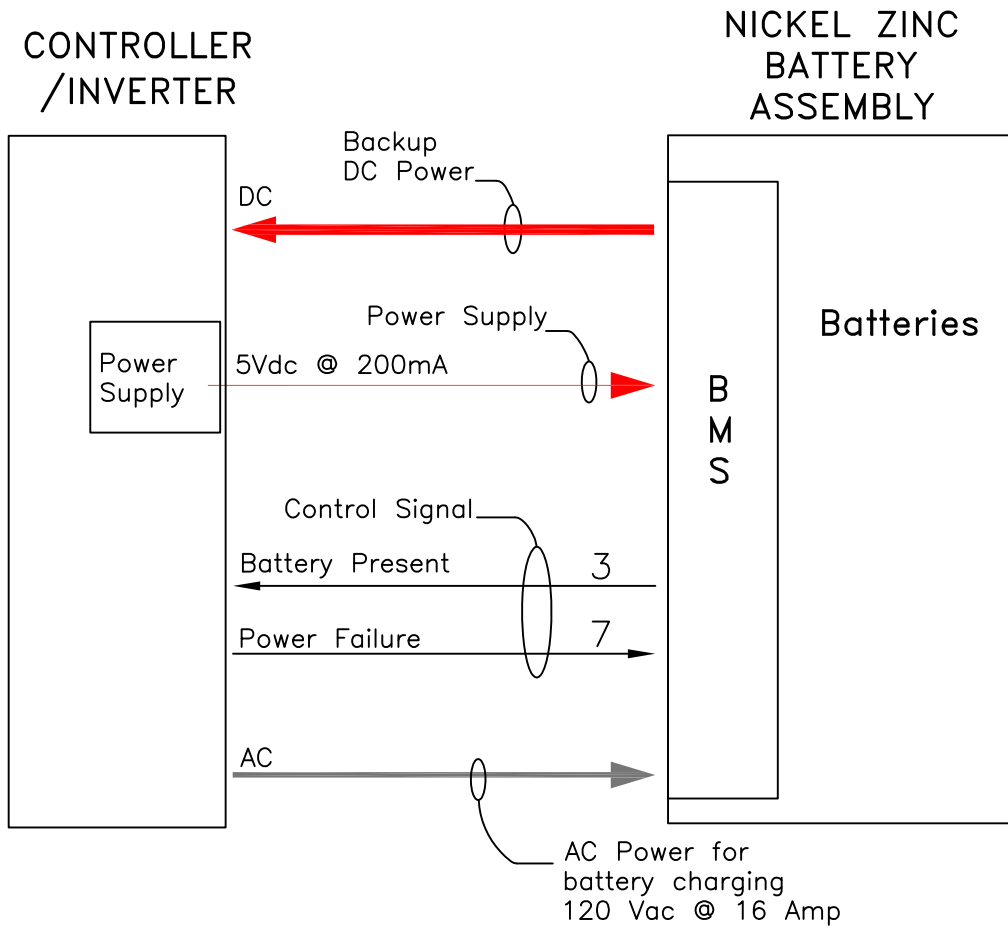

Notes: (For this detail)

1. BMS=Battery Management System
2. Backup DC power, 2 each
PS DC, 2 each
AC Power to battery charging, 4 each
3. All dimensions shown are in inches.

TITLE: GT-BBS Battery Interface	
ERRATA 3	NO SCALE
TEES 2009	A12-4

GT-BBS HARNESS

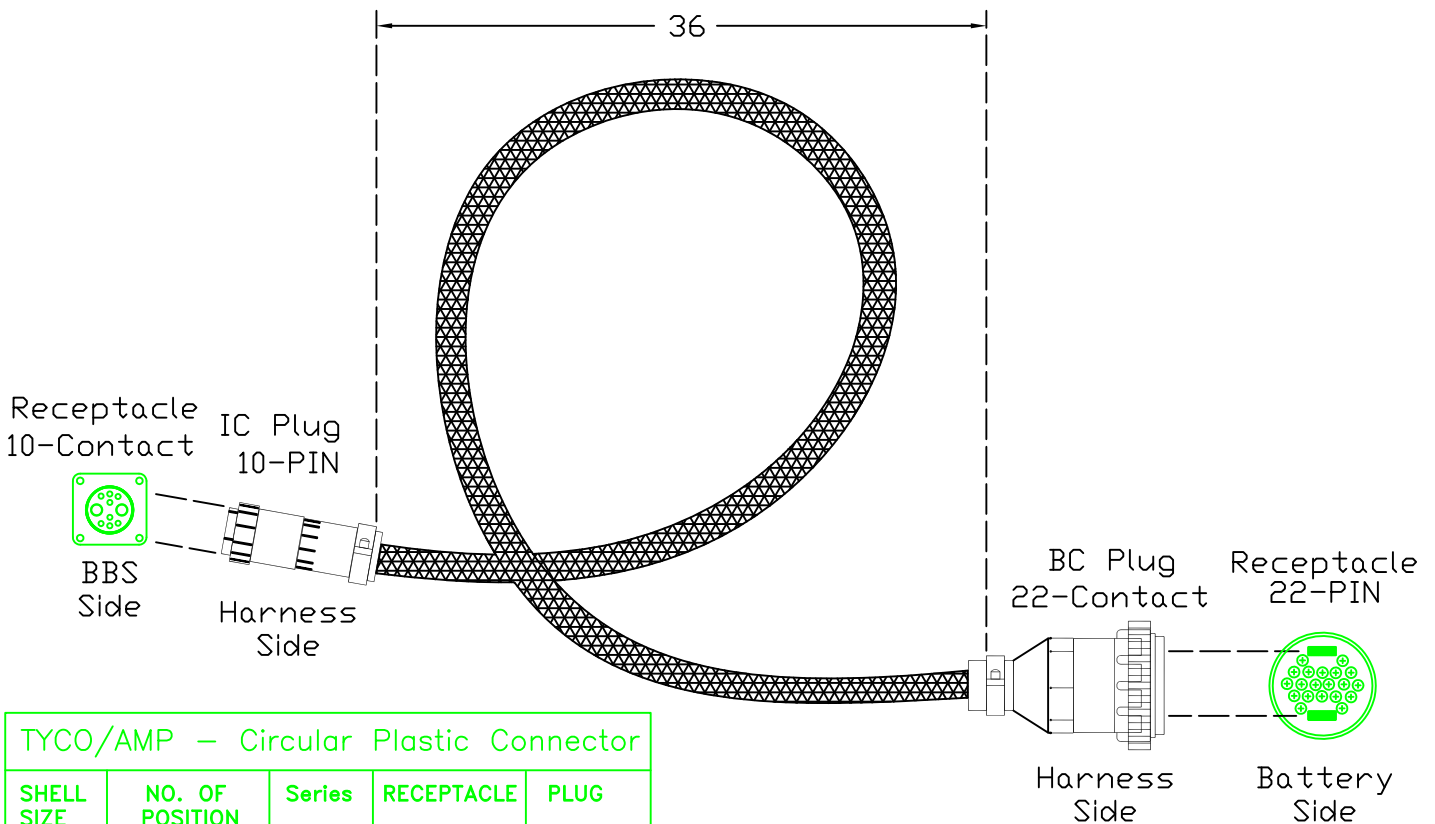

TYCO/AMP – Circular Plastic Connector				
SHELL SIZE	NO. OF POSITION	Series	RECEPTACLE	PLUG
17	10	6	213893-2	213906-1

TYCO/AMP – Circular Plastic Connector				
SHELL SIZE	NO. OF POSITION	Series	RECEPTACLE	PLUG
23	22	4	206613-3	206612-1

IC PLUG	FUNCTION	BC PLUG	Conductors
Pin	-	Pos	AWG
1	DC+	10	14
2	DC-	1	14
3	DC GND, 5V	7	18
4	BATTERY PRESENT	9	18
5	AC+	2	18
6	N/A	-	-
7	POWER FAILURE	8	18
8	DC+, 5V	4	18
9	AC-	22	18
10	Eq. GND	3	18

NOTE:

1. CPC 22 (20 + 2 Power)
CPC 10 (8 + 2 Power)
2. BC=Battery Connector
IC=Inverter Connector
3. All dimensions shown are in inches

TITLE:

GT-BBS HARNESS

Draft ERRATA 3

NO SCALE

TEES 2009

A12-5