



## 12-2 GUIDELINES FOR IDENTIFICATION OF STEEL BRIDGE MEMBERS

### General

The steel bridge members shall be identified as “*Fracture Critical Members (FCMs)*”, “*Main Members*”, “*Secondary Members*” or “*Primary Components of Main Members*” in order to:

- Implement “AASHTO/AWS Fracture Control Plan (**FCP**) for Nonredundant Members” specified by the current AASHTO/AWS D1.5 (2002), “Bridge Welding Code”. This ensures that steel bridges with critical tension components will be useful and serviceable during the design life.
- Ensure that main tension members or components conform to the supplementary toughness requirement specified by ASTM A 709/A 709M-01 (AASHTO M 270M/ M 270-02) S4 for “Non-Fracture-Critical, *T*, Material; Toughness Tests and Marking” and S5 for “Fracture-Critical, *F*, Material; Toughness Testing and Marking”.
- Implement Nondestructive Testing (NDT) specified by the current AASHTO/AWS D1.5 (2002), “Bridge Welding Code”.
- Comply with the federally mandated Fracture Critical Inspection Program requirements of the National Bridge Inspection Standards (1988), Code of Federal Regulations, 23 Highways, Part 650, Subpart C.

### Responsibility

It is the bridge designer’s responsibility to identify “*FCMs*”, “*Main Members*”, “*Secondary Members*” and “*Primary Components of Main Members*” in designing a new steel bridge and to designate or tabulate them explicitly on the contract documents (plans and/or Special Provisions). However, *FCMs* and *FCP* must not be used indiscriminately by the designer as a crutch “to be safe” and to circumvent good engineering practice.

## Definition

**Fracture Critical Members (FCMs)** - Tension members or tension components of bending members (including those subject to reversal of stress) whose failure would be expected to result in collapse of the bridge.

**Main Members** - Any members on a critical load path that carry bridge dead and live loads. The loss of capacity of those members would have serious consequences on the structural integrity.

**Secondary Members** - Any members other than main members, not designed to carry primary load.

## Identification Guidelines

### Fracture Critical Members (*FCMs*)

*FCMs* must be *main members* in tension or tension components of bending members (including those subject to reversal of stress) whose failure would cause the bridge to collapse. Redundant tension members are not *FCMs*. Redundancy means that should a tension member or tension component fail, the load carried by the failed member could be redistributed to and carried by remaining members to avoid catastrophic collapse of the structure.

The members or components, including but not limited to the following, shall be identified as *FCMs* only if their failure would cause a bridge to collapse:

- Tension ties in arch bridges
- Tension members in truss bridges
- Tension flanges and webs in two-girder bridges
- Tension flanges and webs in single or double box girder bridges
- Tension flanges and webs in floor beams/cross girders
- Tension braces in the cross frame of horizontally curved girder bridges
- Attachments welded to a *FCM* when their dimension exceeds 100 mm (4 in.) in the direction parallel to the calculated tensile stress in the *FCM*.
- Tension components of bent caps
- Splice plates of a *FCM*



The following members or components should not be identified as ***FCMs***:

- Members or components that are not subjected to tensile stresses under any conditions of live load
- Compression members and components
- Attachments welded to the compression areas of bending members
- Tension flanges and webs in multi-girder (3 girders and more) bridges

For those main tension members subjected to the seismic loads in an important bridge as defined in MTD 20-1, if there is a need to increase material and inspection requirements for those members similar to ***FCMs***, those members shall be clearly identified and their material and inspection requirements shall be explicitly specified on the contract documents (plans and/or Special Provisions)

It is considered undesirable from an operation and maintenance standpoint to have a bridge member yield. In general, the ***FCMs*** can be identified by removing the tension member or component and checking the remaining members to see if any members have yielded under both **unfactored dead and live loads**.

For a statically determinate truss bridge, all tension members are ***FCMs***. The flowchart shown in Fig. 1 may be used to locate ***FCMs*** for a complex bridge system.



## Main Members

The members or components, including but not limited to the following, shall be identified as *Main Members*:

- Beam/girders, bent caps
- End Cross frames/diaphragms
- Cross frames/diaphragms in horizontally curved girder bridges
- Columns, arch ribs and tower members
- Suspenders/tension ties and anchorage
- Truss diagonal and chord members

## Primary Components of Main Members

The following components, including but not limited to the following, shall be identified as *Primary Components of Main Members*:

- Flanges, webs, splice plates and cover plates
- Transverse and longitudinal stiffeners and bearing stiffeners
- Gusset plates, diaphragm sealing plates, stay plates and lacing
- Eye bars and hanger plates

## Design Implementation and Examples

- **All *Fracture Critical Members* shall be designated as “FCMs” explicitly on the contract documents (plans and/or Special Provisions). The temperature zone in which the structure will be constructed shall be noted in the Special Provisions.**
- **All *Main Members (Non-Fracture-Critical)* subjected to tensile stresses and tension components of bending members (including those subject to reversal of stress) shall be designated as “T” explicitly on the contract documents (plans and/or Special Provisions). The Charpy V-notch (CVN) impact values listed in Section 55.2.02 of the Standard Specifications are for Zone 2 for non-fracture-critical members. For service temperature from  $-35^{\circ}\text{C}$  ( $-31^{\circ}\text{F}$ ) to  $-51^{\circ}\text{C}$  ( $-60^{\circ}\text{F}$ ), Zone 3 CVN values shall be inserted into the Special Provisions.**

- **All Main Members** subjected to only compressive stresses and compression components of bending members shall be designated as “**C**” explicitly on the contract documents (plans and/or Special Provisions).
- All Main Members subjected to shear stresses shall be designated on the contract documents (plans and/or Special Provisions), unless identified by *FCM*, *T* or *C*.
- *Primary Components of Main Members* need not be designated explicitly. Instead, a note describing the primary components of main members should be added on the contract documents (plans and/or Special Provisions). For example, for a straight girder bridge, a note such as “*Primary Components of Main Members* are flanges, webs, splice plates and cover plates, transverse and longitudinal stiffeners and bearing stiffeners” should be added.
- *Secondary Members* need not be designated explicitly. Instead, a note such as “All members not designated as either *FCMs*, or *Main Members* are *Secondary Members*” should be added on the contract documents (plans and/or Special Provisions).

### Example 1 - FCM Designations

The following drawing shows *FCM* designations for a two-girder bridge.

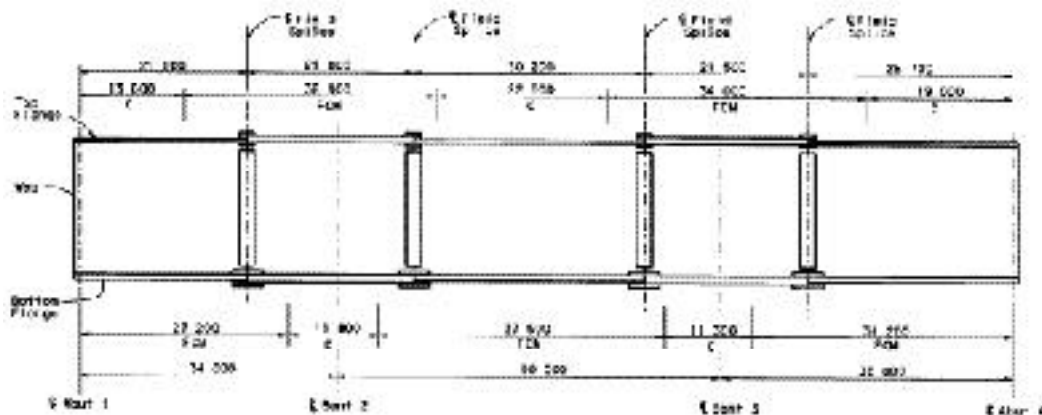

Notes:

FCM – Denotes Fracture Critical Member

C – Denotes Main Compression Member

FCM and C zones shown extend to the middle depth of the web

## Example 2 – Main Member Designations

The following drawing shows *Main Member* designations for a four-girder bridge.

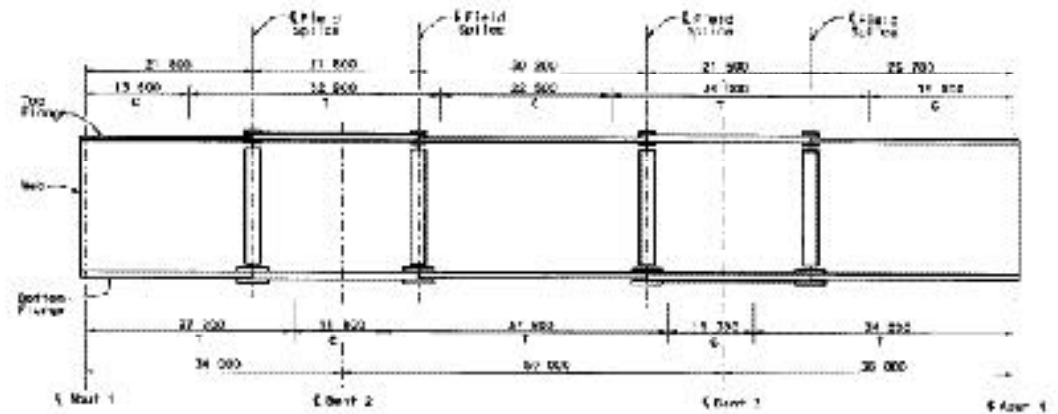

Notes:

T – Denotes Main Tension Member (Non-Fracture Critical Member)

C – Denotes Main Compression Member

T and C zones shown extend to the middle depth of the web

## Reference

AASHTO/AWS. 2002. *Bridge Welding Code*, AASHTO/AWS D1.5M/D1.5:2002, American Association of State Highway and Transportation Officials, Washington, D.C.

FHWA. 1988. *National Bridge Inspection Standards*, Federal Highway Administration, Washington, D.C.

---

Richard D. Land  
Deputy Chief, Division of Engineering Services,  
Structure Design