

DIST	COUNTY	ROUTE	POST MILES TOTAL PROJECT	SHEET NO.	TOTAL SHEETS

Glenn DeCou
 REGISTERED CIVIL ENGINEER
 No. C34547
 Exp. 9-30-09
 CIVIL
 REGISTERED PROFESSIONAL ENGINEER
 STATE OF CALIFORNIA

June 5, 2009
 PLANS APPROVAL DATE
 The State of California or its officers or agents shall not be responsible for the accuracy or completeness of electronic copies of this plan sheet.

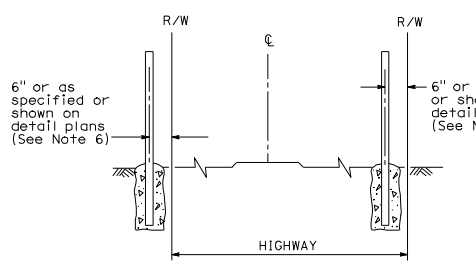

OTHER HIGHWAYS **FREEWAYS**

FENCE LOCATION

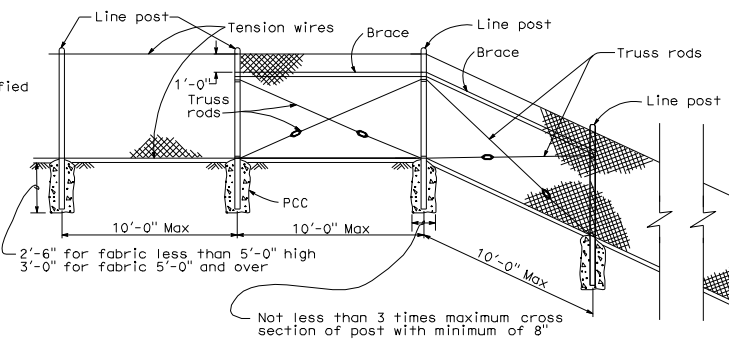

CHAIN LINK FENCE ON SHARP BREAK IN GRADE

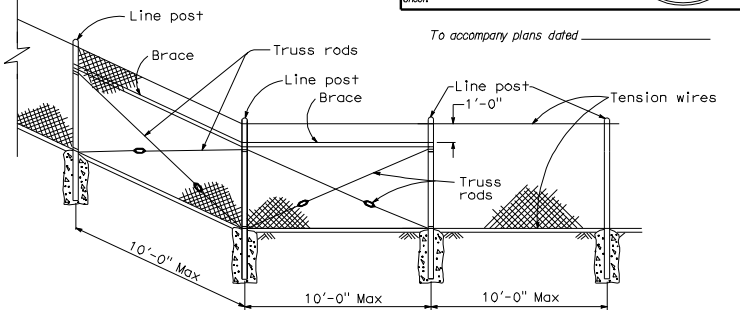

Brace to be removed after all other fence construction is completed unless otherwise directed by the Engineer

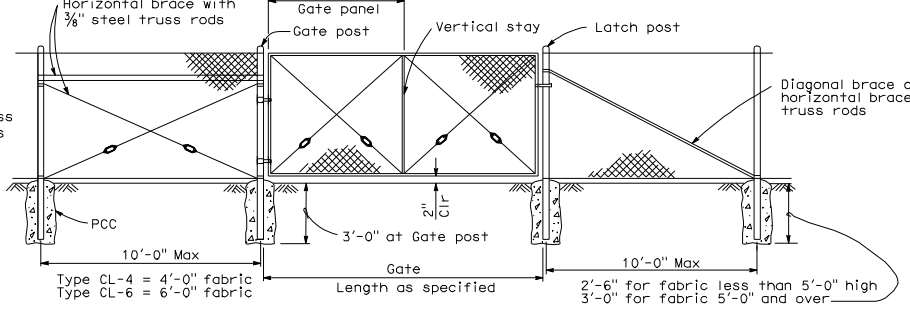
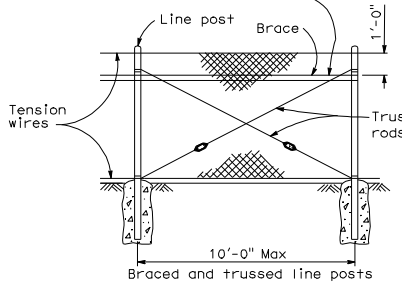

CHAIN LINK GATE INSTALLATION

GATE POST			
FENCE HEIGHT	GATE WIDTHS	NOMINAL ID	WEIGHT PER FOOT
6'-0" and Less	Up thru 6'-0"	2 1/2"	4.95 LB
	Over 6'-0" thru 12'-0"	4"	10.79 LB
	Over 12'-0" thru 18'-0"	5"	14.62 LB
	Over 18'-0" to 24'-0" Max	6"	18.97 LB
Over 6'-0"	Up thru 6'-0"	3"	7.58 LB
	Over 6'-0" thru 12'-0"	5"	14.62 LB
	Over 12'-0" thru 18'-0"	6"	18.97 LB
	Over 18'-0" to 24'-0" Max	8"	28.55 LB

Above post dimensions and weights are minimums. Larger sizes may be used on approval of the Engineer.

NOTES:

- The below table shows examples of post and brace sections which may comply with the Specifications.
- Sections shown in the tables must also comply with the strength requirements and other provisions of the Specifications.
- Other sections which comply with the strength requirements and other provisions of the Specifications may be used on approval of the Engineer.
- Options exercised shall be uniform on any one project.
- Dimensions shown are nominal.
- Offset to be 2'-0" at monument locations, measured at right angles to R/W lines. Taper to achieve offset to be at least 20'-0" long.

FENCE HEIGHT	TYPICAL MEMBER DIMENSIONS (See Notes)									
	LINE POSTS			END, LATCH & CORNER POSTS		BRACES				
	ROUND ID	H	ROLL FORMED	ROUND ID	ROLL FORMED	ROUND ID	H	ROLL FORMED		
6' & less	1 1/2"	1 7/8" x 1 5/8"	1 3/8" x 1 5/8"	2"	3 1/2" x 3 1/2"	2" x 1 3/4"	1 1/4"	1 1/2" x 1 5/8"	1 5/8" x 1 1/4"	1 3/4" x 1 1/4"
Over 6'	2"	2 1/4" x 2"	2" x 1 3/4"	2 1/2"	3 1/2" x 3 1/2"	2 1/2" x 2 1/2"	1 1/4"	1 1/2" x 1 5/8"	1 5/8" x 1 1/4"	1 3/4" x 1 1/4"

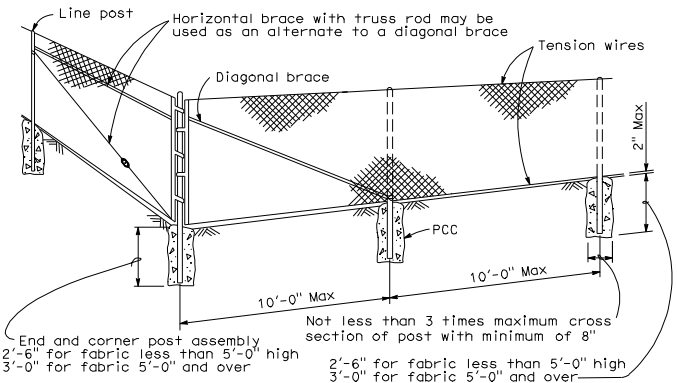

CORNER POST

STATE OF CALIFORNIA
DEPARTMENT OF TRANSPORTATION

CHAIN LINK FENCE

NO SCALE

RSP A85 DATED JUNE 5, 2009 SUPERSEDES STANDARD PLAN A85
DATED MAY 1, 2006 - PAGE 111 OF THE STANDARD PLANS BOOK DATED MAY 2006.

REVISED STANDARD PLAN RSP A85

2006 REVISED STANDARD PLAN RSP A85