

## CHAPTER 650 PAVEMENT DRAINAGE

### Topic 651 - General Considerations

#### Index 651.1 - Impacts of Drainage on Pavement

Saturation of the pavement or underlying subgrade, or both, generally results in a decrease in strength or ability to support heavy axle loads. Potential problems associated with saturation of the structural section and subgrade include:

- Pumping action.
- Differential expansion (swelling) of expansive subgrade.
- Frost damage in freeze-thaw areas.
- Erosion and piping of fine materials creating voids which result in the loss of subgrade support.
- Icing of pavement surface from upward seepage.
- Stripping of asphalt concrete aggregates.
- Accelerated oxidation of asphalt binder.

Water can enter the pavement as surface water through cracks, joints, and pavement infiltration, and as groundwater from an intercepted aquifer, a high water table, or a localized spring. These sources of water should be considered and provisions should be made to handle both. The pavement structure drainage system, which is engineered to handle surface water inflow, is generally separated from the subsurface drainage system that is engineered to accommodate encroaching subsurface water. This chapter covers surface water drainage while the subsurface drainage system is covered in Chapter 840.

#### 651.2 Drainage System Components and Requirements

The basic components of a pavement structural section drainage system are:

- (1) *Drainage Layer.* A treated permeable base (TPB) drainage layer may be useful where it is

necessary to drain water beneath the pavement. A TPB requires the use of edge drains or some other method of draining water out and away from the pavement; otherwise the collected water will become trapped. If a TPB drainage layer is used, it should be placed immediately below the surface layer for interception of surface water that enters the pavement. The drainage layer limits are shown in Figure 651.2A. Further information for TPB can be found in Index 662.3.

When there is concern that the infiltrating surface water may saturate and soften the underlying subbase or subgrade (due either to exposure during construction operations or under service conditions), a filter fabric or other suitable membrane should be utilized and applied to the base, subbase, or subgrade on which the TPB layer is placed to prevent migration of fines and contamination of the TPB layer by the underlying material.

When using TPB, special attention should be given to drainage details wherever water flowing in the TPB encounters impermeable abutting pavement layers, a structure approach slab, a sleeper slab, a pavement end anchor/transition, or a pressure relief joint. In any of these cases, a cross drain interceptor should be provided. Details of cross drain interceptors at various locations are shown in Figure 651.2B. The cross drain outlets should be tied into the longitudinal edge drain collector and outlet system with provision for maintenance access to allow cleaning.

In some situations, underground water from landscape irrigation or other sources may tend to saturate the existing slow-draining layers, thereby creating the potential for pumping and pavement damage. In this case, the pavement should be engineered to provide for removal of such water when reconstruction is required.

- (2) *Collector System.* If constraints exist or where it is not practical to drain water out of the pavement by other means, a collector system should be provided to drain water from the drainage layer. Collector systems include a 3-inch slotted plastic pipe edge drain installed in a longitudinal collector trench as shown in Figure 651.2A. In areas where the profile grade

**Figure 651.2A**  
**Typical Section with Treated Permeable Base Drainage Layer**

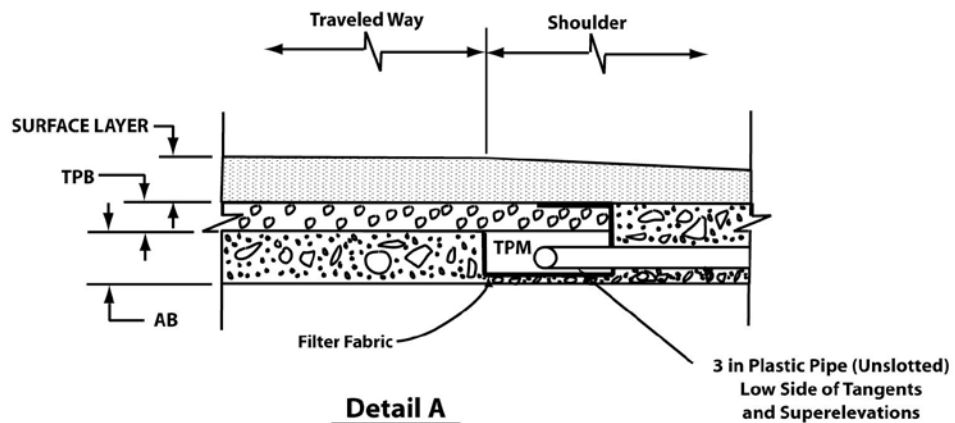
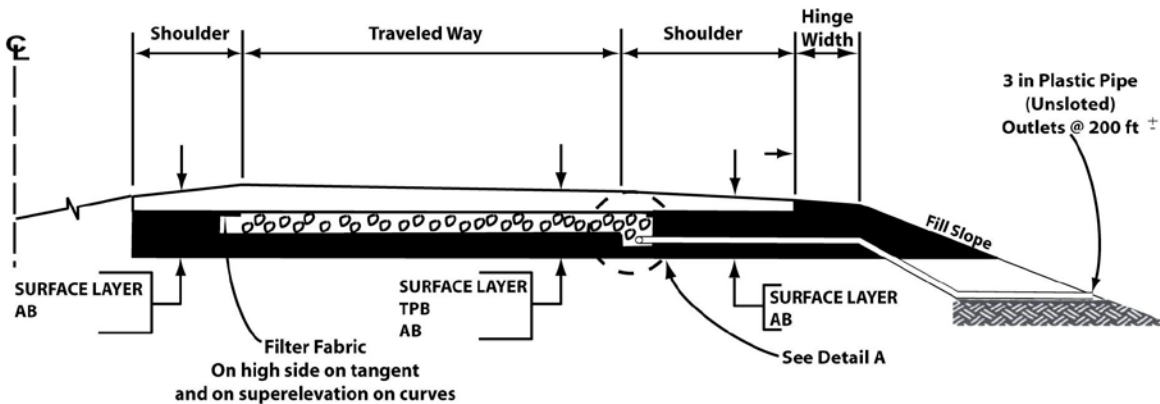
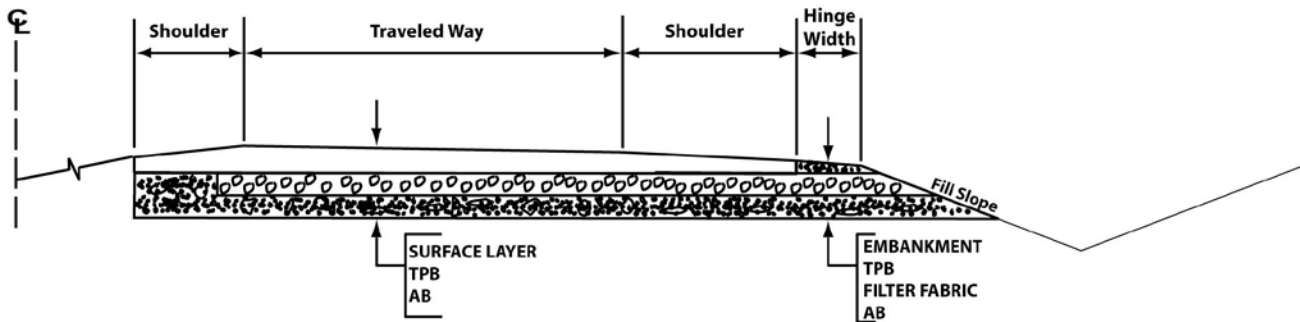

**Detail A**  
 See Std. Plans D99A through D99D  
 For Additional Information

**NOTES:**

- (1) Section shown is a half-section of a divided highway. An edge drain collector and outlet system should be provided if insufficient Right of Way precludes a retention basin.
- (2) This figure is only intended to show typical pavement details, for geometric cross section details, see Chapter 300.

Figure 651.2B

Cross Drain Interceptor Details For Use with Treated Permeable Base

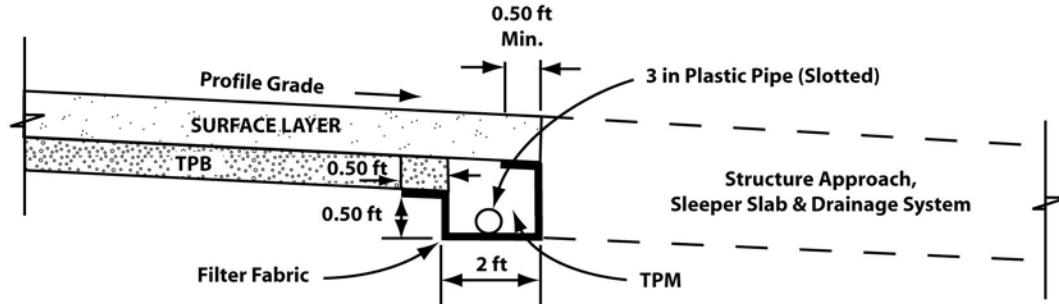

**AT STRUCTURE APPROACH  
(LONGITUDINAL SECTION)**

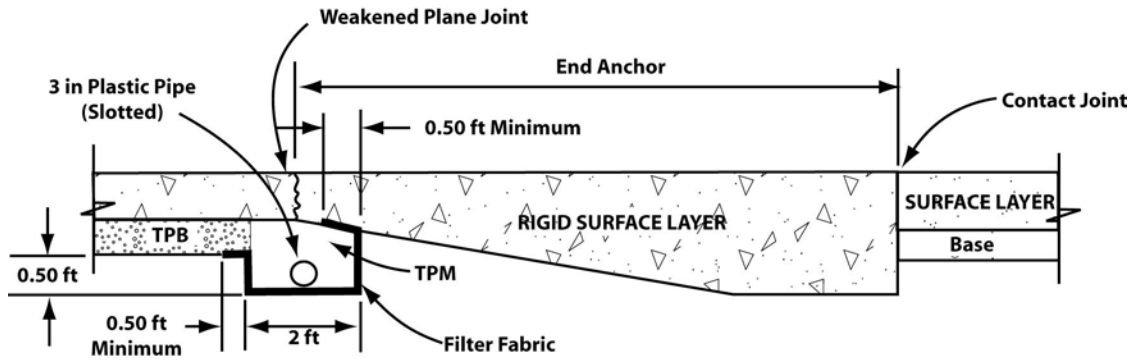

**AT END ANCHOR  
(LONGITUDINAL SECTION)**

is equal to or greater than 4 percent, intermediate cross drain interceptors, as shown in Figure 651.2C should be provided at an approximate spacing of 500 feet. This will limit the longitudinal seepage distance in the drainage layer, minimizing the drainage time and preventing the buildup of a hydrostatic head under the surface layer. Cross drain interceptor trenches must be sloped to drain.

In addition, cross drains need to be provided at the low-end terminal of TPB projects, as shown in Figure 651.2C. Care should be taken to coordinate the cross drains with the longitudinal structural section drainage system. Drainage layers in roadway intersections and interchanges may require additional collector trenches, pipes, and outlets to assure rapid drainage of the pavement.

A standard longitudinal collector trench width of 1 foot has been adopted for new construction to accommodate compaction and consolidation of the TPB alongside and above the 3-inch slotted plastic pipe.

When a superelevation cross slope begins to drain the water through the TPB to the low side of pavement in cut sections, an edge drain system may be considered to direct water to an area where ponding will not occur.

- (3) *Outlets, Vents, and Cleanouts.* Pavements should be engineered to promote free drainage whenever applicable. Alternative strategies are provided, as shown in Figure 651.2A. Incorporation of a TPB daylighting to the edge of embankment may be considered; otherwise, an edge drain collector and outlet system may provide positive drainage of the structural section.

When edge drains are used, plastic pipe (unslotted) outlets should be provided at proper intervals for the pavement drainage system to be free draining. The spacing of outlets (including vents and cleanouts) should be approximately 200 feet (250 feet maximum). Outlets should be placed on the low side of superelevations or blockages such as bridge structures.

The trench for the outlet pipe must be backfilled with material of low permeability, or

provided with a cut-off wall or diaphragm, to prevent piping.

The outlets must be daylighted, connected to culverts or drainage structures, or discharged into gutters or drainage ditches. The area under the exposed end of a daylighted outlet should have a splash block or be paved to prevent erosion and the growth of vegetation, which will impede flows from the outlet. Ready access to outlets, and the provision of intervening cleanouts when outlet spacing exceeds a maximum distance of 250 feet, should be provided to facilitate cleaning of the pavement drainage system. Typical details are shown on the Standard Plans for Edge Drain Outlet and Vent Details.

The end of each outlet pipe should be indicated by an appropriate marker to facilitate location and identification for maintenance purposes and to reduce the likelihood of damage by vehicles and equipment. Consult the District Division of Maintenance for the preferred method of identification.

- (4) *Filter Fabric.* Filter fabric should be placed as shown in Figures 651.2A and B, respectively, to provide protection against clogging of the treated permeable material (TPM) by intrusion of fines. Filter fabric should be selected based upon project specific materials conditions to ensure continuous flow of water and preclude clogging of the filter fabric openings. Consult with the District Materials Engineer to assist in selecting the most appropriate filter fabric for the project.

## Topic 652 - Subsurface Drainage and Storm Water Management

Subsurface drainage (edge drains and underdrains) is to be handled in accordance with the procedures provided in Chapter 890 of the HDM for conveyance and with the procedures in the Storm Water Quality Handbook - Project Planning and Design Guide (PPDG) for storm water compliance. Storm Water Best Management Practices (BMPs) are to be incorporated in the design of projects as prescribed in the PPDG. The PPDG and other information on storm water management can be

Figure 651.2C

Cross Drain Interceptor Trenches

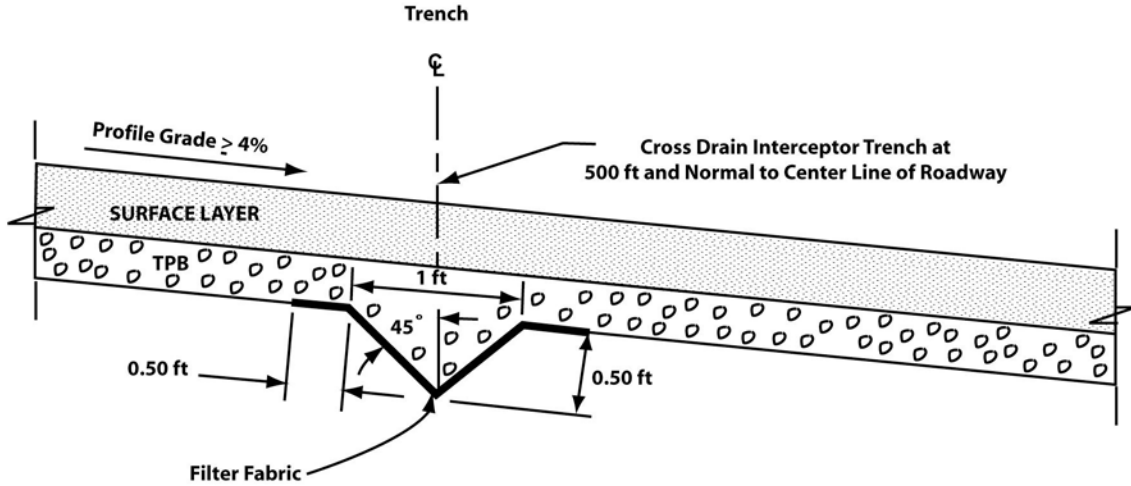

Intermediate Cross Drain  
(Longitudinal Section)

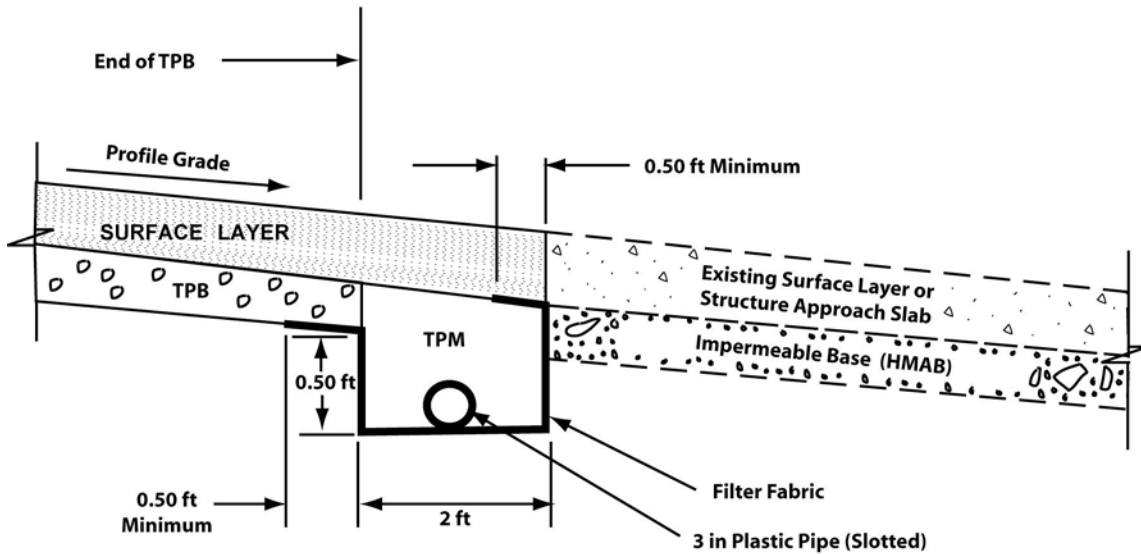

Terminal Cross Drain  
(Longitudinal Section)

found at Storm Water page of the Division of Design website.

## **Topic 653 – Other Considerations**

### **653.1 New Construction Projects**

The surface layer should employ materials that will minimize surface water intrusion and any joints should be sealed. If sufficient right of way is available, it is preferable to grade the roadbed to allow for a free draining outlet for the pavement rather than installing edge drain. When a free drainage outlet is used, the TPB and AB layers of the pavement must be daylighted on the low end of the section.

On curvilinear alignments, superelevation of the roadway may create depressions at the low side of pavement where the collected water cannot be drained away. An adjustment to the profile grade may be necessary to eliminate these depressions. Refer to Chapter 200 for superelevation guidelines.

### **653.2 Widening Projects**

The widened pavement layers should be engineered to discharge any existing water collected by the pavement. This may be done by extending any drainage layer of the existing adjacent pavement while still providing sufficient pavement structure to meet the pavement design life requirements in Topic 612. The widened layers should extend the full width of the roadbed to a free outlet, if feasible, as in new construction (See Figure 651.2A).

### **653.3 Rehabilitation and Reconstruction Projects**

The surface of the traveled way and shoulders should employ methods and materials that will help minimize surface water intrusion and any joints should be sealed. Saturation or soft spots should be identified and drainage system should be incorporated to restore or repair the existing pavement, if applicable.

### **653.4 Ramps**

Provisions for positive, rapid drainage of the structural section is very important on ramps as much as main lanes. However, including drainage systems in ramp pavements can sometimes create drainage problems such as accumulation of water in

the subgrade of descending ramps approaching local street intersections in flat terrain. Such situations, where there may be no cost effective way to provide positive drainage outlets, call for careful evaluation of local conditions and judgment in determining whether a drainage system should be included or not in each ramp pavement structure.

### **653.5 Roadside Facilities**

The surface of parking areas should be crowned or sloped to minimize the amount of surface water penetrating into the pavement. Drainage facilities for the surface runoff should be provided if flexible pavement is used. A mix using  $\frac{3}{8}$  inch or  $\frac{1}{2}$  inch maximum aggregate is recommended to provide a relatively low permeability. The flexible pavement should be placed in one lift to provide maximum density.