

SECTION 3 LOADS

Part A Type of Loads

3.1 NOTATIONS

<p>A = maximum expected acceleration of bed rock at the site</p> <p>a = length of short span of slab (Article 3.24.6)</p> <p>B = buoyancy (Article 3.22)</p> <p>b = width of pier or diameter of pile (Article 3.18.2.2.4)</p> <p>b = length of long span of slab (Article 3.24.6)</p> <p>C = combined response coefficient</p> <p>C = stiffness parameter = $K(W/L)$ (Article 3.23.4.3)</p> <p>C = centrifugal force in percent of live load (Article 3.10.1)</p> <p>CF = centrifugal force (Article 3.22)</p> <p>C_n = coefficient for nose inclination (Article 3.18.2.2.1)</p> <p>C_M = steel bending stress coefficient (Article 3.25.1.5)</p> <p>C_R = steel shear stress coefficient (Article 3.25.1.5)</p> <p>D = parameter used in determination of load fraction of wheel load (Article 3.23.4.3)</p> <p>D = degree of curve (Article 3.10.1)</p> <p>D = dead load (Article 3.22)</p> <p>D.F. = fraction of wheel load applied to beam (Article 3.28.1)</p> <p>DL = contribution dead load</p> <p>E = width of slab over which a wheel load is distributed (Article 3.24.3)</p> <p>E = earth pressure (Article 3.22)</p> <p>EQ = equivalent static horizontal force applied at the center of gravity of the structure</p> <p>E_c = modulus of elasticity of concrete (Article 3.26.3)</p> <p>E_s = modulus of elasticity of steel (Article 3.26.3)</p> <p>E_w = modulus of elasticity of wood (Article 3.26.3)</p> <p>F = horizontal ice force on pier (Article 3.18.2.2.1)</p> <p>+ F = framing factor</p> <p>F_b = allowable bending stress (Article 3.25.1.3)</p>	<p>F_v = allowable shear stress (Article 3.25.1.3)</p> <p>g = 32.2 ft./sec.²</p> <p>I = impact fraction (Article 3.8.2)</p> <p>ICE = ice pressure (Article 3.22)</p> <p>J = gross Saint-Venant torsional constant of the precast member (Article 3.23.4.3)</p> <p>K = stream flow force constant (Article 3.18.1)</p> <p>K = stiffness constant (Article 3.23.4)</p> <p>K = wheel load distribution constant for timber flooring (Article 3.25.1.3)</p> <p>k = live load distribution constant for spread box girders (Article 3.28.1)</p> <p>L = loaded length of span (Article 3.8.2)</p> <p>L = load length of sidewalk (Article 3.14.1.1)</p> <p>L = live load (Article 3.22)</p> <p>L = span length (Article 3.23.4)</p> <p>LF = longitudinal force from live load (Article 3.22)</p> <p>M_D = moment capacity of dowel (Article 3.25.1.4)</p> <p>M_x = primary bending moment (Article 3.25.1.3)</p> <p>\bar{M}_y = total transferred secondary moment (Article 3.25.1.4)</p> <p>N_B = number of beams (Article 3.28.1)</p> <p>N_L = number of traffic lanes (Article 3.23.4)</p> <p>n = number of dowels (Article 3.25.1.4)</p> <p>P = live load on sidewalk (Article 3.14.1.1)</p> <p>P = stream flow pressure (Article 3.18.1)</p> <p>P = total uniform force required to cause unit horizontal deflection of whole structure</p> <p>P = load on one rear wheel of truck (Article 3.24.3)</p> <p>P = wheel load (Article 3.24.5)</p> <p>P = design wheel load (Article 3.25.1)</p> <p>P_{15} = 12,000 pounds (Article 3.24.3)</p> <p>P_{20} = 16,000 pounds (Article 3.24.3)</p> <p>p = effective ice strength (Article 3.18.2.2.1)</p> <p>p = proportion of load carried by short span (Article 3.24.6.1)</p> <p>R = radius of curve (Article 3.10.1)</p> <p>R = normalized rock response</p>
--	--

R = rib shortening (Article 3.22)
 R_D = shear capacity of dowel (Article 3.25.1.4)
 R_x = primary shear (Article 3.25.1.3)
 $\frac{R_x}{R_y}$ = total secondary shear transferred (Article 3.25.1.4)
 S = design speed (Article 3.10.1)
 S = soil amplification spectral ratio
 S = shrinkage (Article 3.22)
 S = average stringer spacing (Article 3.23.2.3.1)
 S = spacing of beams (Article 3.23.3)
 S = parameter used in determining the load fraction to be applied to precast concrete beams (Article 3.23.4.3)
 S = effective span length (Article 3.24.1)
 S = span length (Article 3.24.8.2)
 S = beam spacing (Article 3.28.1)
 s = effective deck span (Article 3.25.1.3)
 SF = stream flow (Article 3.22)
 T = period of vibration
 T = temperature (Article 3.22)
 t = thickness of ice (Article 3.18.2.2.4)
 t = deck thickness (Article 3.25.1.3)
 V = variable spacing of truck axles (Figure 3.7.3A)
 V = velocity of water (Article 3.18.1)
 W = combined weight on the first two axles of a standard HS Truck (Figure 3.7.3A)
 W = width of sidewalk (Article 3.14.1.1)
 W = wind load on structure (Article 3.22)
 W = total dead weight of the structure
 W_e = width of exterior girder (Article 3.23.2.3.2)
 W = overall width of bridge (Article 3.23.4.3)
 W = roadway width between curbs (Article 3.28.1)
 WL = wind load on live load (Article 3.22)
 w = width of pier or diameter of circular-shaft pier at the level of ice action (Article 3.18.2.2.1)
 X = distance from load to point of support (Article 3.24.5.1)
 x = subscript denoting direction perpendicular to longitudinal stringers (Article 3.25.1.3)
 Z = reduction for ductility and risk assessment
 β = (with appropriate script) coefficient applied to loads for service load and load factor designs (Article 3.22)
 γ = load factor (Article 3.22)
 σ_{PL} = proportional limit stress perpendicular to grain (Article 3.25.1.4)
 β_B = load combination coefficient for buoyancy (Article 3.22.1)
 β_C = load combination coefficient for centrifugal force (Article 3.22.1)

β_D = load combination coefficient for dead load (Article 3.22.1)
 β_E = load combination coefficient for earth pressure (Article 3.22.1)
 β_{EQ} = load combination coefficient for earthquake (Article 3.22.1)
 β_{ICE} = load combination coefficient for ice (Article 3.22.1)
 β_L = load combination coefficient for live load (Article 3.22.1)
 β_R = load combination coefficient for rib shortening, shrinkage and temperature (Article 3.22.1)
 β_S = load combination coefficient for stream flow (Article 3.22.1)
 β_W = load combination coefficient for wind (Article 3.22.1)
 β_{WL} = load combination coefficient for wind on live load (Article 3.22.1)
 μ = Poisson's ratio (Article 3.23.4.3)

3.2 GENERAL

3.2.1 Structures shall be designed to carry the following loads and forces:

Dead load.
 Live load.
 Impact or dynamic effect of the live load.
 Wind loads.
 Other forces, when they exist, as follows:
 Longitudinal forces, centrifugal force, thermal forces,
 earth and drift pressure, buoyancy, shrinkage stresses, +
 rib shortening, erection stresses, ice and current +
 pressure, earthquake stresses, prestressing and +
 friction forces. +

3.2.2 Members shall be proportioned using the allowable stresses permitted by the design procedure and the limitations imposed by the material. +

3.2.3 When stress sheets are required, a diagram or notation of the assumed loads shall be shown and the stresses due to the various loads shall be shown separately.

3.2.4 Where required by design conditions, the concrete placing sequence shall be indicated on the plans or in the special provisions.



3.2.5 The loading combination shall be in accordance with Article 3.22.

3.2.6 When a bridge is skewed, the loads and forces carried by the bridge through the deck system to pin connections and hangers should be resolved into vertical, lateral, and longitudinal force components to be considered in the design.

3.3 DEAD LOAD

3.3.1 The dead load shall consist of the weight of the entire structure, including the roadway, sidewalks, car tracks, pipes, conduits, cables, and other public utility services.

3.3.2 The snow and ice load is considered to be offset by an accompanying decrease in live load and impact and shall not be included except under special conditions.

3.3.2.1 If differential settlement is anticipated in a structure, consideration should be given to stresses resulting from this settlement.

3.3.3 If a separate wearing surface is to be placed when the bridge is constructed, or is expected to be placed in the future, adequate allowance shall be made for its weight in the design dead load.

3.3.4 Special consideration shall be given to the necessity for a separate wearing surface for those regions where the use of chains on tires or studded snow tires can be anticipated.

3.3.5 Where the abrasion of concrete is not expected, the traffic may bear directly on the concrete slab. If considered desirable, 1/4 inch or more may be added to the slab for a wearing surface.

3.3.6 The following weights are to be used in computing the dead load:

	<u>#/cu. ft</u>
Steel or cast steel	490
Cast iron	450
Aluminum alloys	175
Timber (treated or untreated)	50
Concrete, plain or reinforced	150

Compacted sand, earth, gravel, or ballast	120
Loose sand, earth, and gravel	100
Macadam or gravel, rolled	140
Cinder filling	60
Pavement, other than wood block	150
Railway rails, guard rails, and fastenings (per linear foot of track)	200
Stone masonry	170
Asphalt plank, 1 in. thick	9 lb. sq. ft.

3.4 LIVE LOAD

The live load shall consist of the weight of the applied moving load of vehicles, cars, and pedestrians.

3.5 OVERLOAD PROVISIONS

Structures which carry vehicular traffic shall be analyzed for overloads that are represented by P loads as described in Article 3.7, and other specific loads where applicable. Application shall be in accordance with Article 3.22.

3.6 TRAFFIC LANES

3.6.1 The lane loading or standard truck shall be assumed to occupy a width of 10 feet.

3.6.2 The loads shall be placed in 12-foot wide design traffic lanes, spaced across the entire bridge roadway width measured between curbs.

3.6.3 Fractional parts of design lanes shall not be used, but roadway widths from 20 to 24 feet shall have two design lanes each equal to one-half the roadway width.

3.6.4 The traffic lanes shall be placed in such numbers and positions on the roadway, and the loads shall be placed in such positions within their individual traffic lanes, so as to produce the maximum stress in the member under consideration.

3.6.5 These provisions shall not apply to those superstructure members for which wheel load application without regard to placement in traffic lanes is specified in Articles 3.23 thru 3.28, 6.4 and 10.39.



3.7 HIGHWAY LOADS

3.7.1 Standard Truck and Lane Loads*

3.7.1.1 The highway live loadings on the roadways of bridges or incidental structures shall consist of standard trucks or lane loads that are equivalent to truck trains. Three systems of loading are provided. The H loadings and the HS loadings-the HS loadings being heavier than the corresponding H loadings and P loads based on permit vehicles for regulation of overloads.

3.7.1.2 Each lane load shall consist of a uniform load per linear foot of traffic lane combined with a single concentrated load (or two concentrated loads in the case of continuous spans-see Article 3.11.3), so placed on the span as to produce maximum stress. The concentrated load and uniform load shall be considered as uniformly distributed over a 10 foot width on a line normal to the centerline of the lane.

3.7.1.3 For the computation of moments and shears, different concentrated loads shall be used as indicated in Figure 3.7.6B. The lighter concentrated loads shall be used when the stresses are primarily bending stresses, and the heavier concentrated loads shall be used when the stresses are primarily shearing stresses.

3.7.2 Classes of Loading

There are four standard classes of highway loading: H 20, H 15, HS 20, and HS 15. Loading H 15 is 75 percent of loading H 20. Loading HS 15 is 75 percent of Loading HS 20. If loadings other than those designated are desired, they shall be obtained by proportionately changing the weights shown for both the standard truck and the corresponding lane loads.

*Note: The system of lane loads defined here (and illustrated in Figure 3.7.6B) was developed in order to give a simpler method of calculating moments and shears than that based on wheel loads of the truck.

Appendix B shows the truck train loadings of the 1935 Specifications of AASHTO and the corresponding lane loadings.

In 1944, the HS series of trucks was developed. These approximate the effect of the corresponding 1935 truck preceded and followed by a train of trucks weighing three-fourths as much as the basic truck.

3.7.3 Designation of Loadings

The policy of affixing the year to loadings to identify them was instituted with the publication of the 1944 edition in the following manner:

- H 15 Loading, 1944 Edition shall be designated H 15-44
H 20 Loading, 1944 Edition shall be designated H 20-44
H 15-S 12 Loading, 1944 Edition shall be designated HS 15-44
H 20-S 16 Loading, 1944 Edition shall be designated HS 20-44

The affix shall remain unchanged until such time as the loading specification is revised. The same policy for identification shall be applied, for future reference, to loadings previously adopted by the American Association of State Highway and Transportation Officials.

3.7.4 Minimum Loading

Bridges shall be designed for HS 20-44 loading or an Alternate Military Loading of two axles four feet apart with each axle weighing 24,000 pounds, whichever produces the greatest stress.

Transverse Reinforced Slabs shall be designed with a single 32k axle.

3.7.5 H Loading

The H loadings consist of a two-axle truck or the corresponding lane loading as illustrated in Figures 3.7.6A and 3.7.6B. The H loadings are designated H followed by a number indicating the gross weight in tons of the standard truck.

3.7.6 HS Loading

The HS loadings consist of a tractor truck with semi-trailer or the corresponding lane load as illustrated in Figures 3.7.7A and 3.7.6B. The HS loadings are designated by the letters HS followed by a number indicating the gross weight in tons of the tractor truck. The variable axle spacing has been introduced in order that the spacing of axles may approximate more closely the tractor trailers now in use. The variable spacing also provides a more

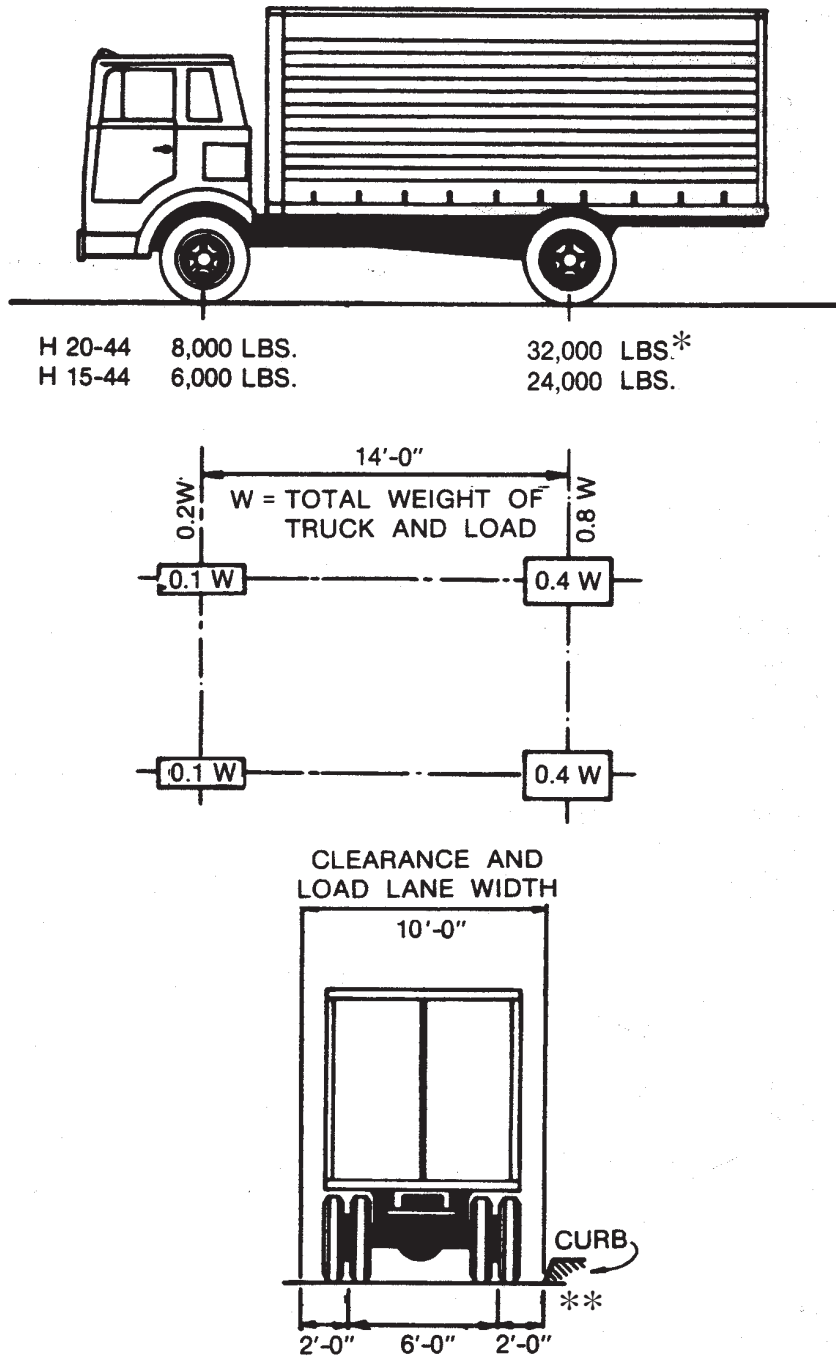

FIGURE 3.7.6A Standard H Trucks

* In the design of timber floors and orthotropic steel decks (excluding transverse beams) for H 20 loading, one axle load of 24,000 pounds or two axle loads of 16,000 pounds each spaced 4 feet apart may be used, whichever produces the greater stress, instead of the 32,000-pound axle shown.

** For slab design, the center line of wheels shall be assumed to be 1 foot from face of curb. (See Article 3.24.2)

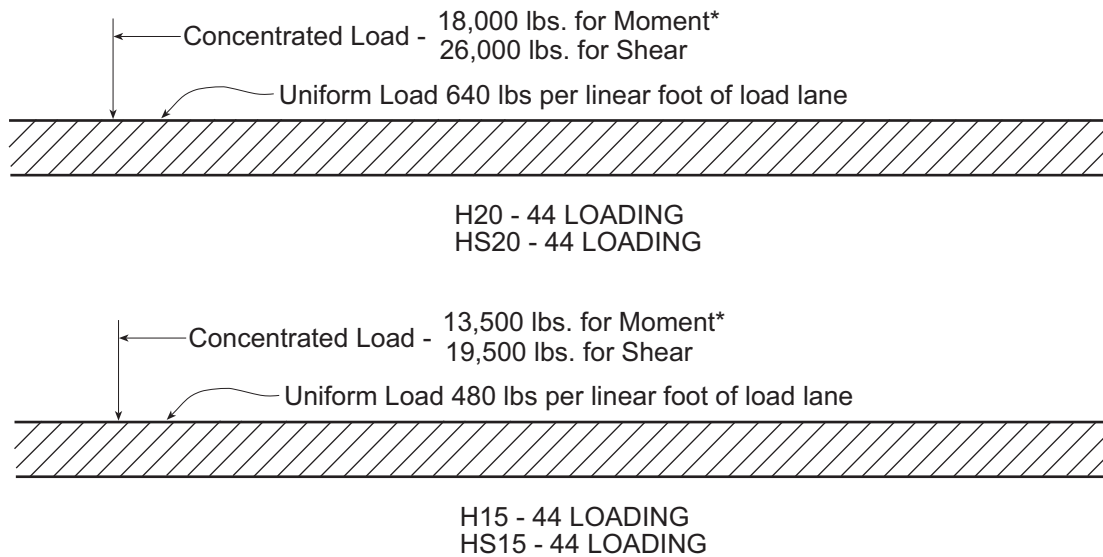

FIGURE 3.7.6B Lane Loading

* For the loading of continuous spans involving lane loading refer to Article 3.11.3 which provides for an additional concentrated load.

satisfactory loading for continuous spans, in that heavy axle loads may be so placed on adjoining spans as to produce maximum negative moments.

+ **3.7.7 P Loading**

+ P loads (permit design live loads) are special vehicular loads that shall be applied at the factored level in Load Factor Design and at service level for fatigue considerations in steel structures. See Figure 3.7.7B.

3.8 IMPACT

3.8.1 Application

Highway live loads shall be increased for those structural elements in Group A, below, to allow for dynamic, vibratory and impact effects. Impact allowances shall not be applied to items in Group B. It is intended that impact be included as part of the loads transferred from superstructure to substructure, but shall not be included in

loads transferred to footings nor to those parts of piles or columns that are below ground.

3.8.1.1 Group A-Impact Shall be Included

- (1) Superstructure, including legs of rigid frames.
- (2) Piers, (with or without bearings regardless of type) excluding footings and those portions below the ground line.
- (3) The portions above the ground line of concrete or steel piles that support the superstructure.

3.8.1.2 Group B-Impact Shall Not be Included

- (1) Abutments, retaining walls, piers, piles, except as specified in 3.8.1.1 (3).
- (2) Foundation pressures and footings.
- (3) Timber structures.
- (4) Sidewalk loads.
- (5) Culverts and structures having 3 feet or more cover.

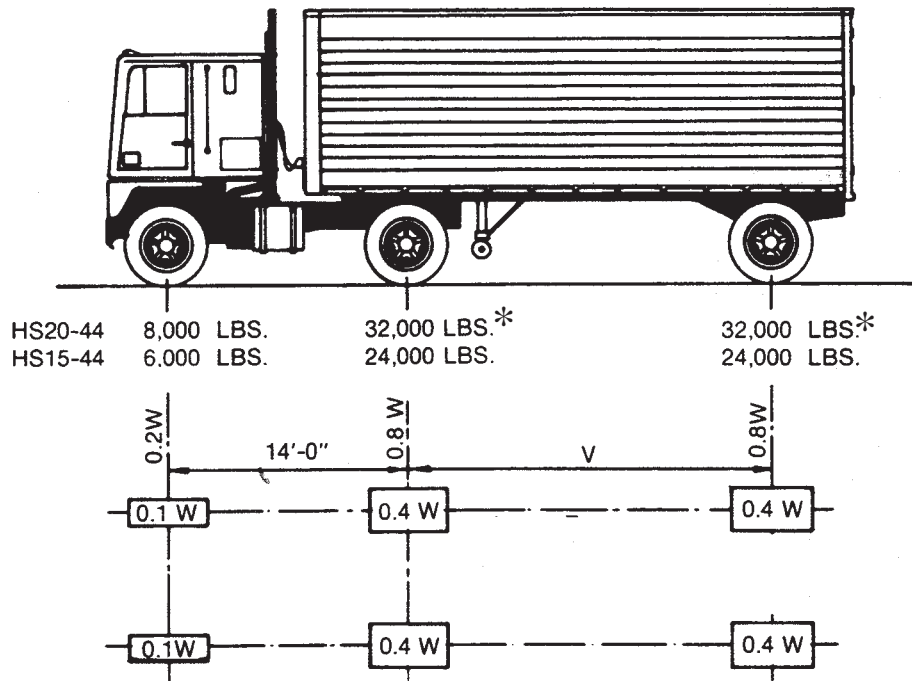

W = COMBINED WEIGHT ON THE FIRST TWO AXLES WHICH IS THE SAME AS FOR THE CORRESPONDING H TRUCK.
V = VARIABLE SPACING — 14 FEET TO 30 FEET INCLUSIVE. SPACING TO BE USED IS THAT WHICH PRODUCES MAXIMUM STRESSES.

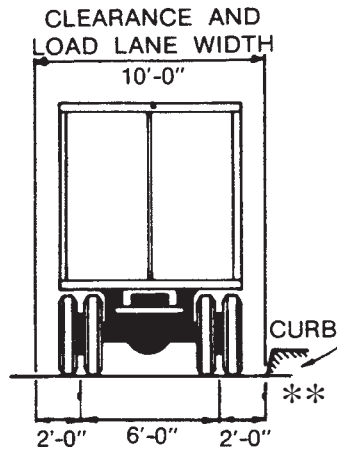
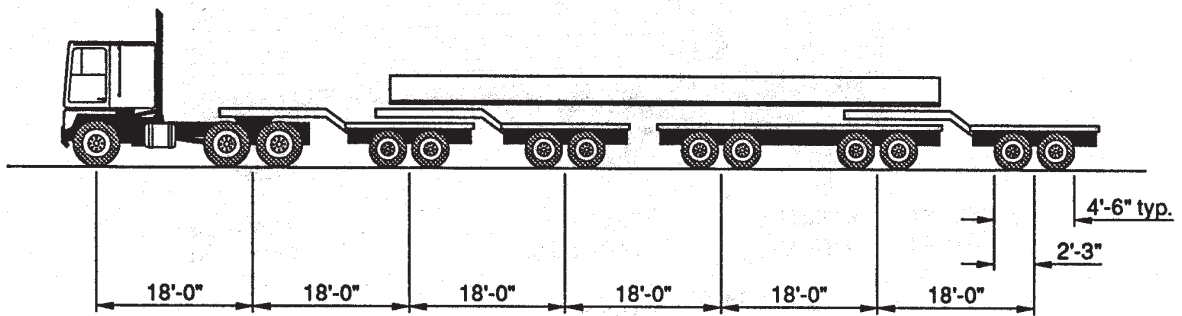

FIGURE 3.7.7A Standard HS Trucks

* In the design of timber floors and orthotropic steel decks (excluding transverse beams) for H 20 loading, one axle load of 24,000 pounds or two axle loads of 16,000 pounds each spaced 4 feet apart may be used, whichever produces the greater stress, instead of the 32,000-pound axle shown.

** For slab design, the center line of wheels shall be assumed to be 1 foot from face of curb. (See Article 3.24.2)



P5	26K	48K	48K	—	—	—	—	Min. Veh.
P7	26K	48K	48K	48K	—	—	—	
P9	26K	48K	48K	48K	48K	—	—	
P11	26K	48K	48K	48K	48K	48K	—	
P13	26K	48K	48K	48K	48K	48K	48K	Max. Veh.

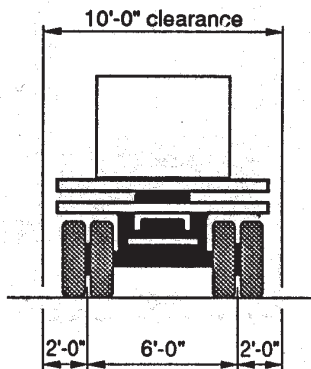
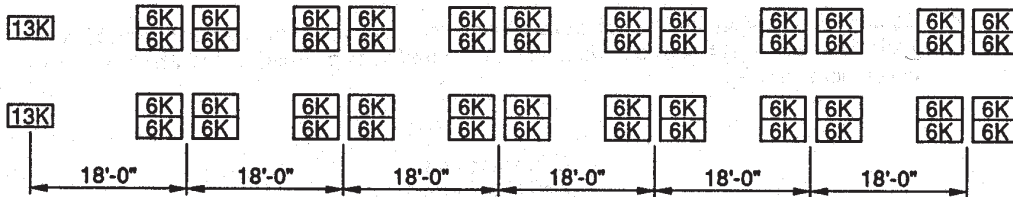

FIGURE 3.7.7B Permit Design Live Loads

3.8.2 Impact Formula

3.8.2.1 The amount of the impact allowance or increment is expressed as a fraction of the live load stress, and shall be determined by the formula:

$$I = \frac{50}{L+125} \quad (3-1)$$

in which,

- I = impact fraction (maximum 30 percent);
- L = length in feet of the portion of the span that is loaded to produce the maximum stress in the member as defined in 3.8.2.2..

3.8.2.2 For uniformity of application, in this formula, the loaded length, L, shall be as follows:

- (a) For roadway floors: The design span length.
- (b) For transverse members, such as floor beams: the span length of member center to center of supports.
- (c) For computing truck load moments: the span length, or for cantilever arms the length from the moment center to the farthest axle.
- (d) For shear due to truck loads: the length of the loaded portion of span from the point under consideration to the far reaction. For cantilever arms use a 30 percent impact factor.
- (e) For continuous spans: the length of span under consideration for positive moment, and the average of two adjacent loaded spans for negative moment and reaction.
- (f) For culverts and other underground structures with cover of less than three feet use an impact fraction of 0.30.

3.8.2.3 *For Culverts See "SECTION 6 - CULVERTS".*

3.9 LONGITUDINAL FORCES

3.9.1 Provision shall be made for the effect of a longitudinal force of 5 percent of the live load in all lanes carrying traffic headed in the same direction. All lanes shall be loaded for bridges likely to become one

directional in the future. The load used, without impact, shall be the lane load plus the concentrated load for moment specified in Article 3.7, with reduction for multiple-loaded lanes as specified in Article 3.12. The center of gravity of the longitudinal force shall be assumed to be located 6 feet above the floor slab and to be transmitted to the substructure through the superstructure.

3.10 CENTRIFUGAL FORCES

3.10.1 Structures on curves shall be designed for a horizontal radial force equal to the following percentage of the live load, without impact, in all traffic lanes:

$$C = 0.00117S^2D = \frac{6.68S^2}{R} \quad (3-2)$$

where,

- C = the centrifugal force in percent of the live load, without impact;
- S = the design speed in miles per hour;
- D = the degree of curve;
- R = the radius of the curve in feet.

3.10.2 The effects of superelevation shall be taken into account.

3.10.3 The centrifugal force shall be applied 6 feet above the roadway surface, measured along the centerline of the roadway. The design speed shall be determined with regard to the amount of superelevation provided in the roadway. The traffic lanes shall be loaded in accordance with the provisions of Article 3.7.

3.10.4 The loads and the number and positions of lanes loaded for centrifugal force shall be the same as for live load in the case under consideration. Design speed for P loads shall be 25 mph (max.).

3.10.5 When a reinforced concrete floor slab or a steel grid deck is keyed to or attached to its supporting members, it may be assumed that the deck resists, within its plane, the shear resulting from the centrifugal forces acting on the live load.



3.11 APPLICATION OF LIVE LOAD

3.11.1 Traffic Lane Units

In computing stresses, each 10-foot lane load or single standard truck shall be considered as a unit, and fractions of load lane widths or trucks shall not be used.

3.11.2 Number and Position of Traffic Lane Units

The number and position of the lane load or truck loads shall be as specified in Article 3.7 and, whether lane or truck loads, shall be such as to produce maximum stress, subject to the reduction specified in Article 3.12.

3.11.3 Lane Loads on Continuous Spans

For the determination of maximum negative moment in the design of continuous spans, the lane load shown in Figure 3.7.6B shall be modified by the addition of a second, equal weight concentrated load placed in one other span in the series in such position to produce the maximum effect. For maximum positive moment, only one concentrated load shall be used per lane, combined with as many spans loaded uniformly as are required to produce maximum moment.

3.11.4 Loading for Maximum Stress

3.11.4.1 On both simple and continuous spans, the type of loading, whether lane load or truck load, to be used shall be the loading which produces the maximum stress. The moment and shear tables given in Appendix A show which type of loading controls for simple spans.

3.11.4.2 For continuous spans, the lane loading shall be continuous or discontinuous; only one standard H or HS truck per lane shall be considered on the structure.

3.11.4.3 Loading for Load Factor Design

Apply H, HS, and Alternate Military Loadings, interchangeably, one per lane, for both strength and serviceability considerations in all materials.

Apply P loads for strength considerations only in all materials, and for serviceability under fatigue in structural steel. In Load Combination I_{pc}, distribution follows the same rules as Load Combination I_H. In Load Combination I_{pw}, the P load shall be used alone or in conjunction with one HS or Alternate Military Loading in a separate traffic lane depending upon which is most severe.

3.12 REDUCTION IN LOAD INTENSITY

3.12.1 Where maximum stresses are produced in any member by loading a number of traffic lanes simultaneously, the following percentages of the live loads shall be used in view of the improbability of coincident maximum loading:

	Percent
One or two lanes	100
Three lanes	90
Four lanes or more	75

3.12.2 The reduction in intensity of loads on transverse members such as floor beams shall be determined as in the case of main trusses or girders, using the number of traffic lanes across the width of roadway that must be loaded to produce maximum stresses in the floor beam.

3.13 ELECTRIC RAILWAY LOADS

If highway bridges carry electric railway traffic, the railway loads shall be determined from the class of traffic which the bridge may be expected to carry. The possibility that the bridge may be required to carry railroad freight cars shall be given consideration.

3.14 SIDEWALK, CURB, AND RAILING LOADING

3.14.1 Sidewalk Loading

3.14.1.1 Sidewalk floors, stringers and their immediate supports, shall be designed for a live load of 85 pounds per square foot of sidewalk area. Girders, trusses, arches and other members shall be designed for the following sidewalk live loads:



Spans 0 to 25 feet in length85 lb./ft.2
 Spans 26 to 100 feet in length60 lb./ft.2
 Spans over 100 feet in length according to the formula

$$P = \left(30 + \frac{3,000}{L} \right) \left(\frac{55 - W}{50} \right) \quad (3-3)$$

in which,

P = live load per square foot, max. 60-lb. per sq. ft.;
 L = loaded length of sidewalk in feet;
 W = width of sidewalk in feet.

3.14.1.2 In calculating stresses in structures that support cantilevered sidewalks, the sidewalk shall be fully loaded on only one side of the structure if this condition produces maximum stress.

+ **3.14.1.3** Bridges for pedestrian, equestrian and/
 + or bicycle traffic shall be designed for a live load of 85
 + PSF. Check equestrian bridge for $0.5(H20) = (H10)$
 + loading.

3.14.1.4 Where bicycle or pedestrian bridges are expected to be used by maintenance vehicles, special design consideration should be made for these loads. The following loads shall be used:

- + Clear deck width from 6 ft to 10 ft:
- + $0.25(H20) = (H5)$ loading
- + Clear deck width over 10 ft:
- + $0.5(H20) = (H10)$
- + Clear deck widths of less than 6 ft:
- + need not be designed for a maintenance vehicle
- + load.

+ In all cases, a single truck shall be positioned to
 + produce the maximum load effect. The maintenance
 + vehicle live load shall not be placed in combination with
 + the pedestrian live load.

+ **3.14.1.5** The frequency of pedestrian footfall
 + loads in either the vertical or lateral direction shall not
 + resonate with the natural frequencies of the structure. The
 + fundamental frequency shall be a minimum of 3 Hz in the
 + vertical direction and 1.3 Hz in the lateral direction,
 + unless detailed analysis justifies otherwise.

3.14.2 Curb Loading

3.14.2.1 Curbs shall be designed to resist a lateral force of not less than 500 pounds per linear foot of curb, applied at the top of the curb, or at an elevation 10 inches above the floor if the curb is higher than 10 inches.

3.14.2.2 Where sidewalk, curb, and traffic rail form an integral system, the traffic railing loading shall be applied and stresses in curbs computed accordingly.

3.14.3 Railing Loading

For Railing Loads, see Article 2.7.

3.15 WIND LOADS

The wind load shall consist of moving uniformly distributed loads applied to the exposed area of the structure. The exposed area shall be the sum of the areas of all members, including floor system and railing, as seen in elevation at 90 degrees to the longitudinal axis of the structure. The forces and loads given herein are for a base wind velocity of 100 mile per hour. For Group II and Group V loading, but not for Group III and Group VI loadings, they may be reduced or increased in the ratio of the square of the design wind velocity to the square of the base wind velocity provided that the maximum probable wind velocity can be ascertained with reasonable accuracy, or provided that there are permanent features of the terrain which make such changes safe and advisable. If a change in the design wind velocity is made, the design wind velocity shall be shown on the plans.

3.15.1 Superstructure Design

3.15.1.1 Group II and Group V Loadings

3.15.1.1.1 A wind load of the following intensity shall be applied horizontally at right angles to the longitudinal axis of the structure:

For trusses and arches 75 pounds per square foot
 For girders and beams 50 pounds per square foot



3.15.1.1.2 The total force shall not be less than 300 pounds per linear foot in the plane of the windward chord and 150 pounds per linear foot in the plane of the leeward chord on truss spans, and not less than 300 pounds per linear foot on girder spans.

3.15.1.2 Group III and Group VI Loadings

Group III and Group VI loadings shall comprise the loads used for Group II and Group V loadings reduced by 70 percent and a load of 100 pounds per linear foot applied at right angles to the longitudinal axis of the structure and 6 feet above the deck as a wind load on a moving live load. When a reinforced concrete floor slab or a steel grid deck is keyed to or attached to its supporting members, it may be assumed that the deck resists, within its plane, the shear resulting from the wind load on the moving live load.

3.15.2 Substructure Design

Forces transmitted to the substructure by the superstructure and forces applied directly to the substructure by wind loads shall be as follows:

3.15.2.1 Forces from Superstructure

3.15.2.1.1 For unusual or major structures the transverse and longitudinal forces transmitted by the superstructure to the substructure for various angles of wind direction shall be as set forth in the following table. The skew angle is measured from the perpendicular to the longitudinal axis and the assumed wind direction shall be that which produces the maximum stress in the substructure. The transverse and longitudinal forces shall be applied simultaneously at the elevation of the center of gravity of the exposed area of the superstructure.

Skew Angle of Wind Degrees	Trusses		Girders	
	Lateral Load	Longitudinal Load	Lateral Load	Longitudinal Load
	PSF	PSF	PSF	PSF
0	75	0	50	0
15	70	12	44	6
30	65	28	41	12
45	47	41	33	16
60	24	50	17	19

The loads listed above shall be used in Group II and Group V loading as given in Article 3.22.

3.15.2.1.2 For Group III and Group VI loadings, the loads may be reduced by 70 percent and a load per linear foot added as a wind load on a moving live load, as given in the following table:

Skew Angle of Wind Degrees	Lateral Load	Longitudinal Load
	lb./ft.	lb./ft.
0	100	0
15	88	12
30	82	24
45	66	32
60	34	38

This load shall be applied at a point 6 feet above the deck.

3.15.2.1.3 For the usual girder and slab bridges the following wind loading may be used.

W (wind load on structure)
50 pounds per square foot, transverse;
12 pounds per square foot, longitudinal;
Both forces shall be applied simultaneously.

WL (wind load on live load)
100 pounds per linear foot, transverse;
40 pounds per linear foot, longitudinal;
Both forces shall be applied simultaneously.

3.15.2.2 Forces Applied Directly to the Substructure

The transverse and longitudinal forces to be applied directly to the substructure for a 100-mile per hour wind shall be calculated from an assumed wind force of 40 pounds per square foot. For wind directions assumed skewed to the substructure this force shall be resolved into components perpendicular to the end and front elevations of the substructure. The component perpendicular to the end elevation shall act on the exposed substructure area as seen in end elevation and the component perpendicular to the front elevation shall act on the exposed areas and shall be applied simultaneously with the wind loads from the superstructure. The above loads are for Group II and Group V loadings and may be reduced by 70 percent for Group III and Group VI loadings, as indicated in Article 3.22.



3.15.3 Overturning Forces

The effect of forces tending to overturn structures shall be calculated under Groups II, III, V, and VI of Article 3.22 assuming that the wind direction is at right angles to the longitudinal axis of the structure. In addition, an upward force shall be applied at the windward quarter point of the transverse superstructure width. This force shall be 20 pounds per square foot of deck and sidewalk plan area for Group II and group V combinations and 6 pounds per square foot for Group III and Group VI combinations.

3.16 THERMAL FORCES

Provisions shall be made for stresses or movements resulting from variations in temperature. The rise and fall in temperature shall be fixed for the locality in which the structure is to be constructed and shall be computed from an assumed temperature at the time of erection. Due consideration shall be given to the lag between air temperature and the interior temperature of massive concrete members or structures.

+ The range of temperature shall generally be as follows:

Air Temperature Range	Design Range	
	Steel	Concrete
Extreme: 120° F Certain mountain and desert locations	Rise or Fall 60° F Movement/Unit Length .00039	Rise or Fall 40° F Movement/Unit Length .00024
Moderate: 100° F Interior Valleys and most mountain locations	Rise or Fall 50° F Movement/Unit Length .00033	Rise or Fall 35° F Movement/Unit Length .00021
Mild: 80° F Coastal Areas, Los Angeles, and San Francisco Bay Area	Rise or Fall 40° F Movement/Unit Length .00026	Rise or Fall 30° F Movement/Unit Length .00018

+ Provisions shall be made in concrete structures for stresses and movements resulting from shrinkage, as follows:

+ Arches - Shrinkage Coefficient 0.0002

Prestressed Structures - See Division 1, Section 9 of this volume. +

Other Structures - The temperature fall from a normal temperature as given above provides adequately for stress and movement caused by shrinkage. +

3.17 UPLIFT

3.17.1 Provision shall be made for adequate attachment of the superstructure to the substructure by ensuring that the calculated uplift at any support is resisted by tension members engaging a mass of masonry equal to the largest force obtained under one of the following conditions: +

- (a) 100 percent of the calculated uplift caused by any loading or combination of loadings in which the live plus impact loading is increased by 100 percent.
- (b) 150 percent of the calculated uplift at working load level.
- (c) 100 percent of the calculated uplift for load factor design.

3.17.2 Anchor bolts subject to tension or other elements of the structures stressed under the above conditions shall be designed at 150 percent of the allowable basic stress.

3.18 FORCE FROM STREAM CURRENT, FLOATING ICE AND DRIFT

All piers and other portion so structures that are subject to the force of flowing water, floating ice, or drift shall be designed to resist the maximum stresses induced thereby.

3.18.1 Force of Stream Current on Piers

3.18.1.1 Stream Pressure

3.18.1.1.1 The effect of flowing water on piers and drift build-up, assuming a second degree parabolic velocity distribution and thus a triangular pressure distribution, shall be calculated by the formula:

$$P_{avg} = K(V_{avg})^2 \quad (3-4)$$

where:

- P_{avg} = average steam pressure, in pounds per square foot;
- V_{avg} = average velocity of water in feet per second; computed by dividing the flow rate by the flow area,
- K = a constant, being 1.4 for all piers subjected to drift build-up and square-ended piers, 0.7 for circular piers, and 0.5 for angle-ended piers where the angle is 30 degrees or less.

The maximum stream flow pressure, P_{max} , shall be equal to twice the average stream flow pressure, P_{avg} , computed by Equation 3-4. Stream flow pressure shall be a triangular distribution with P_{max} located at the top of water elevation and a zero pressure located at the flow line.

3.18.1.1.2 The stream flow forces shall be computed by the product of the stream flow pressure, taking into account the pressure distribution, and the exposed pier area. In cases where the corresponding top of water elevation is above the low beam elevation, stream flow loading on the superstructure shall be investigated. The stream flow pressure acting on the superstructure may be taken as P_{max} with a uniform distribution.

3.18.1.2 Pressure Components

When the direction of stream flow is other than normal to the exposed surface area, or when bank migration or a change of stream bed meander is anticipated, the effects of the directional components of stream flow pressure shall be investigated.

3.18.1.3 Drift Lodged Against Pier

Where a significant amount of drift lodged against a pier is anticipated, the effects of this drift buildup shall be considered in the design of the bridge opening and the bridge components. The overall dimensions of the drift buildup shall reflect the selected pier locations, site conditions, and known drift supply upstream. When it is anticipated that the flow area will be significantly blocked by drift buildup, increases in high water elevations, stream velocities, stream flow pressures, and the potential increases in scour depths shall be investigated.

3.18.2 Force of Ice on Piers

Pressure of ice on piers shall be calculated at 400 pounds per square inch. The thickness of ice and height at which it applies shall be determined by investigation at the site of the structure.

3.19 BUOYANCY

Buoyancy shall be considered where it affects the design of either substructure, including piling, or the superstructure.

3.20 EARTH PRESSURE

3.20.1 Structures which retain level fills shall be proportioned to withstand pressure as given by Rankine's formula, or by other expressions given in Section 5, "Retaining Walls"; provided, however, that no vertical wall structure shall be designed for less than an equivalent fluid unit weight of 36 pounds per cubic foot, except that the maximum load on the heels of wall footings shall be determined by using an equivalent fluid unit weight of 27 pounds per cubic foot.

3.20.2 For rigid frames a maximum of one-half of the moment caused by earth pressure (lateral) may be used to reduce the positive moment in the beams, in the top slab, or in the top and bottom slab, as the case may be.

3.20.3 When highway traffic can come within a horizontal distance from the top of the structure equal to one-half its height, the pressure shall have added to it a live load surcharge pressure equal to not less than 2 feet of the earth.

3.20.4 Where an adequately designed reinforced concrete approach slab supported at one end by the bridge is provided, no live load surcharge need be considered.

3.20.5 All designs shall provide for the thorough drainage of the back-filling material by means of weep holes and crushed rock, pipe drains or gravel drains, or by perforated drains.



3.21 EARTHQUAKES

- + All structures shall be designed to resist earthquake
- + motions by considering the relationship of the site to
- + active faults, the seismic response of the soils at the site,
- + and the dynamic response characteristics of the total
- + structure and its individual components in accordance
- + with the Caltrans Seismic Design Criteria.

**Part B
Combinations of Loads**

3.22 COMBINATIONS OF LOADS

3.22.1 The following Groups represent various combination of loads and forces to which a structure may be subjected. Each component of the structure, or the foundation on which it rests, shall be proportioned to withstand safely all group combinations of these forces that are applicable to the particular site or type. Group loading combinations for Service Load Design and Load Factor Design are given by:

$$\text{Group (N)} = \gamma[\beta_D D + \beta_L (L + I) + \beta_C CF + \beta_E E + \beta_B B + \beta_S SF + \beta_W W + \beta_{PS} PS + \beta_{WL} WL + \beta_L LF + \beta_R (R + S + T) + \beta_{EQ} EQ + \beta_{ICE} ICE + \beta_{CT} CT] \quad (3-10)$$

where

- N = group number;
- γ = load factor, see Table 3.22.1A and B;
- β = coefficient, see Table 3.22.1A and B;
- D = dead load;
- L = live load;
- I = live load impact;
- E = earth pressure;
- B = buoyancy;
- W = wind load on structure;
- WL = wind load on live load-100 pounds per linear foot;
- LF = longitudinal force from live load;
- CF = centrifugal force;
- R = rib shortening;
- S = shrinkage;
- T = temperature;
- EQ = earthquake;
- SF = stream flow pressure;
- ICE = ice pressure;
- PS = prestress.
- CT = truck collision

3.22.2 For service load design, the percentage of the basic unit stress for the various groups is given in Table 3.22.1B.

The loads and forces in each group shall be taken as appropriate from Articles 3.3 to 3.21. The maximum section required shall be used.

TABLE 3.22.1A Factors for Load Factor Design

Group	Gamma Factor	Beta Factors														
		D	(L+I)H	(L+I)P	CF	E	B	SF	W	WL	LF	PS	R+S+T	EQ	ICE	CT
I _H	1.30	βD	1.67	0	1	βE	1	1	0	0	0	0.77	0	0	0	0
I _{PC}	1.30	βD	0	1	1	βE	1	1	0	0	0	0.77	0	0	0	0
I _{PW}	1.30	βD	1	1.15	1	βE	1	1	0	0	0	0.77	0	0	0	0
I _{P3D}	1.30	βD	1	1.25	1	βE	1	1	0	0	0	0.77	0	0	0	0
II	1.30	βD	0	0	0	βE	1	1	1	0	0	0.77	0	0	0	0
III	1.30	βD	1	0	1	βE	1	1	0.3	1	1	0.77	0	0	0	0
IV	1.30	βD	1	0	1	βE	1	1	0	0	0	0.77	1	0	0	0
V	1.25	βD	0	0	0	βE	1	1	1	0	0	0.80	1	0	0	0
VI	1.25	βD	1	0	1	βE	1	1	0.3	1	1	0.80	1	0	0	0
VII	1.00	1	0	0	0	βE	1	1	0	0	0	1.00	0	1	0	0
VIII	1.30	βD	1	0	1	βE	1	1	0	0	0	0.77	0	0	1	0
IX	1.20	βD	0	0	0	βE	1	1	1	0	0	0.83	0	0	1	0
X*	1.30	βD	1.67	0	0	βE	0	0	0	0	0	0.67	0	0	0	0
XI	1.0	1.0	0.5	0	0	βE	0	0	0	0	0	1.0	0	0	0	1

H denotes H loads.

PC denotes P loads on closely spaced girders used only for superstructures.

PW denotes P loads on widely spaced girders and substructures.

P3D denotes P loads only on superstructures when three-dimensional analysis is used for load distribution.

βD = 0.75 when checking columns for maximum moment or maximum eccentricities and associated axial load; and when Dead Load effects are of opposite sign to the net effects of other loads in a Group.

βD = 1.00 when checking columns for maximum axial load and associated moment.

βD = 1.00 for flexural and tension members and for culverts.

βE = 0.50 for checking positive moments in rigid frames.

βE = 1.00 for vertical earth pressure and for rigid culverts.

βE = 1.30 for lateral earth pressure. (Not for culverts.)

βE = 1.50 for flexible culverts.

* Group X applies only to culverts. Other Groups do not apply to culverts.



TABLE 3.22.1B Factors for Service Load Design*

Group	Gamma Factor	Beta Factors												
		D	L+I	CF	E	B	SF	W	WL	LF	P _s	R+S+T	ICE	%
I	1.0	1	1	1	1	1	1	0	0	0	1	0	0	100
II	1.0	1	0	0	1	1	1	1	0	0	1	0	0	125
III	1.0	1	1	1	1	1	1	0.3	1	1	1	0	0	125
IV	1.0	1	1	1	1	1	1	0	0	0	1	1	0	125
V	1.0	1	0	0	1	1	1	1	0	0	1	1	0	140
VI	1.0	1	1	1	1	1	1	0.3	1	1	1	1	0	140
VIII	1.0	1	1	1	1	1	1	0	0	0	1	0	1	140
IX	1.0	1	0	0	1	1	1	1	0	0	1	0	1	150

* Not applicable for culvert design. Use Load Factor Design.

% Indicates percentage of basic unit stress.

No increase in allowable unit stresses shall be permitted for members or connections carrying wind loads only

P Loads apply in Service Load design only for checking serviceability under fatigue in structural steel.

When EQ loads are applied, Load Factor Design shall be used to analyze their effects.

+
+
+
+
+
+
+
+
+
+
+
+
+
+
+
+
+
+
+
+
+
+
+
+
+
+
+
+
+
+
+
+
+
+
+
+
+
+

+ **3.22.3** For load factor design, the gamma and beta factors given in Table 3.22.1A are only intended for designing structural members by the load factor concept. The load factors are not intended to be used when checking the foundation stability (safety factors against overturning, sliding, etc.) of a structure.

3.22.4 When long span structures are being designed by load factor design, the gamma and beta factors specified for Load Factor Design represent general conditions and should be increased if, in the Engineer's judgment, expected loads, service conditions, or materials of construction are different from those anticipated by the specifications.

+ **3.22.5** At the factored level all structures shall be analyzed for the effect of both HS and P Loads as defined in Article 3.7 using the group loading combinations of Table 3.22.1A. P Loads shall be considered as follows:

+ Group I_{PC} applies only for P Load application to superstructures for which Footnote f to Table 3.23.1 does not apply. The distribution follows the same rules as applies to H Loads, Article 3.23.

+ Group I_{PW} applies for P Load application for which Footnote f to Table 3.23.1 applies. Group I_{PW} also applies to all substructures including bents and pier caps entirely contained within the superstructure. Load combination I_{PW} is to be applied in accordance with Article 3.11.

+ Group I_{P3D} applies only for P load application to superstructures for which a three dimensional analysis for live loads has been conducted that explicitly considers the lateral stiffness and load transfer characteristics of the superstructure elements. Load combination I_{P3D} is to be applied in accordance with Article 3.11.

+ **3.22.6** Load factor design methods of AASHTO using Load Group IB shall be used for the analysis of specific loads that do not conform to any design loading specified herein. Distribution of such loads shall be consistent with the nature of the load and provisions of these specifications.

Part C Distribution of Loads

3.23 DISTRIBUTION OF LOADS TO STRINGERS, LONGITUDINAL BEAMS, AND FLOOR BEAMS*

3.23.1 Position of Loads for Shear

3.23.1.1 In calculating end shears and end reactions in transverse floor beams and longitudinal beams and stringers, no longitudinal distribution of the wheel load shall be assumed for the wheel or axle load adjacent to the end at which the stress is being determined.

3.23.1.2 Lateral distribution of the wheel load shall be that produced by assuming the flooring to act as a simple span between stringers or beams. For loads in other positions on the span, the distribution for shear shall be determined by the method prescribed for moment, except that the calculations of horizontal shear in rectangular timber beams shall be in accordance with Article 13.3.

3.23.2 Bending Moments in Stringers and Longitudinal Beams**

3.23.2.1 General

In calculating bending moments in longitudinal beams or stringers, no longitudinal distribution of the wheel loads shall be assumed. The lateral distribution shall be determined as follows.

3.23.2.2 Interior Stringers and Beams

The live load bending moment for each interior stringer shall be determined by applying to the stringer

* Provisions in this Article shall not apply to orthotropic deck bridges.

** In view of the complexity of the theoretical analysis involved in the distribution of wheel loads to stringers, the empirical method herein described is authorized for the design of normal highway bridges.



the fraction of a wheel load (both front and rear) determined in Table 3.23.1.

+ 3.23.2.2.1 The dead load bending moments for each interior stringer shall be determined by applying the panel load to the stringer. Box girders designed as whole-width units shall have the dead load applied uniformly to the whole cross-section.

+ 3.23.2.2.2 Curbs, sidewalks, railings, and wearing surface may be considered equally distributed to all roadway stringers or beams, but shall not be distributed beyond a longitudinal expansion joint in the roadway slab.

+ 3.23.2.2.3 The weight of each utility to be carried on a structure shall be distributed to supporting longitudinal members assuming a simple beam between longitudinal members.

3.23.2.3 Outside Roadway Stringers and Beams

3.23.2.3.1 Steel-Timber-Concrete T-Beams

3.23.2.3.1.1 The dead load supported by the outside roadway stringer or beam shall be that portion of the floor slab carried by the stringer or beam. Curbs, railings, and wearing surface, if placed after the slab has cured, may be distributed equally to all roadway stringers or beams.

+ 3.23.2.3.1.2 The live load bending moment for outside roadway stringers or beams shall be determined by applying to the stringer or beam the fraction of a wheel line determined by multiplying the value of the interior stringers or beams by

+
$$W_e/S$$

+ W_e = The top slab width as measured from the outside face of the slab to the midpoint between the exterior and interior stringer or beam. The cantilever dimension of any slab extending beyond the exterior girder shall not exceed $S/2$, measured from the centerline of the exterior beam.

+ S = average stringer spacing in feet. If S exceeds values given in Table 3.23.1 use footnote f.

3.23.2.3.1.3 When the outside roadway beam or stringer supports the sidewalk live load as well as traffic live load and impact and the structure is to be designed by the service load method, the allowable stress in the beam or stringer may be increased by 25 percent for the combination of dead load, sidewalk live load, traffic live load, and impact, providing the beam is of no less carrying capacity than would be required if there were no sidewalks. When the combination of sidewalk live load and traffic live load plus impact governs the design and the structure is to be designed by the load factor method, 1.25 may be used as the beta factor in place of 1.67.

3.23.2.3.1.4 In no case shall an exterior stringer have less carrying capacity than an interior stringer.

3.23.2.3.1.5 Deleted +

3.23.2.3.2 Concrete Box Girders

Dead load and live load distribution to exterior girders shall be included in whole-width unit designs as given in Article 3.23.2.2. +

3.23.2.3.3 Total Capacity of Stringers and Beams

The combined design load capacity of all the beams and stringers in a span shall not be less than required to support the total live and dead load in the span.

3.23.3 Bending Moments in Floor Beams (Transverse)

3.23.3.1 In calculating bending moments in floor beams, no transverse distribution of the wheel loads shall be assumed.

3.23.3.2 If longitudinal stringers are omitted and the floor is supported directly on floor beams, the beams shall be designed for loads determined in accordance with Table 3.23.3.1.

TABLE 3.23.1 Distribution of Wheel Loads in Longitudinal Beams

Kind of Floor	Bridge Designed for One Traffic Lane	Bridge Designed for Two or more Traffic Lanes
Timber ^a :		
Plank ^b	S/4.0	S/3.75
Nail laminated ^c 4" thick or multiple layer ^d floors over 5" thick	S/4.5	S/4.0
Nail laminated ^c 6" or more thick	S/5.0 If S exceeds 5' use footnote f.	S/4.25 If S exceeds 6.5' use footnote f.
Glued Laminated ^e Panels on glued Laminated Stringers		
4" thick	S/4.5	S/4.0
6" or more thick	S/6.0 If S exceeds 6' use footnote f.	S/5.0 If S exceeds 7.5' use footnote f.
On Steel Stringers		
4" thick	S/4.5	S/4.0
6" or more thick	S/5.25 If S exceeds 5.5' use footnote f.	S/4.5 If S exceeds 7' use footnote f.
Concrete:		
On Steel I-Beam Stringers ^g and Prestressed Concrete Girders	S/7.0 If S exceeds 10' use footnote f.	S/5.5 If S exceeds 14' use footnote f.
+ On Concrete + T-Beams ^k	S/6.5 If S exceeds 6' use footnote f.	S/6.0 If S exceeds 15' use footnote f.
On Timber Stringers	S/6.0 If S exceeds 6' use footnote f.	S/5.0 If S exceeds 10' use footnote f.
+ Concrete box girders ^{h,j} :		
+ Designed as whole width units.		<u>Overall deck width</u>
+ Do not apply Article 3.12.		7.0
On Steel Box Girders		See Article 10.39.2.
On Prestressed Concrete Spread Box Beams		See Article 3.28.
Steel Grid:		
(Less than 4" thick)	S/4.5	S/4.0
(4" or more)	S/6.0 If S exceeds 6' use footnote f.	S/5.0 If S exceeds 10.5' use footnote f.
Steel Bridge Corrugated Plank ⁱ (2" min. depth)	S/5.5	S/4.5

S = average stringer spacing in feet.

^aTimber dimensions shown are for nominal thickness.

^bPlank floors consist of pieces of lumber laid edge to edge with the wide faces bearing on the supports. (See Article 16.3.11-Division II).

^cNail laminated floors consist of pieces of lumber laid face to face with the narrow edges bearing on the supports, each piece being nailed to the preceding piece. (See Article 16.3.12-Division II).

^dMultiple layer floors consist of two or more layers of planks, each layer being laid at an angle to the other. (See Article 16.3.11-Division II).

^eGlued laminated panel floors consist of vertically glued laminated members with the narrow edges of the laminations bearing on the supports. (See Article 16.3.13-Division II).

^fIn this case the load on each stringer shall be the reaction of the wheel loads, assuming the flooring between the stringers to act as a simple beam.

^g"Design of I-Beam Bridges" by N. M. Newmark-Proceedings, ASCE, March 1948.

^hThe sidewalk live load (see Article 3.14) shall be omitted for interior and exterior box girders designed in accordance with the wheel load distribution indicated herein.

ⁱDistribution factors for Steel Bridge Corrugated Plank set forth above are based substantially on the following reference:

Journal of Washington Academy of Sciences, Vol. 67, No. 2, 1977
"Wheel Load Distribution of Steel Bridge Plank," by Conrad P. Heins, Professor of Civil Engineering, University of Maryland.

These distribution factors were developed based on studies using 6" x 2" steel corrugated plank. The factors should yield safe results for other corrugation configurations provided primary bending stiffness is the same as or greater than the 6" x 2" corrugated plank used in the studies.

^jUnusual plan layouts may be designed as individual girders, using S/7. If S exceeds 16' use footnote f.

^k"Design of Slab and Stringer Highway Bridges", by N.M. Newmark and C.P. Siess - Public Roads, January-February-March 1943. "Distribution of Loads to Girders in Slab-and-Girder Bridges; Theoretical Analyses and Their Relation to Field Tests" by C.P. Siess and A.S. Veletsos - Highway Research Board Report 14-B, 1952.

3.23.4 Precast Concrete Beams Used in Multi-Beam Decks

3.23.4.1 A multi-beam bridge is constructed with precast reinforced or prestressed concrete beams that are placed side by side on the supports. The interaction between the beams is developed by continuous longitudinal shear keys used in combination with transverse tie assemblies which may, or may not, be prestressed, such as bolts, rods, or prestressing strands, or other mechanical means. Full-depth rigid end diaphragms are needed to ensure proper load distribution for channel, single- and multi-stemmed tee beams.

TABLE 3.23.3.1 Distribution of Wheel Loads in Transverse Beams

Kind of Floor	Fraction of Wheel Load to Each Floor Beam
Plank ^{a,b}	$\frac{S}{4}$
Nail laminated ^c or glued laminated ^c , 4 inches in thickness, or multiple layer ^d floors more than 5 inches thick	$\frac{S}{4.5}$
Nail laminated ^c or glued laminated ^c , 6 inches or more in thickness	$\frac{S^f}{5}$
Concrete	$\frac{S^f}{6}$
Steel grid (less than 4 inches thick)	$\frac{S}{4.5}$
Steel grid (4 inches or more)	$\frac{S^f}{6}$
Steel bridge corrugated plank (2 inches minimum depth)	$\frac{S}{5.5}$

Note:

S = spacing of floor beams in feet.

^{a-c}For footnotes a through e, see Table 3.23.1.

^fIf S exceeds denominator, the load on the beam shall be the reaction of the wheels loads assuming the flooring between beams to act as a simple beam.

3.23.4.2 In calculating bending moments in multi-beam precast concrete bridges, conventional or prestressed, no longitudinal distribution of wheel load shall be assumed.

3.23.4.3 The live load bending moment for each section shall be determined by applying to the beam the fraction of a wheel load (both front and rear) determined by the following equation:

$$\text{Load Fraction} = \frac{S}{D} \quad (3-11)$$

where,

$$S = \text{width of precast member;} \\ D = (5.75 - 0.5N_L) + 0.7N_L (1 - 0.2C)^2 \quad \text{when } C \leq 5 \quad (3-12)$$

$$D = (5.75 - 0.5N_L) \quad \text{when } C > 5 \quad (3-13)$$

N_L = number of traffic lanes from Article 3.6;

$$C = K(W/L) \quad (3-14)$$

where,

W = overall width of bridge measured perpendicular to the longitudinal girders in feet;

L = span length measured parallel to longitudinal girders in feet; for girders with cast-in-place and diaphragms, use the length between end diaphragms;

$$K = \{(1 + \mu)I/J\}^{1/2}$$

If the value of $\sqrt{I/J}$ exceeds 5.0, the live load distribution should be determined using a more precise method, such as the Articulate Plate Theory or Grillage Analysis.

where,

I = moment of inertia;

J = Saint-Venant torsion constant;

μ = Poisson's ratio for girders.

In lieu of more exact methods, "J" may be estimated using the following equations:

For Non-voided Rectangular Beams, Channels, Tee Beams:

$$J = \sum \left\{ \left(\frac{1}{3} \right) b t^3 (1 - 0.630t/b) \right\}$$

where,

b = the length of each rectangular component within the section.

t = the thickness of each rectangular component within the section.

The flanges and stems of stemmed or channel sections are considered as separate rectangular components whose values are summed together to calculate "J". Note that for

"Rectangular Beams with Circular Voids" the value of "J" can usually be approximated by using the equation above for rectangular sections and neglecting the voids.

For Box-Section Beams:

$$J = \frac{2tt_f(b-t)^2(d-t_f)^2}{bt + dt_f - t^2 - t_f^2}$$

where

- b = the overall width of the box,
- d = the overall depth of the box,
- t = the thickness of either web,
- t_f = the thickness of either flange.

The formula assumes that both flanges are the same thickness and uses the thickness of only one flange. The same is true of the webs.

For preliminary design, the following values of K may be used.

Bridge Type	Beam Type	K
Multi-beam	Non-voided rectangular beams	0.7
	Rectangular beams with circular voids	0.8
	Box section beams	1.0
	Channel, single and multi-stemmed tee beams	2.2

3.24 DISTRIBUTION OF LOADS AND DESIGN OF CONCRETE SLABS*

3.24.1 Span Lengths (See Article 8.8)

3.24.1.1 For simple spans the span length shall be the distance center to center of supports but need not exceed clear span plus thickness of slab.

* The slab distribution set forth herein is based substantially on the "Westergaard" theory. The following references are furnished concerning the subject of slab design.

Public Roads, March 1930, "Computation of Stresses in Bridge Slabs Due to Wheel Loads," by H.M. Westergaard.

University of Illinois, Bulletin No. 303, "Solutions for Certain Rectangular Slabs Continuous over Flexible Supports," by Vernon P. Jensen; Bulletin 304, "A Distribution Procedure for the Analysis of Slabs Continuous over Flexible Beams," by Nathan M. Newmark; Bulletin 315, "Moments in Simple Span Bridge Slabs with Stiffened Edges," by Vernon P. Jensen; and Bulletin 346, "Highway Slab Bridges with Curbs; Laboratory Tests and Proposed Design Method."

3.24.1.2 The following effective span lengths shall be used in calculating the distribution of loads and bending moments for slabs continuous over more than two supports:

- (a) Slabs monolithic with beams or slabs monolithic with walls without haunches and rigid top flange prestressed beams with top flange width to minimum thickness ratio less than 4.0. "S" shall be the clear span.
- (b) Slabs supported on steel stringers, or slabs supported on thin top flange prestressed beams with top flange width to minimum thickness ratio equal to or greater than 4.0. "S" shall be the distance between edges of top flange plus one-half of stringer top flange width.
- (c) Slabs supported on timber stringers. "S" shall be the clear span plus one-half thickness of stringer.

3.24.2 Edge Distance of Wheel Loads

3.24.2.1 In designing sidewalks, supporting members, and slabs including cantilever overhangs, the center line of the wheel load shall be 1 foot from the face of the rail. However, a wheel load need not be applied on sidewalks protected by a vehicle barrier rail. (See Commentary)

3.24.2.2 In service load design, the combined permanent, pedestrian, vehicular and impact stresses for the loading described in 3.24.2.1 shall not be greater than 150 percent of the allowable stresses. In load factor design for combined permanent, pedestrian, vehicular, and impact loads, 1.0 may be used as the beta factor in place of 1.67 for the design of deck slabs.

3.24.3 Bending Moment

The bending moment per foot width of slab shall be calculated according to methods given under Cases A and B, unless more exact methods are used considering tire contact area. The tire contact area needed for exact methods is given in Article 3.30.

In Cases A and B:

- S = effective span length, in feet, as defined under "Span Lengths" Articles 3.24.1 and 8.8;



- E = width of slab in feet over which a wheel load is distributed;
- + P = load on one rear wheel of truck
- P₂₀ = 16,000 pounds for H 20 loading.

3.24.3.1 Case A-Main Reinforcement Perpendicular to Traffic (Spans 2 to 24 Feet Inclusive)

The live load moment for simple spans shall be determined by the following formula (impact not included):

HS 20 Loading:

$$\left(\frac{S+2}{32}\right) P_{20} = \text{Moments in foot - pounds}$$

In slabs continuous over three or more supports, a continuity factor of 0.8 shall be applied to the above formulas for both positive and negative moment.

3.24.3.2 Case B-Main Reinforcement Parallel to Traffic

For wheel loads, the distribution width, E, shall be (4+0.06S) but shall not exceed 7.0 feet. Lane loads are distributed over a width of 2E. Longitudinally reinforced slabs shall be designed for the appropriate live loading.

3.24.4 Shear

Slabs designed for bending moment in accordance with Article 3.24.3 shall be considered satisfactory in shear.

3.24.5 Cantilever Slabs

3.24.5.1 Truck Loads

Under the following formulas for distribution of loads on cantilever slabs, the slab is designed to support the load independently of the effects of any edge support along the end of the cantilever. The distribution given includes the effect of wheels on parallel elements.

3.24.5.1.1 Case A-Reinforcement Perpendicular to Traffic

Each wheel on the element perpendicular to traffic shall be distributed over a width according to the following formula:

$$E = 0.8X + 3.75 \quad (3-17)$$

The moment per foot of slab shall be (P/E)X foot-pounds, in which X is the distance in feet from load to point of support.

3.24.5.1.2 Case B-Reinforcement Parallel to Traffic

The distribution width for each wheel load on the element parallel to traffic shall be as follows:

$$E = 0.35X + 3.25, \text{ but shall not exceed 7.0 feet} \quad (3-18)$$

The moment per foot of slab shall be (P/E)X foot-pounds.

3.24.5.2 Railing Loads

A horizontal load of 54^K shall be applied to the barrier in the transverse direction at the uppermost point, and in accordance with Article 3.22, Group XI loading. The effective length of slab resisting collision loadings shall be equal to E = 10 feet where a solid parapet is used, and based on yield line theory for all other cases.

3.24.6 Slabs Supported on Four Sides

3.24.6.1 For slabs supported along four edges and reinforced in both directions, the proportion of the load carried by the short span of the slab shall be given by the following equations:

For uniformly, distributed load,

$$p = \frac{b^4}{a^4 + b^4} \quad (3-19)$$

For concentrated load at center,

$$p = \frac{b^3}{a^3 + b^3} \quad (3-20)$$

where,

- p = proportion of load carried by short span;
- a = length of short span of slab;
- b = length of long span of slab.

3.24.6.2 Where the length of the slab exceeds $1\frac{1}{2}$ times its width, the entire load shall be carried by the transverse reinforcement.

3.24.6.3 The distribution width, E, for the load taken by either span shall be determined as provided for other slabs. The moments obtained shall be used in designing the center half of the short and long slabs. The reinforcement steel in the outer quarters of both short and long spans may be reduced by 50 percent. In the design of the supporting beams, consideration shall be given to the fact that the loads delivered to the supporting beams are not uniformly distributed along the beams.

3.24.7 Median Slabs

Raised median slabs shall be designed in accordance with the provisions of this article with truck loadings so placed as to produce maximum stresses. Combined dead, live, and impact stresses shall not be greater than 150 percent of the allowable stresses. Flush median slabs shall be designed without overstress.

3.24.8 Longitudinal Edge Beams

3.24.8.1 Edge beams shall be provided for all slabs having main reinforcement parallel to traffic. The beam may consist of a slab section additionally reinforced, a beam integral with and deeper than the slab, or an integral reinforced section of slab and curb.

3.24.8.2 The edge beam of a simple span shall be designed to resist a live load moment of 0.10PS, where

- + P = wheel load in pounds;
- S = span length in feet.

3.24.8.3 For continuous spans, the moment may be reduced by 20 percent unless a greater reduction results from a more exact analysis.

3.24.9 Unsupported Transverse Edges

The design assumptions of this article do not provide for the effect of loads near unsupported edges. Therefore, at the ends of the bridge and at intermediate points where the continuity of the slab is broken, the edges shall be supported by diaphragms or other suitable means. The diaphragms shall be designed to resist the full moment and shear produced by the wheel loads which can come on them.

3.24.10 Distribution Reinforcement

3.24.10.1 To provide for the lateral distribution of the concentrated live loads, reinforcement shall be placed transverse to the main steel reinforcement in the bottoms of all slabs except culvert or bridge slabs where the depth of fill over the slab exceeds 2 feet.

3.24.10.2 The amount of distribution reinforcement shall be the percentage of the main reinforcement steel required for positive moment as given by the following formulas:

For main reinforcement parallel to traffic,

$$\text{Percentage} = \frac{100}{\sqrt{S}} \text{ Maximum } 50\% \quad (3-21)$$

For main reinforcement perpendicular to traffic,

$$\text{Percentage} = \frac{220}{\sqrt{S}} \text{ Maximum } 67\% \quad (3-22)$$

where S = the effective span length in feet.

3.24.10.3 For main reinforcement perpendicular to traffic, the specified amount of distribution reinforcement shall be used in the middle half of the slab span, and not less than 50 percent of the specified amount shall be used in the outer quarters of the slab span.

3.25 DISTRIBUTION OF WHEEL LOADS ON TIMBER FLOORING

For the calculation of bending moments in timber flooring each wheel load shall be distributed as follows.

3.25.1 Transverse Flooring

3.25.1.1 In direction of span, the wheel load shall be distributed over the width of tire as given in Article 3.30.

+ Normal to direction of span, the wheel load shall be distributed as follows:

Plank floor:

the width of plank.

Non-interconnected* nail laminated panel floor:

15 inches, but not to exceed panel width.

Non-interconnected glued laminated panel floor:

15 inches plus thickness of floor, but not to exceed panel width.

Continuous nail laminated floor and interconnected nail laminated panel floor, with adequate shear transfer between panels**:

15 inches plus thickness of floor, but not to exceed panel width.

Interconnected† glued laminated panel floor, with adequate shear transfer between panels**, not less than 6 inches thick:

15 inches plus twice thickness of floor, but not to exceed panel width.

3.25.1.2 For transverse flooring the span shall be taken as the clear distance between stringers plus one-half the width of one stringer, but shall not exceed the clear span plus the floor thickness.

3.25.1.3 One design method for interconnected glued laminated panel floors is as follows: For glued laminated panel decks using vertically laminated lumber with the panel placed in a transverse direction to the stringers and with panel interconnected using steel dowels, the determination of the deck thickness shall be based on the following equations for maximum unit primary

* The terms interconnected and non-interconnected refer to the joints between the individual nail laminated or glued laminated panels.

** This shear transfer may be accomplished using mechanical fasteners, splines, or dowels along the panel joint or other suitable means.

† The equations are developed for deck panel spans equal to or greater than the width of the tire (as specified in Article 3.30), but not greater than 200 inches.

moment and shear.* The maximum shear is for a wheel position assumed to be 15 inches or less from the centerline of the support. The maximum moment is for a wheel position assumed to be centered between the supports.

$$M_x = P(.51 \log_{10} s - K) \quad (3-23)$$

$$R_x = .034P \quad (3-24)$$

Thus,
$$t = \sqrt{\frac{6M_x}{F_b}} \quad (3-25)$$

or,

$$t = \frac{3R_x}{2F_v} \text{ whichever is greater} \quad (3-26)$$

where,

M_x = primary bending moment in inch-pounds per inch;

R_x = primary shear in pounds per inch;

x = denotes direction perpendicular to longitudinal stringers;

P = design wheel load in pounds;

s = effective deck span in inches;

t = deck thickness, in inches, based on moment or shear, whichever controls;

K = design constant depending on design load as follows:

$$H 15 \quad K = 0.47$$

$$H 20 \quad K = 0.51$$

F_b = allowable bending stress, in pounds per square inch, based on load applied parallel to the wide face of the laminations, (see Tables 13.2.2A and B);

F_v = allowable shear stress, in pounds per square inch, based on load applied parallel to the wide face of the laminations, (see Tables 13.2.2A and B).

* The terms interconnected and non-interconnected refer to the joints between the individual nail laminated or glued laminated panels.

3.25.1.4 The determination of the minimum size and spacing required of the steel dowels required to transfer the load between panels shall be based on the following equation:

$$n = \frac{1,000}{\sigma_{PL}} \times \left[\frac{\overline{R}_y}{R_D} + \frac{\overline{M}_y}{M_D} \right] \quad (3-27)$$

where

n = number of steel dowels required for the given spans;

σ_{PL} = proportional limit stress perpendicular to grain (for Douglas Fir or Southern pine, use 1,000 psi);

\overline{R}_y = total secondary shear transferred, in pounds, determined by the relationship:

$$\overline{R}_y = 6Ps/1,000 \text{ for } s \leq 50 \text{ inches} \quad (3-28)$$

or,

$$\overline{R}_y = \frac{P}{2s}(s-20) \text{ for } s > 50 \text{ inches} \quad (3-29)$$

M_y = total secondary moment transferred, in inch-pound, determined by the relationship

$$\overline{M}_y = \frac{Ps}{1,600}(s-10) \text{ for } s \leq 50 \text{ inches} \quad (3-30)$$

$$\overline{M}_y = \frac{Ps}{20} \frac{(s-30)}{(s-10)} \text{ for } s > 50 \text{ inches} \quad (3-31)$$

R_D and M_D = shear and moment capacities, respectively, as given in the following table:

Diameter of Dowel	Shear Capacity R_D	Moment Capacity M_D	Steel Stress Coefficients		Total Dowel Length Required
			C_R	C_M	
in.	lb.	in.-lb.	1/in. ²	1/in. ³	in.
0.5	600	850	36.9	81.5	8.50
.625	800	1,340	22.3	41.7	10.00
.75	1,020	1,960	14.8	24.1	11.50
.875	1,260	2,720	10.5	15.2	13.00
1.0	1,520	3,630	7.75	10.2	14.50
1.125	1,790	4,680	5.94	7.15	15.50
1.25	2,100	5,950	4.69	5.22	17.00
1.375	2,420	7,360	3.78	3.92	18.00
1.5	2,770	8,990	3.11	3.02	19.50

3.25.1.5 In addition, the dowels shall be checked to ensure that the allowable stress of the steel is not exceeded using the following equation:

$$\sigma = \frac{1}{n} (C_R \overline{R}_y + C_M \overline{M}_y) \quad (3-32)$$

where,

σ = minimum yield point of steel pins in pounds per square inch (see Table 10.32.1A);

$n, \overline{R}_y, \overline{M}_y$ = as previously defined;

C_R, C_M = steel stress coefficients as given in preceding table.

3.25.2 Plank and Nail Laminated Longitudinal Flooring

3.25.2.1 In the direction of the span, the wheel load shall be considered a point loading.

3.25.2.2 Normal to the direction of the span the wheel load shall be distributed as follows:

Plank floor:

width of plank.

Non-interconnected nail laminated or glued

laminated panel floor:

width of tire plus thickness of floor, but not to exceed panel width. Continuous nail laminated floor and interconnected nail

laminated or glued laminated panel floor, with

adequate shear transfer between panels*, not less than 6 inches thick: width of tire plus twice thickness of floor.

3.25.2.3 For longitudinal flooring the span shall be taken as the clear distance between floor beams plus one-half the width of one beam but shall not exceed the clear span plus the floor thickness.

3.25.3 Longitudinal Glued Laminate Timber Deck

3.25.3.1 Bending Moment

In calculating bending moments in glued laminated timber longitudinal decks, no longitudinal distribution of wheel loads shall be assumed. The lateral distribution shall be determined as follows.

The live load bending moment for each panel shall be determined by applying to the panel the fraction of a wheel load determined from the following equations:

TWO OR MORE TRAFFIC LANES

$$\text{Load Fraction} = \frac{W_p}{3.75 + \frac{L}{28}} \text{ or } \frac{W_p}{5.00}, \text{ whichever is greater.}$$

ONE TRAFFIC LANE

$$\text{Load Fraction} = \frac{W_p}{4.25 + \frac{L}{28}} \text{ or } \frac{W_p}{5.50}, \text{ whichever is greater.}$$

where, W_p = Width of Panel; in feet ($3.5 \leq W_p \leq 4.5$)

L = Length of span for simple span bridges and the length of the shortest span for continuous bridges in feet.

3.25.3.2 Shear

When calculating the end shears and end reactions for each panel, no longitudinal distribution of the wheel loads shall be assumed. The lateral distribution of the wheel load at the supports shall be that determined by the equation:

* This shear transfer may be accomplished using mechanical fasteners, splines, or dowels along the panel joint or spreader beams located at intervals along the panels or other suitable means.

Wheel Load Fraction per Panel

$$= \frac{W_p}{4.00} \text{ but not less than 1.}$$

For wheel loads in other positions on the span, the lateral distribution for shear shall be determined by the method prescribed for moment.

3.25.3.3 Deflections

The maximum deflection may be calculated by applying to the panel the wheel load fraction determined by the method prescribed for moment.

3.25.3.4 Stiffener Arrangement

The transverse stiffeners shall be adequately attached to each panel, at points near the panel edges, with either steel plates, thru-bolts, C-clips or aluminum brackets. The stiffeners spacing required will depend upon the spacing needed in order to prevent differential panel movement; however, a stiffener shall be placed at midspan with additional stiffeners placed at intervals not to exceed 10 feet. The stiffness factor EI of the stiffener shall not be less than 80,000 kip-in².

3.25.4 Continuous Flooring

If the flooring is continuous over more than two spans, the maximum bending moment shall be assumed as being 80 percent of that obtained for a simple span.

3.26 DISTRIBUTION OF WHEEL LOADS AND DESIGN OF COMPOSITE WOOD-CONCRETE MEMBERS

3.26.1 Distribution of Concentrated Loads for Bending Moment and Shear

3.26.1.1 For freely supported or continuous slab spans of composite wood-concrete construction, as described in Article 20.19.1 Division II, the wheel loads shall be distributed over a transverse width of 5 feet for bending moment and a width of 4 feet for shear.

3.26.1.2 For composite T-beams of wood and concrete, as described in Article 20.19.2-Division II, the effective flange width shall not exceed that given in Article 10.38.3. Shear connectors shall be capable of resisting both vertical and horizontal movement.

3.26.2 Distribution of Bending Moments in Continuous Spans

3.26.2.1 Both positive and negative moments shall be distributed in accordance with the following table:

Maximum Bending Moments-Percent of Simple Span Moment

Span	Maximum Dead Load Moments				Maximum Live Load Moments			
	Wood Subdeck		Composite Slab		Concentrated Load		Uniform Load	
	Pos.	Neg.	Pos.	Neg.	Pos.	Neg.	Pos.	Neg.
Interior	50	50	55	45	75	25	75	55
End	70	60	70	60	85	30	85	65
2-Span ^a	65	70	60	75	85	30	80	75

^aContinuous beam of 2 equal spans.

3.26.2.2 Impact should be considered in computing stresses for concrete and steel, but neglected for wood.

3.26.3 Design

The analysis and design of composite wood-concrete members shall be based on assumptions that account for the different mechanical properties of the components. A suitable procedure may be based on the elastic properties of the materials as follows:

$$\frac{E_c}{E_w} = 1 \text{ for slab in which the net concrete thickness is less than half the overall depth of the composite section}$$

$$\frac{E_c}{E_w} = 2 \text{ for slab in which the net concrete thickness is at least half the overall depth of the composite section}$$

$$\frac{E_s}{E_w} = 18.75 \text{ (for Douglas fir and Southern pine)}$$

in which

- E_c = modulus of elasticity of concrete;
- E_w = modulus of elasticity of wood;
- E_s = modulus of elasticity of steel.

3.27 DISTRIBUTION OF WHEEL LOADS ON STEEL GRID FLOORS*

3.27.1 General

3.27.1.1 The grid floor shall be designed as continuous, but simple span moments may be used and reduced as provided in Article 3.24.

3.27.1.2 The following rules for distribution of loads assume that the grid floor is composed of main elements that span between girders, stringers, or cross beams, and secondary elements that are capable of transferring load between the main elements.

3.27.1.3 Reinforcement for secondary elements shall consist of bars or shapes welded to the main steel.

3.27.2 Floors Filled with Concrete

3.27.2.1 The distribution and bending moment shall be as specified for concrete slabs, Article 3.24. The following items specified in that article shall also apply to concrete filled steel grid floors:

- Longitudinal edge beams
- Unsupported transverse edges
- Span lengths

3.27.2.2 The strength of the composite steel and concrete slab shall be determined by means of the "transformed area" method. The allowable stresses shall be as set forth in Articles 8.15.2, 8.16.1, and 10.32.

3.27.3 Open Floors

3.27.3.1 A wheel load shall be distributed, normal to the main elements, over a width equal to 1¹/₄ inches per ton of axle load plus twice the distance center to center of main elements. The portion of the load

* Provisions in this article shall not apply to orthotropic bridge superstructures.

assigned to each main element shall be applied uniformly over a length equal to the rear tire width (20 inches for H 20, 15 inches for H 15).

3.27.3.2 The strength of the section shall be determined by the moment of inertia method. The allowable stresses shall be as set forth in Article 10.32.

3.27.3.3 Edges of open grid steel floors shall be supported by suitable means as required. These supports may be longitudinal or transverse, or both, as may be required to support all edges properly.

3.27.3.4 When investigating for fatigue, the minimum cycles of maximum stress shall be used.

3.28 DISTRIBUTING OF LOADS FOR BENDING MOMENT IN SPREAD BOX GIRDERS*

3.28.1 Interior Beams

The live load bending moment for each interior beam in a spread box beam superstructure shall be determined by applying to the beam the fraction (D.F.) of the wheel load (both front and rear) determined by the following equation:

$$D.F. = \frac{2N_L}{N_B} + k \frac{S}{L} \quad (3-33)$$

where,

- N_L = number of design traffic lanes (Article 3.6);
- N_B = number of beams ($4 \leq N_B \leq 10$);
- S = beam spacing in feet ($6.57 \leq S \leq 11.00$);
- L = Span length in feet;
- $k = 0.07W - N_L(0.10N_L - 0.26) - 0.20N_B - 0.12$;

$$(3-34)$$

W = numeric value of the roadway width between curbs expressed in feet ($32 \leq W \leq 66$).

* The provisions of Article 3.12, Reduction in Load Intensity, were not applied in the development of the provisions presented in 3.28.1 and 3.28.2.

3.28.2 Exterior Beams

The live load bending moment in the exterior beams shall be determined by applying to the beams the reaction of the wheel loads obtained by assuming the flooring to act as a simple span (of length S) between beams, but shall not be less than $2N_L/N_B$.

3.29 MOMENTS, SHEARS, AND REACTIONS

Maximum moments, shears, and reactions are given in tables, Appendix A, for H 15, H 20, HS 15, and HS 20 loadings. They are calculated for the standard truck or the lane loading applied to a single lane on freely supported spans. It is indicated in the table whether the standard truck or the lane loadings produces the maximum stress.

3.30 TIRE CONTACT AREA

The tire contact area shall be assumed as a rectangle with an area in square inches of $0.01P$, and a Length in Direction of Traffic/Width of Tire ratio of $1/2.5$, in which P = wheel load in pounds.

Section 3 Commentary - Loads

3.10.4 Centrifugal Forces

This specification has been revised to require a centrifugal force generated by the reaction due to the controlling live load. This will eliminate inconsistency which required a considerable increase in reinforcement and a corresponding increase in the probable yield strength. Single column bents were especially affected in the transverse direction. For example, if one permit load generated the critical moment, a significant centrifugal moment, generated by HS trucks in all lanes, formerly would have been added to it. For this example, the revised specification will require adding only the centrifugal moment generated by one permit truck traveling at a slow speed.

+ **3.14.1.6** Past experience has shown that "marching" can generate unacceptable movements at approximately 2 Hz in the vertical direction and 1 Hz in the lateral direction. Fundamental frequency is defined as vibrations on the predominant vertical mode of a bridge, expressed in cycles per second, or the inverse of the natural period. References"

- + • "Guide Specification for Design of Pedestrian Bridges", AASHTO, August 1977.
- + • Bachmann, H. "Case Studies of Structures with Man-Induced Vibrations", ASCE J. of Structural Engineering, Vol. 118, No. 3, March 1992.
- + • Dallard et. al. "The London Millennium Footbridge", The Structural Engineer, Vol. 79/No. 22, 20 November 2001.

+ **3.24.2.1** The designer should consider whether or not vehicular barrier railing will remain in place during the lifespan of the structure. In anticipation of bridge widenings, Article 3.23.2.3.1.4 prohibits the exterior girder from having less capacity than the interior girders. It may be more prudent to design the slab or supporting member as if the barrier was removed. Note that a vehicular barrier rail is an unmountable structure. A standard sidewalk curb is mountable and should not be considered a vehicular barrier rail.