

SECTION 10 - STRUCTURAL STEEL

(1996 Sixteenth Edition with 1997 - 2001 Interim Revisions)

Part A General Requirements and Materials

10.1 APPLICATION

+ 10.1.1 General

+ The specifications of this section are intended
 + for design of steel components, splices and connections
 + for straight beam and girder structures, frames, trusses,
 + arches and metal structures, as applicable. For horizon-
 + tally curved bridges, see the current AASHTO Guide
 + Specifications for Horizontally Curved Bridges.

+ 10.1.2 Notations

- + A = area of cross section (in.²) (Articles 10.37.1.1,
 + 10.34.4.7, 10.48.1.1, 10.48.4.2, 10.48.5.3
 + and 10.55.1)
- + A = bending moment coefficient (Article
 + 10.50.1.1.2)
- + A_e = effective area of a flange or splice plate with
 + holes (in.²) (Articles 10.18.2.2.1, 10.18.2.2.3)
- + A_F = amplification factor (Articles 10.37.1.1 and
 + 10.55.1)
- + A_f = sum of the area of the fillers on the top and
 + bottom of the connected plate (in.²) (Article
 + 10.18.1.2)
- + $(AF_y)_{bf}$ = product of area and yield strength for bottom
 + flange of steel section (lb) (Article 10.50.1.1.1)
- + $(AF_y)_c$ = product of area and yield strength of that
 + part of reinforcing which lies in the com-
 + pression zone of the slab (lb.) (Article
 + 10.50.1.1.1)
- + $(AF_y)_{tf}$ = product of area and yield strength for top
 + flange of steel section (lb.) (Article
 + 10.50.1.1.1)
- + $(AF_y)_w$ = product of area and yield strength for web of
 + steel section (lb.) (Article 10.50.1.1.1)
- + A_f = area of flange (in.²) (Articles 10.39.4.4.2,
 + 10.48.2.1, 10.53.1.2, and 10.56.3)

- + A_{fc} = area of compression flange (in.²) (Article
 + 10.48.4.1)
- + A_g = gross area of whole connected material (in.²)
 + (Article 10.19.4.2)
- + A_g = gross area of a flange or splice plate (in.²)
 + (Article 10.18.2.2.1 and 10.18.2.2)
- + A_n = net area of the fastener (in.²) (Article
 + 10.32.3.2.1 and 10.57.3.1)
- + A_p = smaller of either the connected plate area or
 + the sum of the splice plate areas on the top
 + and bottom of the connected plate (in.²)
 + (Article 10.18.1.2)
- + A_r^s = total area of longitudinal slab reinforcement
 + steel for each beam over interior support
 + (in.²) (Article 10.38.5.1.3)
- + A_s = area of steel section (in.²) (Articles
 + 10.38.5.1.2, 10.54.1.1, and 10.54.2.1)
- + A_s^r = total area of longitudinal reinforcing steel at
 + the interior support within the effective flange
 + width (in.²) (Article 10.38.5.1.2)
- + A_{tg} = gross area along the plane resisting tension
 + (in.²) (Article 10.19.4)
- + A_{tn} = net area along the plane resisting tension
 + (in.²) (Article 10.19.4)
- + A_{vg} = gross area along the plane resisting shear
 + (in.²) (Article 10.19.4)
- + A_{vn} = net area along the plane resisting shear (in.²)
 + (Article 10.19.4)
- + A_w = area of web of beam (in.²) (Article 10.53.1.2)
- + a = distance from center of bolt under consider-
 + ation to edge of plate (in.) (Articles
 + 10.32.3.3.2 and 10.56.2)
- + a = spacing of transverse stiffeners (in.) (Article
 + 10.39.4.4.2)
- + a = depth of stress block (in.) (Figure 10.50A)
- + B = constant based on the number of stress cycles
 + (Article 10.38.5.1.1)

B	= constant for stiffeners (Articles 10.34.4.7 and 10.48.5.3)	D	= clear distance between flanges (in.) (Article 10.15.2)
+ b	= compression flange width (in.) (Tables 10.32.1A and 10.34.2A, Article 10.34.2.1.3)	D	= clear unsupported distance between flange components (in.) (Table 10.34.3A, 10.37.2A, 10.48.5A, 10.55.2A, Articles 10.18.2.3.4, 10.18.2.3.5, 10.18.2.3.7, 10.18.2.3.8, 10.18.2.3.9, 10.34.3, 10.34.4, 10.34.5, 10.37.2, 10.48.1, 10.48.2, 10.48.4, 10.48.5, 10.48.6, 10.48.8, 10.49.2, 10.49.3.2, 10.50.2.1, and 10.55.2)
+ b	= distance from center of bolt under consideration to toe of fillet of connected part (in.) (Articles 10.32.3.3.2 and 10.56.2)	D'	= distance from the top of concrete slab to the neutral axis at which a composite section in positive bending theoretically reaches its plastic moment capacity when the maximum compressive strain in concrete slab is at 0.003 (Article 10.50.1.1.2)
+ b	= effective flange width (in.) (Articles 10.38.3, 10.38.5.1.2 and 10.50.1.1.1)	D_c	= clear distance between the neutral axis and the compression flange (in.) (Table 10.34.3A, Articles 10.48.2.1(b), 10.48.4.1, 10.49.2, 10.49.3.2.2 and 10.50)
+ b	= widest flange width (in.) (Article 10.15.2.1)	D_{cp}	= depth of web in compression at the plastic moment (in.) (Articles 10.50.1.1.2 and 10.50.2.1)
+ b	= distance from edge of plate or edge of perforation to the point of support (in.) (Article 10.35.2.3)	D_p	= distance from top of the slab to the plastic neutral axis at the plastic moment (in.) (Article 10.50.1.1.2)
+ b	= unsupported distance between points of support (in.) (Table 10.35.2A and Article 10.35.2.3)	d	= bolt diameter (in.) (Table 10.32.3B)
+ b	= flange width between webs (in.) (Articles 10.37.3.1, 10.39.4.2, and 10.51.5.1)	d	= diameter of stud (in.) (Article 10.38.5.1)
+ b'	= width of stiffeners (in.) (Articles 10.34.5.2, 10.34.6, 10.37.2.4, 10.39.4.5.1, and 10.55.2)	d	= depth of beam or girder (in.) (Article 10.13, Table 10.32.1A, Articles 10.48.2, 10.48.4.1, and 10.50.1.1.2)
+ b'	= width of a projecting flange element, angle, or stiffener (in.) (Articles 10.34.2.2, 10.37.3.2, 10.39.4.5.1, 10.48.1, 10.48.2, 10.48.5.3, 10.50, 10.51.5.5, and 10.55.3)	d	= diameter of rocker or roller (in.) (Article 10.32.4.2)
+ b_{eb}	= width of the body of the eyebar (in.) (Article 10.25.3)	d_b	= beam depth (in.) (Article 10.56.3)
+ C	= web buckling coefficient (Articles 10.34.4, 10.48.5.3, and 10.48.8.)	d_c	= column depth (in.) (Article 10.56.3)
+ C	= compressive force in the slab (lb.) (Article 10.50.1.1.1)	d_o	= spacing of intermediate stiffener (in.) (Articles 10.34.4, 10.34.5, 10.48.5.3, 10.48.6.3, and 10.48.8)
+ C'	= compressive force in top portion of steel section (lb.) (Article 10.50.1.1.1)	d_s	= distance from the centerline of a plate longitudinal stiffener or the gage line of an angle longitudinal stiffener to the inner surface or the leg of the compression flange component (in.) (Table 10.34.3A, 10.34.5A, Articles 10.34.5 and 10.49.3.2)
+ C_b	= bending coefficient (Table 10.32.1A, Article 10.48.4.1)	E	= modulus of elasticity of steel (psi) (Table 10.32.1A and Articles 10.15.3, 10.36, 10.37, 10.39.4.4.2, 10.54.1, 10.54.2 and 10.55.1)
+ C_c	= column slenderness ratio dividing elastic and inelastic buckling (Table 10.32.1A)	E_c	= modulus of elasticity of concrete (psi) (Article 10.38.5.1.2)
+ C_{mx}	= coefficient applied to bending term in interaction formula for prismatic members; dependent upon member curvature caused by applied moments about the X axis (Articles 10.36 and 10.54.2)		
+ C_{my}	= coefficient applied to bending term in interaction formula for prismatic members; dependent upon member curvature caused by applied moments about the Y axis (Articles 10.36 and 10.54.2)		
+ c	= buckling stress coefficient (Article 10.51.5.2)		

+ e	= distance from the centerline of the splice to the centroid of the connection on the side of the joint under consideration (in.) (Articles 10.18.2.3.3, 10.18.2.3.5 and 10.18.2.3.7)	F_{um}	= maximum bending strength of either the top or bottom flange, whichever flange has the larger ratio of (f_s/F_{um}) (Article 10.48.8.2)	+ + +
+ F_a	= allowable axial stress (psi) (Table 10.32.1A and Articles 10.36, 10.37.1.2, and 10.55.1)	F_v	= allowable shear stress (psi) (Tables 10.32.1A, 10.32.3B and 10.34.3A, and Articles 10.18.2.3.6, 10.32.2, 10.32.3, 10.34.4, 10.40.2.2)	+ + +
+ F_b	= allowable bending stress (psi) (Table 10.32.1A and Articles 10.37.1.2 and 10.55.1)	F_v	= shear strength of a fastener (psi) (Article 10.56.1.3)	+ +
+ F_{bc}	= allowable compression flange stress specified in Table 10.32.1A (psi) (Article 10.18.2.3.8)	F_w	= design shear stress in the web at the point of splice defined in Article 10.18.2.3.6 (psi) (Articles 10.18.2.3.6, 10.18.2.3.7 and 10.18.2.3.9)	+ + +
+ F_{bs}	= allowable block shear rupture stress (psi) (Article 10.19.14)	F_y	= specified minimum yield strength of steel (psi) (Table 10.34.2A, 10.34.3A, 10.34.5A, 10.35.2A, 10.48.5A, and Articles 10.15.2.1, 10.15.3, 10.16.11, 10.19.4, 10.32.1, 10.32.4, 10.34, 10.35, 10.37.1.3, 10.38.5, 10.39.4, 10.40.2.2, 10.41.4.6, 10.46, 10.48, 10.49, 10.50, 10.51.5, and 10.54)	+ + + + + +
+ F_{bt}	= allowable tension flange stress specified in Table 10.32.1A (psi) (Article 10.18.2.3.8)	F_y^r	= specified minimum yield strength of the reinforcing steel (psi) (Article 10.38.5.1.2)	+ +
+ F_{bx}	= allowable compressive bending stress about the X axis (psi) (Article 10.36)	F_{yf}	= specified minimum yield strength of the flange (psi) (Articles 10.18.2.2.2, 10.18.2.3.4, 10.48.1.1, and 10.53.1)	+ + +
+ F_{by}	= allowable compressive bending stress about the Y axis (psi) (Article 10.36)	F_{yw}	= specified minimum yield strength of the web (psi) (Articles 10.18.2.3.4 and 10.53.1)	+ + +
+ F_{cr}	= critical stress of the compression flange plate or member (psi) (Articles 10.51.1, 10.51.5, 10.54.1.1, and 10.54.2.1)	f	= maximum induced stress in the bottom flange (psi) (Article 10.21.2)	+ + +
+ F_{cu}	= design stress for the flange at a point of splice (psi) (Article 10.18.2.2.2)	f	= maximum compressive stress (psi) (Article 10.41.4.6)	+ + +
+ F_D	= maximum horizontal force (lb.) (Article 10.20.2.2)	f_{DL}	= non-composite dead-load stress in the compression flange (psi) (Articles 10.34.5.1 and 10.49.3.2)	+ + +
+ F_e	= Euler buckling stress (psi) (Articles 10.37.1, 10.54.2, and 10.55.1)	f_{DL+LL}	= total non-composite and composite dead load plus the composite live-load stress in compression flange at the most highly stressed section of the web (psi) (Articles 10.34.5.1 and 10.49.3.2)	+ + + +
+ F_e'	= Euler stress divided by a factor of safety (psi) (Article 10.36)	f_a	= calculated axial compression stress (psi) (Table 10.35.2A, 10.37.2A, 10.55.2A, and Articles 10.36 and 10.37)	+ + +
+ F_p	= allowable bearing stress on high-strength bolts or connected material (psi) (Table 10.32.3B)	f_b	= calculated compressive bending stress (psi) (Table 10.34.2A, 10.34.3A, 10.37.2A, 10.55.2A, and Articles 10.37 and 10.39)	+ + +
+ F_s	= limiting bending stress (psi) (Article 10.34.4)	f_{bx}	= calculated compressive bending stress about the x axis (psi) (Article 10.36)	+ +
+ F_{sr}	= allowable range of fatigue stress (psi) (Table 10.3.1A)	f_{by}	= calculated compressive bending stress about the y axis (psi) (Article 10.36)	+ +
+ $F.S.$	= factor of safety (Table 10.32.1A and Articles 10.36 and 10.37.1.3)			+ +
+ F_t'	= reduced allowable tensile stress on rivet or bolt due to the applied shear stress (psi) (Articles 10.32.3.3.4 and 10.56.1.3.3)			+ +
+ F_u	= specified minimum tensile strength (psi) (Tables 10.2C, 10.32.1A and 10.32.3B, Articles 10.18.4 and 10.19.4)			+ +
+ F_u	= tensile strength of electrode classification (psi) (Table 10.56A and Article 10.32.2)			+ +

<p>+ f'_c = specified compressive strength of concrete as determined by cylinder tests at age of 28 days (psi) (Articles 10.38.1, 10.38.5.1.2, 10.45.3, and 10.50.1.1.1)</p> <p>+ f_{dl} = top flange compressive stress due to noncomposite dead load (psi) (Table 10.34.2A)</p> <p>+ f_o = maximum flexural stress due to Group I loading divided by 1.3 at the mid-thickness of the flange under consideration for the smaller section at the point of splice (psi) (Articles 10.18.2.2.2 and 10.18.2.3.5)</p> <p>+ f_{of} = flexural stress due to Group I loading divided by 1.3 at the mid-thickness of the other flange at the point of splice concurrent with f_o in the flange under consideration (psi) (Article 10.18.2.3.5)</p> <p>+ f_r = range of stress due to live load plus impact, in the slab reinforcement over the support (psi) (Article 10.38.5.1.3)</p> <p>+ f_s = maximum longitudinal bending stress in the flange of the panels on either side of the transverse stiffener (psi) (Article 10.39.4.4)</p> <p>+ f_t = calculated tensile stress (psi) (Articles 10.32.3.3.3 and 10.56.1.3.3)</p> <p>+ f_v = calculated shear stress (psi) (Table 10.34.3A, Articles 10.32.3.2.3 and 10.34.4.4)</p> <p>+ g = gage between fasteners (in.) (Articles 10.16.14 and 10.24.5)</p> <p>+ H = height of stud (in.) (Article 10.38.5.1.1)</p> <p>+ H_w = horizontal design force resultant in the web at a point of splice (lb.) (Articles 10.18.2.3.8 and 10.18.2.3.9)</p> <p>+ H_{wo} = overload horizontal design force resultant in the web at a point of splice (lb.) (Article 10.18.2.3.5)</p> <p>+ H_{wu} = horizontal design force resultant in the web at a point of splice (lb.) (Articles 10.18.2.3.4 and 10.18.2.3.5)</p> <p>+ h = average flange thickness of the channel flange (in.) (Article 10.38.5.1.2)</p> <p>+ I = moment of inertia (in.⁴) (Articles 10.34.4, 10.34.5, 10.38.5.1.1, 10.48.5.3, and 10.48.6.3)</p> <p>+ I_s = moment of inertia of stiffener (in.⁴) (Articles 10.37.2, 10.39.4.4.1, and 10.51.5.4)</p> <p>+ I_t = moment of inertia of transverse stiffeners (in.⁴) (Article 10.39.4.4.2)</p>	<p>I_y = moment of inertia of member about the vertical axis in the plane of the web (in.⁴) + (Article 10.48.4.1)</p> <p>I_{yc} = moment of inertia of compression flange about the vertical axis in the plane of the web (in.⁴) (Table 10.32.1A, Article 10.48.4.1)</p> <p>J = required ratio of rigidity of one transverse stiffener to that of the web plate (Articles 10.34.4.7 and 10.48.5.3) +</p> <p>J = St. Venant torsional constant (in.⁴) (Table 10.32.1A, Article 10.48.4.1)</p> <p>K = effective length factor in plane of buckling (Table 10.32.1A and Articles 10.37, 10.54.1, 10.54.2 and Appendix C) +</p> <p>K_b = effective length factor in plane of buckling (Article 10.36) +</p> <p>K_h = hole size factor (Articles 10.32.3.2 and 10.57.3.1)</p> <p>k = constant: 0.75 for rivets; 0.6 for high-strength bolts with thread excluded from shear plane (Article 10.32.3.3.4)</p> <p>k = buckling coefficient (Table 10.34.3A, Articles 10.34.4, 10.39.4.3, 10.48.8, and 10.51.5.4) +</p> <p>k = distance from outer face of flange to toe of web fillet of member to be stiffened (in.) (Article 10.56.3) +</p> <p>k_I = buckling coefficient (Article 10.39.4.4)</p> <p>L = actual unbraced length (in.) (Table 10.32.1A and Articles 10.7.4, 10.15.3, and 10.55.1) +</p> <p>L = 1/2 of the length of the arch rib (in.) (Article 10.37.1) +</p> <p>L = distance between transverse beams (in.) (Article 10.41.4.6) +</p> <p>L_b = unbraced length (in.) (Table 10.48.2.1A and Articles 10.36, 10.48.1.1, 10.48.2.1, 10.48.4.1, and 10.53.1.3) +</p> <p>L_c = length of member between points of support (in.) (Article 10.54.1.1) +</p> <p>L_c = clear distance between the holes or between the hole and the edge of the material in the direction of the applied bearing force (in.) (Table 10.32.3B and Article 10.56.1.3.2) +</p> <p>L_p = limiting unbraced length for the yield moment capacity (in.) (Article 10.48.4.1) +</p> <p>L_r = limiting unbraced length for elastic lateral torsional buckling moment capacity (in.) + (Article 10.48.4.1)</p>
--	--

+ l	= member length (in.) (Table 10.32.1A and Article 10.35.1)	+ M_{wo}	= overload design moment at the point of splice representing the portion of the flexural moment assumed to be resisted by the web (lb-in.) (Article 10.18.2.3.5)	+ +
+ M	= maximum bending moment (lb-in.) (Articles 10.48.2, 10.48.8 and 10.54.2)	+ M_{wu}	= design moment at a point of splice representing the portion of the flexural moment assumed to be resisted by the web (lb-in.) (Articles 10.18.2.3.4 and 10.18.2.3.5)	+ +
+ M_1	= smaller end moment at the end of a member (lb-in.) (Table 10.36A)	+ M_y	= moment capacity at first yield (lb-in.) (Articles 10.18.2.2.2 and 10.50.1.1.2)	+ +
+ M_1 & M_2	= moments at two adjacent braced points (lb-in.) (Table 10.36A)	+ N_1 & N_2	= number of shear connectors (Article 10.38.5.1.2)	+ +
+ M_A	= absolute value of moment at quarter point of the unbraced beam segment (lb-in.) (Table 32.1.A and Article 10.48.4.1)	+ N_b	= number of bolts in the joint (Articles 10.32.3.2.1 and 10.57.3.1)	+ +
+ M_B	= absolute value of moment at midpoint of the unbraced beam segment (lb-in.) (Table 32.1.A and Article 10.48.4.1)	+ N_c	= number of additional connectors for each beam at point of contraflexure (Article 10.38.5.1.3)	+ +
+ M_C	= absolute value of moment at three-quarter point of the unbraced beam segment (lb-in.) (Table 32.1.A and Article 10.48.4.1)	+ N_s	= number of slip planes in a slip critical connection (Articles 10.32.3.2.1 and 10.57.3.1)	+ +
+ M_c	= column moment (lb-in.) (Article 10.56.3.2)	+ N_w	= number of roadway design lanes (Article 10.39.2)	+ +
+ M_{cD}	= moments caused by dead load acting on composite girder (lb-in.) (Article 10.50.1.2.2)	+ n	= ratio of modulus of elasticity of steel to that of concrete (Article 10.38.1)	+ +
+ M_{max}	= absolute value of maximum moment in the unbraced beam segment (lb-in.) (Table 32.1.A and Article 10.48.4.1)	+ n	= number of longitudinal stiffeners (Articles 10.39.4.3, 10.39.4.4, and 10.51.5.4)	+ +
+ M_p	= full plastic moment of the section (lb-in.) (Articles 10.50.1.1.2 and 10.54.2.1)	+ P	= allowable compressive axial load on members (lb.) (Article 10.35.1)	+ +
+ M_r	= lateral torsional buckling moment capacity (lb-in.) (Articles 10.48.4.1 and 10.53.1.3)	+ P	= axial compression on the member (lb.) (Articles 10.48.1.1, 10.48.2.1, and 10.54.2.1)	+ +
+ M_s	= elastic pier moment for loading producing maximum positive moment in adjacent span (lb-in.) (Article 10.50.1.1.2)	+ P, P_1, P_2 & P_3	= force in the slab or in the steel girder (lb.) (Article 10.38.5.1.2)	+ +
+ M_{sD}	= moments caused by dead load acting on steel girder (lb-in.) (Article 10.50.1.2.2)	+ P_{cf}	= design force for the flange at a point of splice (lb.) (Article 10.18.2.2.3)	+ +
+ M_u	= design bending strength (lb-in.) (Articles 10.18.2.2.2, 10.48, 10.51.1, 10.53.1, and 10.54.2.1)	+ P_{cu}	= design force for the flange at a point of splice (lb.) (Article 10.18.2.2.2)	+ +
+ M_v	= design moment due to the eccentricity of the design shear at a point of splice (lb-in.) (Articles 10.18.2.3.7 and 10.18.2.3.9)	+ P_{fo}	= overload design force for the flange at a point of splice (lb.) (Article 10.18.2.2.2)	+ +
+ M_{vo}	= overload design moment due to the eccentricity of the design shear at a point of splice (lb-in.) (Article 10.18.2.3.5)	+ P_s	= allowable slip resistance (lb.) (Article 10.32.2.2.1)	+ +
+ M_{vu}	= design moment due to the eccentricity of the design shear at a point of splice (lb-in.) (Articles 10.18.2.3.3 and 10.18.2.3.5)	+ P_u	= design axial compression strength (lb.) (Article 10.54.1.1)	+ +
+ M_w	= overload design moment at the point of splice representing the portion of the flexural moment assumed to be resisted by the web (lb-in.) (Articles 10.18.2.3.8 and 10.18.2.3.9)	+ p	= allowable bearing (lb/in.) (Article 10.32.4.2)	+ +
		+ Q	= prying tension per bolt (lb.) (Articles 10.32.3.3.2 and 10.56.2)	+ +

+ Q	= statical moment about the neutral axis (in. ³) (Article 10.38.5.1.1)	S_{xt}	= section modulus with respect to the tension flange (in. ³) (Article 10.53.1.2)	+
R	= radius (ft.) (Article 10.15.2.1)	s	= pitch of any two successive holes in the chain (in.) (Article 10.16.14.2)	+
R	= number of design lanes per box girder (Article 10.39.2.1)	T	= range in tensile stress (psi) (Table 10.3.1B)	+
R	= reduction factor for hybrid girders (Articles 10.18.2.2.2, 10.18.2.2.4, 10.18.2.2.8, 10.40.2.1.1, 10.53.1.2, and 10.53.1.3)	T	= calculated direct tension per bolt (lb.) (Articles 10.32.3 and 10.56.2)	+
R_b	= bending capacity reduction factor (Articles 10.48.4.1, and 10.53.1.3)	T	= arch rib thrust at the quarter point from dead + live + impact loading (lb.) (Articles 10.37.1 and 10.55.1)	+
+ Rev	= a range of stress involving both tension and compression during a stress cycle (psi) (Table 10.3.1B)	T_b	= required minimum bolt tension stress (psi) (Articles 10.32.3.2 and 10.57.3.1)	+
+ R_s	= design slip strength of a fastener (lb.) (Article 10.57.3.1)	T_{bs}	= design block shear rupture strength (lb.) (Article 10.19.4)	+
+ R_s	= vertical force at connections of vertical stiffeners to longitudinal stiffeners (lb.) (Article 10.39.4.4.8)	t	= thickness of the thinner outside plate or shape (in.) (Article 10.24.6)	+
+ R_t	= design tension strength of a fastener (lb.) (Article 10.56.1.3.3)	t	= thickness of members in compression (in.) (Table 10.35.2A and Article 10.35.2)	+
+ R_v	= design shear strength of a fastener (lb.) (Article 10.56.1.3.2)	t	= thickness of thinnest part connected (in.) (Articles 10.32.3.3.2 and 10.56.2)	+
+ R_w	= vertical web force (lb.) (Article 10.39.4.4.7)	t	= thickness of the wearing surface (in.) (Article 10.41.2)	+
+ r	= radius of gyration (in.) (Articles 10.35.1, 10.37.1, 10.41.4.6, 10.48.6.3, 10.54.1.1, 10.54.2.1, and 10.55.1)	t	= flange thickness (in.) (Articles 10.18.2.2.1, 10.34.2.1, 10.39.4.2, 10.48.1.1, 10.48.2.1, 10.50, and 10.51.5.1)	+
+ r_b	= radius of gyration in plane of bending (in.) (Article 10.36)	t	= thickness of a flange angle (in.) (Article 10.34.2.2)	+
+ r_y	= radius of gyration with respect to the Y-Y axis (in.) (Article 10.48.1.1)	t	= thickness of stiffener (in.) (Article 10.48.5.3)	+
+ r'	= radius of gyration of the compression flange about the axis in the plane of the web (in.) (Table 10.32.1A, and Article 10.48.4.1)	t_b	= thickness of flange delivering concentrated force (in.) (Article 10.56.3.2)	+
+ S	= section modulus (in. ³) (Articles 10.48.2, 10.51.1, and 10.53.1.3)	t_c	= thickness of flange of member to be stiffened (in.) (Article 10.56.3.2)	+
+ S_r	= range of horizontal shear (lb.) (Article 10.38.5.1.1)	t_f	= thickness of the flange (in.) (Table 10.37.2A, 10.55.2A, and Articles 10.37.3, 10.55.3 and 10.39.4.3)	+
+ S_s	= section modulus of transverse stiffener (in. ³) (Articles 10.39.4.4 and 10.48.6.3)	t_h	= thickness of the concrete haunch above the beam or girder top flange (in.) (Article 10.50.1.1.2)	+
+ S_t	= section modulus of longitudinal or transverse stiffener (in. ³) (Article 10.48.6.3)	t_s	= thickness of stiffener (in.) (Table 10.34.5A, 10.37.2A, 10.48.5A, 10.55.2A, and Article 10.34.5, 10.37.2, 10.48.5.3 and 10.55.2)	+
+ S_u	= design shear strength of the shear connector (lb.) (Article 10.38.5.1.2)	t_s	= slab thickness (in.) (Articles 10.38.5.1.2, 10.50.1.1.1, and 10.50.1.1.2)	+
+ S_{xc}	= section modulus with respect to the compression flange (in. ³) (Table 10.32.1A, and Article 10.48.4.1)			

+ t_f	= thickness of top flange (in.) (Article 10.50.1.1.1)	Y_o	= distance from the neutral axis to the extreme outer fiber (in.) (Article 10.15.3)	+
+ t_w	= web thickness (in.) (Table 10.34.3A, 10.48.5A, 10.55.2A, Articles 10.15.2.1, 10.18.2.3.4, 10.18.2.3.5, 10.18.2.3.7, 10.18.2.3.8, 10.18.2.3.9, 10.34.3, 10.34.4, 10.34.5, 10.37.2, 10.48, 10.49.2, 10.49.3, 10.55.2, and 10.56.3)	\bar{y}	= location of steel sections from neutral axis (in.) (Article 10.50.1.1.1)	+
+ t'	= thickness of outstanding stiffener element (in.) (Articles 10.39.4.5.1 and 10.51.5.5)	Z	= plastic section modulus (in. ³) (Articles 10.48.1, 10.53.1.1, and 10.54.2.1)	+
+ V	= shearing force (lb.) (Articles 10.35.1, 10.48.5.3, 10.48.8, and 10.51.3)	Z_r	= allowable range of horizontal shear on an individual connector (lb.) (Article 10.38.5.1)	+
+ V_o	= maximum shear in the web due to Group I loading divided by 1.3 at the point of splice (lb.) (Article 10.18.2.3.5)	α	= constant based on the number of stress cycles (Article 10.38.5.1.1)	+
+ V_p	= shear yielding strength of the web (lb.) (Articles 10.48.8 and 10.53.1.4)	α	= specified minimum yield strength of the web divided by the specified minimum yield strength of the tension flange (Articles 10.40.2, 10.40.4 and 10.53.1.2)	+
V_r	= range of shear due to live loads and impact (lb.) (Article 10.38.5.1.1)	α	= factor for flange splice design equal to 1.0 except that a lower value equal to (M_u/M_y) may be used for flanges in compression at sections where M_u is less than M_y (Article 10.18.2.2.2)	+
+ V_u	= design shear strength (lb.) (Articles 10.18.2.3.2, 10.48.5.3, 10.48.8, and 10.53.1.4)	β	= area of the web divided by the area of the tension flange (Articles 10.40.2 and 10.53.1.2)	+
V_v	= calculated vertical shear (lb.) (Article 10.39.3.1)	β	= factor applied to gross area of flange and splice plate in computing the effective area (Article 10.18.2.2.1)	+
+ V_w	= design shear for a web (lb.) (Articles 10.39.3.1 and 10.51.3)	θ	= angle of inclination of the web plate to the vertical (Articles 10.39.3.1 and 10.51.3)	+
+ V_{wu}	= design shear in the web at the point of splice (lb.) (Articles 10.18.2.3.2, 10.18.2.3.3 and 10.18.2.3.5)	Ψ	= ratio of total cross sectional area to the cross sectional area of both flanges (Article 10.15.2)	+
+ W	= length of a channel shear connector, (in.) (Article 10.38.5.1.2)	Ψ	= distance from the outer edge of the tension flange to the neutral axis divided by the depth of the steel section (Articles 10.40.2 and 10.53.1.2)	+
W_L	= fraction of a wheel load (Article 10.39.2)	Δ	= amount of camber (in.) (Article 10.15.3)	+
+ W_c	= roadway width between curbs or barriers if curbs are not used (ft.) (Article 10.39.2.1)	Δ_{DL}	= dead load camber at any point (in.) (Article 10.15.3)	+
+ W_n	= least net width of the flange or splice plate (in.) (Article 10.18.2.2.1)	Δ_m	= maximum value of Δ_{DL} (in.) (Article 10.15.3)	+
w	= length of a channel shear connector measured in a transverse direction on the flange of a girder (in.) (Article 10.38.5.1.1)	ϕ	= reduction factor (Articles 10.38.5.1.2, and Table 10.56A)	+
+ w	= unit weight of concrete (pcf) (Article 10.38.5.1.2)	ϕ	= longitudinal stiffener coefficient (Articles 10.39.4.3 and 10.51.5.4)	+
+ w	= width of flange between longitudinal stiffeners (in.) (Articles 10.39.4.3, 10.39.4.4, and 10.51.5.4)	ϕ_{bs}	= 0.8, reduction factor for block shear rupture strength (Article 10.19.4)	+
+ x	= subscript, represents the x-x axis (Article 10.54.2)	γ	= ratio of A_f to A_p (Article 10.18.1.2)	+
+ y	= subscript, represents the y-y axis (Article 10.54.2)	μ	= slip coefficient in a slip-critical joint (Articles 10.32.3.2 and 10.57.3)	+

10.1.3 Definition

The following terms are defined for general use in Section 10. Specialized definitions appear in individual Articles.

Allowable Design Strength – The capacity based on allowable stress in the case of SERVICE LOAD DESIGN METHOD, or the capacity based on design strength in the case of STRENGTH DESIGN METHOD.

Allowable Fatigue Stress Range – The maximum stress range that can be sustained without failure of the detail for a specified number of cycles.

Allowable Stress – The maximum stress permitted under full service load.

Anchor Rod – A fastener that is typically used to connect superstructure element to substructure and made from threaded rod or stud material.

Arch – A curved vertical structure in which the horizontal component of the force in the rib is resisted by a horizontal tie or its foundation.

Beam – A straight or curved horizontal structural member, primarily supporting transverse loads through flexure, shear and torsion actions. Generally, this term is used when the member is made of rolled shapes.

Beam-Column – A member subjected to a combination of axial force and bending moment.

Block Shear Rupture – Failure of a bolted web connection of coped beams or any tension connection when a portion of a plate tears out along the perimeter of the connecting bolts.

Bolt – A threaded fastener with a head, generally available in stock lengths up to about eight inches.

Bolt Assembly – The bolt, nut(s) and washer (s).

Bracing Member – A member intended to brace a main member, or part thereof, against lateral movement.

Charpy V-Notch Impact Requirement – The minimum energy required to be absorbed in a Charpy V-notch test conducted at a specified temperature.

Charpy V-notch Test – An impact test complying with the AASHTO T243M (ASTM A673M).

Clear Distance of Fasteners – The distance between edges of adjacent fastener holes.

Column – A vertical framed structural member primarily supporting axial compression loads.

Collapse Load – That load which can be carried by a structural member or structure when failure is imminent.

Compact Section – A section which is capable of developing the fully plastic stress distribution in flexure. The rotational capacity required to comply with analysis assumptions used in various articles of this section is

provided by satisfying various flange and web slenderness and bracing requirements.

Component – A constituent part of a structure or structural system.

Composite Beam/Girder – A beam/girder in which a steel beam/girder and concrete deck are interconnected by shear connectors and respond to force effects as a unit.

Cross Frame – Transverse truss framework connecting adjacent longitudinal flexural components.

Deck Truss – A truss system in which the roadway is at or above the elevation of the top chord of the truss.

Detail Category – A grouping of components and details having essentially the same fatigue resistance.

Diaphragm – A transverse flexural component connecting adjacent longitudinal flexural components.

Edge Distance of Fasteners – The distance perpendicular to the line of force between the center of a fastener hole and the edge of the component.

End Panel – The end section of a truss or girder.

Eyebar – A tension member with a rectangular section and enlarged ends for a pin connection.

Fastener – A rivet, bolt, threaded rod, or threaded stud that is used to fasten individual elements together.

Fatigue – The initiation and/or propagation of a crack due to repeated variation of normal stress with a tensile component.

Fatigue Design Life – The number of years that a detail is expected to resist the assumed traffic loads without fatigue cracking. In the development of these Specifications it has been taken as 75 years.

Fatigue Life – The number of repeated stress cycles that results in fatigue failure of a detail.

Finite Fatigue Life – The number of cycles to failure of a detail when the maximum probable stress range exceeds the constant amplitude fatigue threshold.

FCM – Fracture Critical Member – A tension member or a tension component of a flexural member (including those subject to reversal of stress) whose failure is expected to result in the collapse of the bridge

Fracture Toughness – A measure of a structural material or element to absorb energy without fracture, generally determined by the Charpy V-notch test.

Gage of Bolts – The distance between adjacent lines of bolts or the distance from the back of an angle or other shape to the first line of bolts.

Girder – A straight or curved structural horizontal member, primarily supporting transverse loads through flexure, shear and torsional actions. Generally, this term is used when the member is made of fabricated sections.

Grip – Distance between the nut and the bolt head.

Gusset Plate – Plate used to interconnect vertical,

+ diagonal and horizontal truss members at a panel point.
 + *Half-Through Truss Spans* – A truss system with the
 + roadway located somewhere between the top and bottom
 + chords and which precludes the use of a top lateral system.
 + *Horizontally Curved Beam/Girder* – A beam/girder
 + which is curved in plan.
 + *Hybrid Girder* – Fabricated steel girder with a web
 + that has a specified minimum yield strength which is
 + lower than one or both flanges.
 + *Inelastic Action* – A condition in which deformation is
 + not fully recovered upon removal of the load that pro-
 + duces it.
 + *Inelastic Redistribution* – The redistribution of inter-
 + nal force effects in a component or structure caused by
 + inelastic deformation at one or more sections.
 + *Interior Panel* – The interior section of a truss or girder
 + component.
 + *Lacing* – Plates or bars to connect main components of
 + a member.
 + *Lateral Bracing Component* – A component utilized
 + individually or as part of a lateral bracing system to
 + prevent lateral buckling of components and/or to resist
 + lateral loads.
 + *Load Path* – A succession of components and joints
 + through which a load is transmitted from its origin to its
 + destination.
 + *Longitudinally Loaded Weld* – Weld with applied load
 + parallel to the longitudinal axis of the weld.
 + *Main Member* – Any member on a critical path that
 + carries bridge gravity load. The loss of capacity of these
 + members would have serious consequences on the struc-
 + tural integrity.
 + *Net Tensile Stress* – The algebraic sum of two or more
 + stresses in which the net effect is tension.
 + *Non-Compact Section* – A section that can develop the
 + yield strength in compression elements before onset of local
 + buckling, but cannot resist inelastic local buckling at strain
 + levels required for a fully plastic stress distribution.
 + *Orthotropic Deck* – A deck made of steel plates
 + stiffened with open or closed steel ribs welded to the
 + underside.
 + *Permanent Deflection* – A type of inelastic deflection
 + which remains in a component or system after the load is
 + removed.
 + *Pitch of Bolts* – The distance along the line of force
 + between the centers of adjacent holes.
 + *Plate* – A flat steel plate product whose thickness
 + exceeds 0.25 in.
 + *Portal Frames* – End transverse truss bracing or
 + Vierendeel bracing that provides for stability and resists
 + wind or seismic loads.

Redistribution Moment – An internal moment caused
 by yielding in a continuous span bending component and
 held in equilibrium by external actions.

Redistribution of Moments – A process which results
 from formulation of inelastic deformation in continuous
 structures.

Redistribution Stress – The bending stress resulting
 from the redistribution moment.

Redundancy – The multiple load paths of a bridge
 which enables it to perform its design function in a
 damaged state.

Redundant Member – A member whose failure does
 not cause failure of the bridge.

Secondary Member – All members other than main
 member not designed to carry primary load.

Sheet – A flat rolled steel product whose thickness is
 between 0.006 in. and 0.25 in.

St. Venant Torsion – A torsional moment producing
 pure shear stresses on a cross-section in which plane
 sections remain plane.

Stress Range – The algebraic difference between
 extreme stresses resulting from the passage of a defined
 load.

Subpanel – A stiffened web panel divided by one or
 more longitudinal stiffeners.

Sway Bracing – Transverse vertical bracing between
 truss members.

Threaded Rod – An unheaded rod that is threaded its
 entire length, typically an “off-the-shelf” item.

Threaded Stud – An unheaded rod which is not threaded
 its entire length and typically threaded each end or one
 end.

Through Truss Spans – A truss system where the
 roadway is located near the bottom chord and which
 contains a top chord lateral system.

Tie Plates – Plates used to connect components of a
 member.

Transversely Loaded Weld – Weld with applied force
 perpendicular to the longitudinal axis of the weld.

Unbraced Length – Distance between brace points
 resisting the mode of buckling or distortion under consid-
 eration; generally, the distance between panel points or
 brace locations.

Warping Torsion – A twisting moment producing
 shear stress and normal stresses, and under which the
 cross-section does not remain plane.

Yield Strength – The stress at which a material exhibits
 a specified limiting deviation from the proportionality of
 stress to strain.

10.2 MATERIALS

10.2.1 General

These specifications recognize steels listed in the following subparagraphs. Other steels may be used; however, their properties, strengths, allowable stresses, and workability must be established and specified.

10.2.2 Structural Steels

Structural steels shall conform to the material designated in Table 10.2A. The modulus of elasticity of all grades of structural steel shall be assumed to be 29,000,000 psi and the coefficient of linear expansion 0.000065 per degree Fahrenheit. The shear modulus of elasticity shall be assumed to be 11,200,000 psi.

10.2.3 Steels for Pins, Rollers, and Expansion Rockers

Steels for pins, rollers, and expansion rockers shall conform to one of the designations listed in Table 10.2A and 10.2B, or shall be stainless steel conforming to ASTM A 240 or ASTM A 276 HNS 21800.

10.2.4 Fasteners

Fasteners may be carbon steel bolts (ASTM A 307); power-driven rivets, AASHTO M 228 Grades 1 or 2 (ASTM A 502 Grades 1 or 2); or high-strength bolts, AASHTO M 164 (ASTM A 325), AASHTO M 253 (ASTM A 490) or fasteners conforming to ASTM A354 and ASTM A449. Structural fasteners shall conform the material designated in Table 10.2C.

In the Standard Specifications of California Department of Transportation, the following fastener descriptions are defined: “Bolt” is ASTM A307; “HS Bolt” is ASTM A325; “Threaded Rod” is ASTM A307 Grade C. “HS Threaded Rod” is ASTM A449. “Thread Stud” is ASTM A307 Grade C. “HS Threaded Stud” is ASTM A449; tensioning requirements only apply to A325 and A490 bolts; and “Bolt” is a generic term that applies to threaded rods, threaded studs, and anchor rods. The provisions and specifications in ASTM A325, A490, and A307 Grades A and B, are for headed bolts only and do not apply to threaded rods and studs. While ASTM A449 or A354 bolts seem to be the equal of ASTM A325 or A490 for certain diameters and grades, there are differences in the

requirements for inspection and quality assurance, and heavy-hex head and nut dimensions. The tensioning requirements in the Standard Specifications only apply to ASTM A325 and A490 bolts.

10.2.5 Weld Metal

Weld metal shall conform to the current requirements of the *ANSI/AASHTO/AWS D1.5 Bridge Welding Code*.

TABLE 10.2A Minimum Material Properties – Structural Steel

AASHTO Designation ^{a,c}	M 270 Grade 36	M 270 Grade 50	M 270 Grade 50W		M 270 Grades 100/100W	
Equivalent ASTM Designation ^c	A 709 Grade 36	A 709 Grade 50	A 709 Grade 50W	A 709 Grade HPS 70W	A 709 Grades 100/100W ^b	
Thickness of Plates	Up to 4 in. incl. ^e	Up to 4 in. incl.	Up to 4 in. incl.	Up to 4 in. incl.	Up to 2½ in. incl.	Over 2½ in. to 4 in. incl.
Shapes ^d	All Groups ^c	All Groups	All Groups	Not Applicable	Not Applicable	Not Applicable
Minimum Tensile Strength, F_u , psi	58,000	65,000	70,000	90,000	110,000	100,000
Minimum Yield Strength, F_y , psi	36,000	50,000	50,000	70,000	100,000	90,000

^a Except for the mandatory notch toughness and weldability requirements, the ASTM designations are similar to the AASHTO designations. Steels meeting the AASHTO requirements are prequalified for use in welded bridges.

^b Quenched and tempered alloy steel structural shapes and seamless mechanical tubing meeting all mechanical and chemical requirements of A 709 Grades 100/100W, except that the specified maximum tensile strength may be 140,000 psi for structural shapes and 145,000 psi for seamless mechanical tubing, shall be considered as A 709 Grades 100/100W.

^c M 270 Grade 36 and A 709 Grade 36 are equivalent to M 183 and A 36.

M 270 Grade 50 and A 709 Grade 50 are equivalent to M 223 Grade 50 and A 572 Grade 50.

M 270 Grade 50W and A 709 Grade 50W are equivalent to M 222 and A 588.

M 270 Grade 70W and A 709 Grade 70W are equivalent to A 852.

M 270 Grades 100/100W and A 709 Grades 100/100W are equivalent to M 244 and A 514.

ASTM A 709, Grade HPS 70W replaces AASHTO M 270, Grade 70W. The intent of this replacement is to encourage the use of HPS steel over conventional bridge steels due to its enhanced properties. AASHTO M 270, Grade 70W is still available, but should be used only with the owners approval.

^d Groups 1 and 2 include all shapes except those in Groups 3, 4, and 5. Group 3 includes L-shapes over ¾ inch in thickness. HP shapes over 102 pounds/foot, and the following W shapes:

Designations: W36 x 230 to 300 included

W33 x 200 to 240 included

W14 x 142 to 211 included

W12 x 120 to 190 included

Group 4 includes the following W shapes: W14 x 219 to 550 included

Group 5 includes the following W shapes: W14 x 605 to 730 included

For breakdown of Groups 1 and 2 see ASTM A 6.

^e For nonstructural applications or bearing assembly components over 4 in. thick, use AASHTO M 270 Grade 36 (ASTM A 270 Grade 36).

TABLE 10.2B Minimum Material Properties – Pins, Rollers, and Rockers

Expansion rollers shall be not less than 4 inches in diameter			
+ + AASHTO Designation with Size Limitations	M 102 to 20 in. in dia.	M 102 to 10 in. in dia.	M 102 to 20 in. in dia.
+ + ASTM Designation Grade or Class	A 668 Class D	A 668 Class F	A 668 ^b Class G
+ + Minimum Yield Strength F_y , psi	37,500	50,000	50,000

^b May substitute rolled material of the same properties.

TABLE 10.2C Minimum Material Properties – Fasteners

Type	ASTM Design	Availability			Strength	
		Material Type ^a	Grade	Diameter (in.)	Minimum Yield F_y (psi)	Minimum Tensile F_u (psi)
Unheaded Rod and Stud Material (only)	A36	C	-	to 8	36,000	58,000
	A572	HSLA	42	to 2	42,000	60,000
			50	to 6	50,000	65,000
	A588	HSLA ACR	-	to 4	50,000	70,000
				over 4 to 5	46,000	67,000
				over 5 to 8	42,000	63,000
	A307	C	C	-	36,000	58,000
Rivets	A502	C	1	-	NA	60,000 ^d
		HSLA	2			80,000 ^d
		HSLA, ACR	3			80,000 ^d
Headed Bolt or Unheaded Rod Material	A354	A, QT	BD	$\frac{1}{4}$ to $2\frac{1}{2}$	130,000	150,000
				over $2\frac{1}{2}$ to 4	115,000	140,000
			BC	$\frac{1}{4}$ to $2\frac{1}{2}$	109,000	125,000
				over $2\frac{1}{2}$ to 4	99,000	115,000
	A449	C, QT	-	$\frac{1}{4}$ to 1	92,000	120,000
				$1\frac{1}{8}$ to $1\frac{1}{2}$ $1\frac{3}{4}$ to 3	81,000 58,000	105,000 90,000
Headed Bolt Material (only)	A307	C	A, B	to 4	NA	60,000
	A325 ^{b,c}	C, QT	-	$\frac{1}{2}$ to 1	92,000	120,000
				$1\frac{1}{8}$ to $1\frac{1}{2}$	81,000	105,000
	A490 ^{b,c}	A, QT	-	$\frac{1}{2}$ to $1\frac{1}{2}$	130,000	150,000

^a A = Alloy Steel

ACR = Atmospheric-Corrosion-Resistant Steel

C = Carbon Steel

HSLA = High-Strength Low-Alloy Steel

QT = Quenched and Tempered Steel

^b Available with weathering (atmospheric corrosion resistance) characteristics comparable to ASTM A242 and A588 Steels.

^c Threaded rod material with properties meeting ASTM A325, A490, and A449 specifications may be obtained with the use of an appropriate steel (such as ASTM A193, grade B7), quenched and tempered after fabrication.

^d ASTM Specifications do not specify tensile strength for A502 rivets. A reasonable lower bound estimate $F_u = 60,000$ psi for Grade 1 and 80,000 for Grades 2 and 3 are a reasonable lower bound estimate (See Kulak, Fisher and Struik, Guide to Design for Bolted and Riveted Joints, Second Edition, John Wiley & Sons, 1987, New York, NY).



10.2.6 Cast Steel, Ductile Iron Castings, Malleable Castings and Cast Iron

10.2.6.1 Cast Steel and Ductile Iron

Cast steel shall conform to specifications for Steel Castings for Highway Bridges, AASHTO M 192 (ASTM A 486); Mild-to-Medium-Strength Carbon-Steel Castings for General Application, AASHTO M 103 (ASTM A 27); and Corrosion-Resistant Iron-Chromium, Iron-Chromium-Nickel and Nickel-Based Alloy Castings for General Application, AASHTO M 163 (ASTM A 743). Ductile iron castings shall conform to ASTM A 536.

10.2.6.2 Malleable Castings

Malleable castings shall conform to specifications for
+ Malleable Iron Castings, ASTM A 47, Grade 35018
+ (specified minimum yield strength 35,000 psi).

10.2.6.3 Cast Iron

Cast iron castings shall conform to specifications for Gray Iron Castings, AASHTO M 105, Class 30.

**Part B
Design Details**

10.3 REPETITIVE LOADING AND TOUGHNESS CONSIDERATIONS

+ **10.3.1 Allowable Fatigue Stress Ranges**

Members and fasteners subject to repeated variations or reversals of stress shall be designed so that the maximum stress does not exceed the basic allowable stresses given in Article 10.32 and that the actual range of stress does not exceed the allowable fatigue stress range given in Table 10.3.1A for the appropriate type and location of material given in Table 10.3.1B and shown in Figure 10.3.1C. For members with shear connectors provided throughout their entire length that also satisfy the provisions of Article 10.38.4.3, the range of stress may be computed using the composite section assuming the concrete deck to be fully effective for both positive and negative moment.

For unpainted weathering steel, A709, all grades, the values of allowable fatigue stress range, Table 10.3.1A, as modified by footnote d, are valid only when the design and details are in accordance with the FHWA *Technical Advisory on Uncoated Weathering Steel in Structures*, dated October 3, 1989.

TABLE 10.3.1A Allowable Fatigue Stress Range

Redundant Load Path Structures*				
Category (See Table 10.3.1B)	Allowable Range of Stress, F_{sr} (psi) ^a			
	For 100,000 Cycles	For 500,000 Cycles	For 2,000,000 Cycles	For over 2,000,000 Cycles
A	63,000 49,000 ^d	37,000 29,000 ^d	24,000 18,000 ^d	24,000 16,000 ^d
B	49,000	29,000	18,000	16,000
B'	39,000	23,000	14,500	12,000
C	35,500	21,000	13,000	10,000 12,000 ^b
D	28,000	16,000	10,000	7,000
E	22,000	13,000	8,000	4,500
E'	16,000	9,200	5,800	2,600
F	15,000	12,000	9,000	8,000

Nonredundant Load Path Structures				
Category (See Table 10.3.1B)	Allowable Range of Stress, F_{sr} (psi) ^a			
	For 100,000 Cycles	For 500,000 Cycles	For 2,000,000 Cycles	For over 2,000,000 Cycles
A	50,000 39,000 ^d	29,000 23,000 ^d	24,000 16,000 ^d	24,000 16,000 ^d
B	39,000	23,000	16,000	16,000
B'	31,000	18,000	11,000	11,000
C	28,000	16,000	10,000 12,000 ^b	9,000 11,000 ^b
D	22,000	13,000	8,000	5,000
E ^c	17,000	10,000	6,000	2,300
E'	12,000	7,000	4,000	1,300
F	12,000	9,000	7,000	6,000

* Structure types with multi-load paths where a single fracture in a member cannot lead to the collapse. For example, a simply supported single span multi-beam bridge or a multi-element eye bar truss member has redundant load paths.

^a The range of stress is defined as the algebraic difference between the maximum stress and the minimum stress. Tension stress is considered to have the opposite algebraic sign from compression stress.

^b For transverse stiffener welds on girder webs or flanges.

^c Partial length welded cover plates shall not be used on flanges more than 0.8 inches thick for nonredundant load path structures.

^d For unpainted weathering steel, A 709, all grades, when used in conformance with the FHWA *Technical Advisory on Uncoated Weathering Steel in Structures*, dated October 3, 1989.

TABLE 10.3.1B

General Condition	Situation	Stress Kind of Stress	Illustrative Category (See Table 10.3.1A)	Example (See Figure 10.3.1C)	
Plain Member	Base metal with rolled or cleaned surface. Flame cut edges with ANSI smoothness of 1,000 or less.	T or Rev ^a	A	1, 2	
Built-Up Members	Base metal and weld metal in members of built-up plates or shapes (without attachments) connected by continuous full penetration groove weld (with backing bars removed) or by continuous fillet weld parallel to the direction of applied stress.	T or Rev	B	3, 4, 5, 7	
	Base metal and weld metal in members of built-up plates or shapes (without attachments) connected by continuous full penetration groove welds with backing bars not removed, or by continuous partial penetration groove welds parallel to the direction of applied stress.	T or Rev	B'	3, 4, 5, 7	
	Calculated flexural stress at the toe of transverse stiffener welds on girder webs or flanges.	T or Rev	C	6	
	Base metal at ends of partial length welded coverplates with high-strength bolted slip-critical end connections. (See Note f.)	T or Rev	B	22	
	Base metal at ends of partial length welded coverplates narrower than the flange having square or tapered ends, with or without welds across the ends, or wider than flange with welds across the ends:				
	(a) Flange thickness ≤ 0.8 inches (b) Flange thickness > 0.8 inches Base metal at ends of partial length welded coverplates wider than the flange without welds across the ends.	T or Rev	E	7	
T or Rev	E'	7	T or Rev	E'	7
Groove Welded Connections	Base metal and weld metal in or adjacent to full penetration groove weld splices of rolled or welded sections having similar profiles when welds are ground flush with grinding in the direction of applied stress and weld soundness established by nondestructive inspection.	T or Rev	B	8, 10	
	Base metal and weld metal in or adjacent to full penetration groove weld splices with 2 foot radius transitions in width, when welds are ground flush with grinding in the direction of applied stress and weld soundness established by nondestructive inspection.	T or Rev	B	13	
	Base metal and weld metal in or adjacent to full penetration groove weld splices at transitions in width or thickness, with welds ground to provide slopes no steeper than 1 to 2 ¹ / ₂ , with grinding in direction of the applied stress, and weld soundness established by non-destructive inspection:				
	(a) AASHTO M 270 Grades 100/100W (ASTM A 709) base metal (b) Other base metal	T or Rev	B'	11	+
<i>continue next page</i>		T or Rev	B	11	+

TABLE 10.3.1B (continued)

General Condition	Situation	Kind of Stress	Stress Category (See Table 10.3.1A)	Illustrative Example (See Figure 10.3.1C)
Groove Welded Connections (continued)	Base metal and weld metal in or adjacent to full penetration groove weld splices, with or without transitions having slopes no greater than 1 to 2 ¹ / ₂ , when reinforcement is not removed and weld soundness is established by nondestructive inspection.	T or Rev	C	8, 10, 11
Groove Welded Attachments— Longitudinally Loaded ^b	Base metal adjacent to details attached by full or partial penetration groove welds when the detail length, <i>L</i> , in the direction of stress, is less than 2 in.	T or Rev	C	6
Fillet Welded Connections	Base metal at intermittent fillet welds. Shear stress on throat of fillet welds.	T or Rev Shear	E F	— 9
Fillet Welded Attachments— Longitudinally Loaded ^{b, c, e}	Base metal adjacent to details attached by fillet welds with length, <i>L</i> , in the direction of stress, less than 2 inches and stud-type shear connectors. Base metal adjacent to details attached by fillet welds with length, <i>L</i> , in the direction of stress greater than 12 times the plate thickness or greater than 4 inches:	T or Rev	C	18,20
	(a) Detail thickness < 1.0 in.	T or Rev	E	7,9
	(b) Detail thickness 1.0 in.	T or Rev	E	7,9
Mechanically Fastened Connections	Base metal at gross section of high strength bolted slip resistant connections, except axially loaded joints which induce out-of-plane bending in connecting materials. Base metal at net section of high strength bolted bearing-type connections. Base metal at net section of riveted connections.	T or Rev T or Rev T or Rev	B B D	21 21 21
Eyebar or Pin Plates	Base metal at the net section of eyebar head, or pin plate Base metal in the shank of eyebars, or through the gross section of pin plates with:	T T T	E A B	23,24 23,24 23,24

See next page for footnotes

Footnotes for Table 10.3.1B

- a "T" signifies ranges in tensile stress only, "Rev" signifies a range of stress involving both tension and compression during a stress cycle.
- b "Longitudinally Loaded" signifies direction of applied stress is parallel to the longitudinal axis of the weld. "Transversely Loaded" signifies direction of applied stress is perpendicular to the longitudinal axis of the weld.
- c Transversely loaded partial penetration groove welds are prohibited.
- d Allowable fatigue stress range on throat of fillet welds transversely loaded is a function of effective throat and plate thickness. (See Frank and Fisher, Journal of the Structural Division, ASCE, Vol. 105, No. ST9, September 1979.)

$$S_r = S_r^c \left(\frac{0.06 + 0.79H / t_p}{1.1t_p^{1/6}} \right)$$

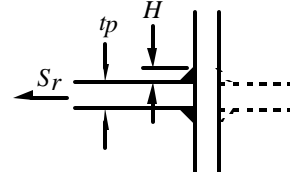

- where S_r^c is equal to the allowable stress range for Category C given in Table 10.3.1A. This assumes no penetration at the weld root.
- e Gusset plates attached to girder flange surfaces with only transverse fillet welds are prohibited.
- f See Wattar, Albrecht and Sahli, Journal of Structural Engineering, ASCE, Vol. III, No. 6, June 1985, pp. 1235-1249.

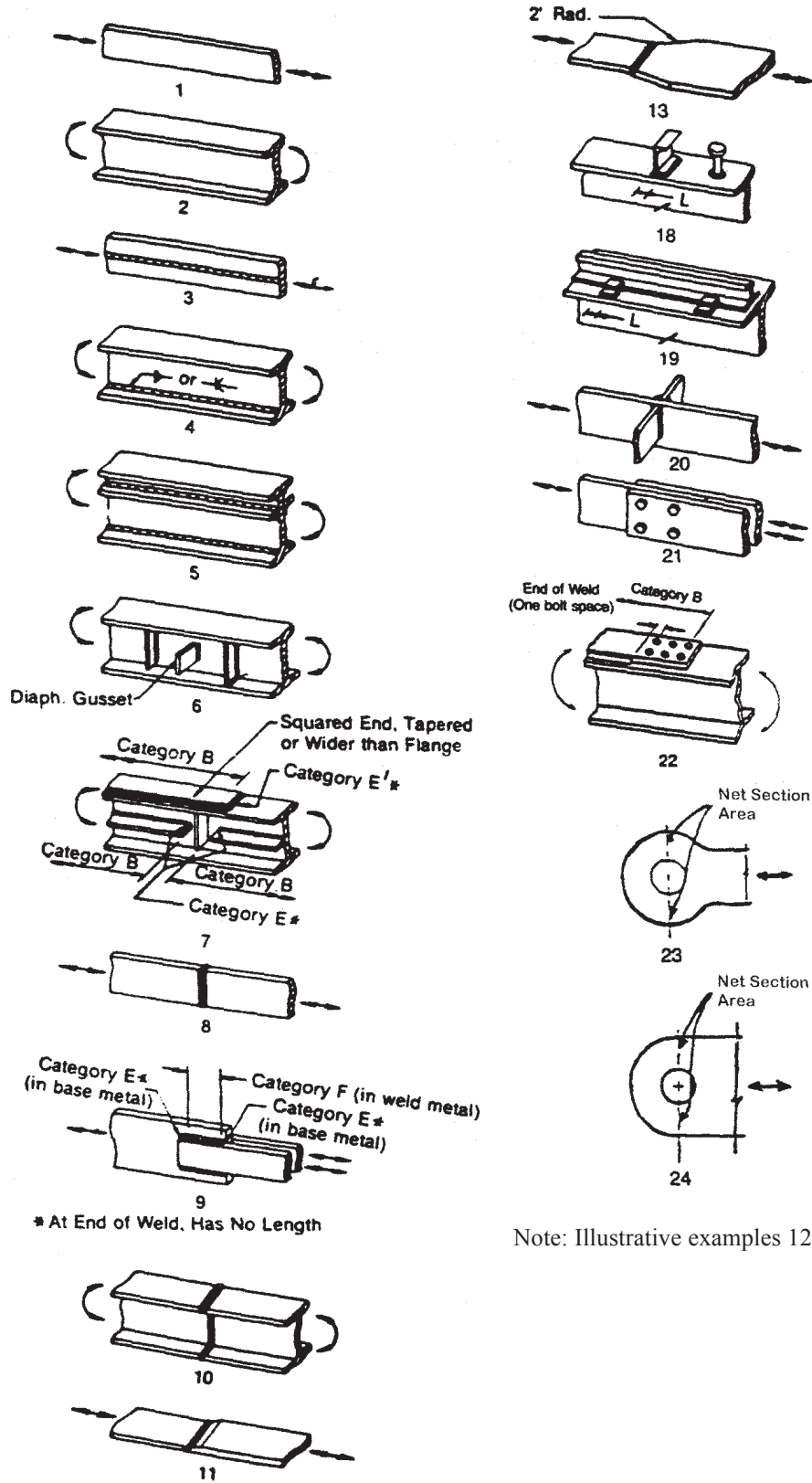

Note: Illustrative examples 12, 14 – 17 are deleted.

FIGURE 10.3.1C Illustrative Examples



TABLE 10.3.2A Stress Cycle

Main (Longitudinal) Load Carrying Members					
Type of Road	Case	ADTT ^a	Truck Loading	Lane Loading ^b	Permit Loading
Freeways, Expressways, Major Highways, and Streets	I	2,500 or more	2,000,000 ^c	500,000	100,000
Freeways, Expressways, Major Highways, and Streets	II	Less than 2,500	500,000	100,000	—
Other Highways and Streets not included in Case I or II	III	—	100,000	100,000	—

Transverse Members and Details Subjected to Wheel Loads						
Type of Road	Case	ADTT ^a	Longitudinal Span			
			≤ 40 Feet	> 40 Feet		
			Truck Loading	Truck Loading	Lane Loading	Permit Loading
Freeways, Expressways, Major Highways, and Streets	I	2,500 or more	Over 2,000,000	2,000,000	500,000	100,000
Freeways, Expressways, Major Highways, and Streets	II	Less than 2,500	Over 2,000,000	500,000	100,000	—
Other Highways and Streets	III	—	2,000,000	100,000	100,000	—

^a Average Daily Truck Traffic (one direction).

^b Longitudinal members should also be checked for truck loading.

^c Members shall also be investigated for “over 2 million” stress cycles produced by placing a single truck on the bridge distributed to the girders as designated in Article 3.23.2.

Main load carrying components subjected to tensile force that may be considered nonredundant load path members—that is, where failure of a single element could cause collapse—shall be designed for the allowable stress ranges indicated in Table 10.3.1A for Nonredundant Load Path Structures. Examples of nonredundant load path members are flange and web plates in one or two girder bridges, main one-element truss members, hanger plates, and caps at single or two-column bents.

+ See AASHTO “Guide Specifications for Fracture
+ Critical Non-Redundant Steel Bridge Members.”

10.3.2 Load Cycles

10.3.2.1 The number of cycles of maximum stress range to be considered in the design shall be selected from Table 10.3.2A unless traffic and loadometer surveys or other considerations indicate otherwise.

+ For new structures and widenings, the number of
+ stress cycles shall be based on Case I.

+ **10.3.2.2** Allowable fatigue stress ranges shall apply
+ to those Group Loadings that include live load or
+ wind load.

10.3.2.3 The number of cycles of stress range to be considered for wind loads in combination with dead loads, except for structures where other considerations indicate a substantially different number of cycles, shall be 100,000 cycles.

10.3.3 Charpy V-Notch Impact Requirements

+ **10.3.3.1** Main load carrying member components
+ subjected to tensile force require supplemental impact
+ properties.

10.3.3.2 These impact requirements vary depending on the type of steel, type of construction, welded or mechanically fastened, and the average minimum service temperature to which the structure may be subjected.*** Table 10.3.3A contains the temperature zone designations.

+ The Standard Specifications of the California Department
+ of Transportation, Section 55, lists the required
+ minimum impact values for Zone 2.

*** The basis and philosophy used to develop these requirements are given in a paper entitled “The Development of AASHTO Fracture-Toughness requirements for Bridge Steels” by John M. Barsom, February 1975, available from the American Iron and Steel Institute, Washington, DC.

TABLE 10.3.3A Temperature Zone Designation for Charpy V-Notch Impact Requirements

Minimum Service Temperature	Temperature Zone Designation
0°F and above	1
-1°F to -30°F	2
-31°F to -60°F	3

10.3.3.3 Components requiring mandatory impact properties shall be designated on the drawings and the appropriate Charpy V-notch impact values shall be designated in the contract documents. +

10.3.3.4 M 270 Grades 100/100W steel shall be supplied to Zone 2 requirements as a minimum.

10.3.4 Shear

When longitudinal beam or girder members in bridges designed for Case 1 roadways are investigated for “over 2 million” stress cycles produced by placing a single truck on the bridge (see footnote (c) of Table 10.3.2A), the total shear force in the beam or girder under this single-truck loading shall be limited to $0.58 F_y D_t_w C$. The constant C , the ratio of the buckling shear stress to the shear yield stress is defined in Article 10.34.4.2 or Article 10.48.8.1. +

10.3.5 Loading

The fatigue loading shall be at service load and shall include permit loading. The load combination for permit loading shall be a P load with a $\beta = 1.15$ and an associated HS loading. The load shall be calculated according to footnote (f) in Table 3.23.1. +

10.4 EFFECTIVE LENGTH OF SPAN

For the calculation of stresses, span lengths shall be assumed as the distance between centers of bearings or other points of support.

10.5 DEPTH RATIOS

10.5.1 For noncomposite beams or girders, the ratio of the depth of girder to the length of span preferably should not be less than 0.04. +

- + **10.5.2** For composite girders, the ratio of the overall depth of girder (concrete slab plus steel girder) to the length of span preferably should not be less than 0.045 for simple spans and 0.04 for continuous spans.

10.5.3 For trusses the ratio of depth to length of span preferably should not be less than 0.1.

- + **10.5.4** Deleted

10.5.5 The foregoing requirements as they relate to beam or girder bridges may be exceeded at the discretion of the designer.*

10.6 DEFLECTION

10.6.1 The term “deflection” as used herein shall be the deflection computed in accordance with the assumption made for loading when computing the stress in the member.

- + **10.6.2** Members having simple or continuous spans preferably should be designed so that the ratio of the deflection to the length of the span due to service live load plus impact shall not exceed $1/800$, except on bridges in urban areas used in part by pedestrians whereon the ratio preferably shall not exceed $1/1000$.

- + **10.6.3** The ratio of the deflection to the cantilever arm length due to service live load plus impact preferably should be limited to $1/300$ except for the case including pedestrian use, where the ratio preferably should be $1/375$.

- + **10.6.4** When spans have cross-bracing or diaphragms sufficient in depth or strength to ensure lateral distribution of loads, the deflection may be computed for the standard H or HS loading considering all beams or stringers as acting together and having equal deflection.

10.6.5 The moment of inertia of the gross cross-sectional area shall be used for computing the deflections of beams and girders. When the beam or girder is a part of a composite member, the service live load may be considered as acting upon the composite section.

10.6.6 The gross area of each truss member shall be used in computing deflections of trusses. If perforated plates are used, the effective area shall be the net volume divided by the length from center to center of perforations.

* For consideration to be taken into account when exceeding these limitations, reference is made to “Bulletin No. 19, Criteria for the Deflection of Steel Bridges,” available from the American Iron and Steel Institute, Washington, D.C.

10.6.7 The foregoing requirements as they relate to beam or girder bridges may be exceeded at the discretion of the designer.*

10.7 LIMITING LENGTHS OF MEMBERS

10.7.1 For compression members, the slenderness ratio, KL/r , shall not exceed 120 for main members, or those in which the major stresses result from dead or live load, or both; and shall not exceed 140 for secondary members, or those whose primary purpose is to brace the structure against lateral or longitudinal force, or to brace or reduce the unbraced length of other members, main or secondary.

10.7.2 In determining the radius of gyration, r , for the purpose of applying the limitations of the KL/r ratio, the area of any portion of a member may be neglected provided that the strength of the member as calculated without using the area thus neglected and the strength of the member as computed for the entire section with the KL/r ratio applicable thereto, both equal or exceed the computed total force that the member must sustain.

10.7.3 The radius of gyration and the effective area of a member containing perforated cover plates shall be computed for a transverse section through the maximum width of perforation. When perforations are staggered in opposite cover plates the cross-sectional area of the member shall be considered the same as for a section having perforations in the same transverse plane.

10.7.4 The unbraced length, L , shall be assumed as follows:

For the compression chords of trusses, the length between panel points laterally supported as indicated under Article 10.16.12; for other members, the length between panel point intersections or centers of braced points or centers of end connections.

10.7.5 For tension members, except rods, eyebars, cables, and plates, the ratio of unbraced length to radius of gyration shall not exceed 200 for main members, shall not exceed 240 for bracing members, and shall not exceed 140 for main members subject to a reversal of stress.

10.8 MINIMUM THICKNESS OF METAL

+ **10.8.1** The plate thickness of structural steel including
 + bracing, cross frames, and all types of gusset plates, shall
 + be not less than $5/16$ inch. The web thickness of rolled
 + beams or channels shall be not less than 0.23 inches. The
 + thickness of closed ribs in orthotropic decks, fillers, and
 + in railings, shall be not less than $3/16$ inch.

10.8.2 Where the metal will be exposed to marked
 corrosive influences, it shall be increased in thickness or
 specially protected against corrosion.

10.8.3 It should be noted that there are other
 provisions in this section pertaining to thickness for
 fillers, segments of compression members, gusset plates,
 etc. As stated above, fillers need not be $5/16$ inch minimum.

10.8.4 For compression members, refer to "Trusses"
 (Article 10.16).

+ **10.8.5** For flexural members, refer to "Plate Girders"
 (Article 10.34).

+ **10.8.6** For stiffeners and outstanding legs of angles,
 + etc., refer to relevant Articles 10.10, 10.34, 10.37, 10.48,
 + 10.51 and 10.55.

+ 10.9 EFFECTIVE NET AREA FOR + TENSION MEMBERS

+ **10.9.1** When a tension load is transmitted directly to
 + each of the cross-sectional elements by fasteners or
 + welds, the effective net area A_e is equal to the net area A_n .

+ **10.9.2** When a tension load is transmitted by bolts or
 + rivets through some but not all of the cross-sectional
 + elements of the member, the effective net area A_e shall be
 + calculated as:

$$A_e = UA \quad (10-1a)$$

+ where:

- + A = area as defined below (in.²)
- + U = reduction coefficient
- + = $1 - (x/L)$ 0.9 or as defined in (c) and (d)
- + x = connection eccentricity (in.); for rolled or built-
 + up shapes, it is referred to the center of gravity
 + of the material lying on either side of the

centerline of symmetry of the cross-section, as
 shown in Fig. 10.9.2A

L = length of connection in the directions of loading
 (in.)

Larger values of U are permitted to be used when
 justified by tests or other rational criteria.

(a) When the tension load is transmitted only by
 bolts or rivets:

$$A = A_n = \text{net area of member (in.}^2\text{)} \quad +$$

(b) When the tension load is transmitted only by
 longitudinal welds to other than a plate member or by
 longitudinal welds in combination with transverse welds:

$$A = A_g = \text{gross area of member (in.}^2\text{)} \quad +$$

(c) When the tension load is transmitted only by
 transverse welds:

$$A = \text{area of directly connected elements (in.}^2\text{)} \quad +$$

$$U = 1.0 \quad +$$

(d) When the tension load is transmitted to a plate
 by longitudinal welds along both edges at the end of the
 plate for $L_w > W$

$$A = \text{area of plate (in.}^2\text{)} \quad +$$

for $L_w \leq 2W$		$U = 1.0$	+
for $2W > L_w$	$1.5W$	$U = 0.87$	+
for $1.5W > L_w$	W	$U = 0.75$	+

where: +

L_w = length of weld (in.) +
 W = plate width (distance between welds) (in.) +

10.9.3 Deleted +

10.9.4 Deleted +

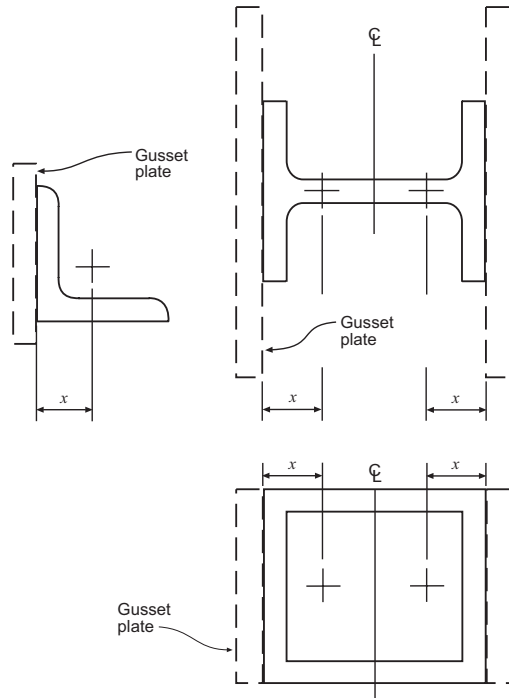

FIGURE 10.9.2A Determination of x

10.10 OUTSTANDING LEGS OF ANGLES

The widths of outstanding legs of angles in compression (except where reinforced by plates) shall not exceed the following:

In main members carrying axial compression load, 12 times the thickness.

In bracing and other secondary members, 16 times the thickness.

For other limitations see Article 10.35.2.

10.11 EXPANSION AND CONTRACTION

In all bridges, provisions shall be made in the design to resist thermal stresses induced, or means shall be provided for movement caused by temperature changes. Provisions shall be made for changes in length of span resulting from live loads. In spans more than 300 feet long, allowance shall be made for expansion and contraction in the floor. The expansion end shall be secured against lateral movement.

10.12 MEMBERS

10.12.1 Flexural Members

Flexural members shall be designed using the elastic section modulus except when utilizing compact sections under Strength Design as specified in Articles 10.48.1, 10.50.1.1, and 10.50.2.1. In determining flexural strength, the gross section shall be used, except that if more than 15 percent of each flange area is removed, that amount removed in excess of 15 percent shall be deducted from the gross area. In no case shall the design tensile stress on the net section exceed $0.50 F_u$, when using service load design method or $1.0 F_u$, when using strength design method, where F_u equals the specified minimum tensile strength of the steel, except that for M 270 Grades 100/100W steels the design tensile stress on the net section shall not exceed $0.46 F_u$ when using the service load design method.

10.12.2 Compression Members

The strength of compression members connected by high-strength bolts and rivets shall be determined by the gross section.

10.12.3 Tension Members

The strength of tension members connected by bolts or rivets shall be determined by the gross section unless the net section area is less than 85 percent of the corresponding gross area, in which case that amount removed in excess of 15 percent shall be deducted from the gross area. In no case shall the design tensile stress on the net section exceed $0.50 F_u$, when using service load design method or $1.0 F_u$, when using strength design method, where F_u equals the specified minimum tensile strength of the steel, except that for M 270 Grades 100/100W steels the design tensile stress on the net section shall not exceed $0.46 F_u$ when using the service load design method.

10.13 COVER PLATES

10.13.1 The length of any cover plate added to a rolled beam shall be not less than $(2d + 36)$ in. where (d) is the depth of the beam (in.).

10.13.2 Partial length welded cover plates shall not be used on flanges more than 0.8 inches thick for nonredundant load path structures subjected to repetitive loadings that produce tension or reversal of stress in the member.

10.13.3 The maximum thickness of a single cover plate on a flange shall not be greater than 2 times the thickness of the flange to which the cover plate is attached. The total thickness of all cover plates should not be greater than $2\frac{1}{2}$ times the flange thickness.

10.13.4 Any partial length welded cover plate shall extend beyond the theoretical end by the terminal distance, and it shall extend to a section where the stress range in the beam flange is equal to the allowable fatigue stress range for base metal adjacent to or connected by fillet welds. The theoretical end of the cover plate, when using service load design methods, is the section at which the stress in the flange without that cover plate equals the allowable service load stress, exclusive of fatigue considerations. When using strength design methods, the theoretical end of the cover plate is the section at which the flange strength without that cover plate equals the required strength for the design loads, exclusive of fatigue requirements. The terminal distance is two times the nominal cover plate width for cover plates not welded across their ends, and $1\frac{1}{2}$ times for cover plates welded across their ends. The width at ends of tapered cover plates shall be not less than 3 inches. The weld connecting the cover plate to the flange in its terminal distance shall be continuous and of sufficient size to develop a total force of not less than the computed force in the cover plate at its theoretical end. All welds connecting cover plates to beam flanges shall be continuous and shall not be smaller than the minimum size permitted by Article 10.23.2.2.

10.13.5 Any partial length end-bolted cover plate shall extend beyond the theoretical end by the terminal distance equal to the length of the end-bolted portion, and the cover plate shall extend to a section where the stress range in the beam flange is equal to the allowable fatigue stress range for base metal at ends of partial length welded cover plates with high-strength bolted, slip-critical end connections (Table 10.3.1B). Beams with end-bolted cover plates shall be fabricated in the following sequence: drill holes; clean faying surfaces; install bolts; weld. The theoretical end of the end-bolted cover plate is determined in the same manner as that of a welded cover plate, as specified in Article 10.3.4. The bolts in the slip-critical

connections of the cover plate ends to the flange, shall be of sufficient numbers to develop a total force of not less than the computed force in the cover plate at the theoretical end. The slip resistance of the end-bolted connection shall be determined in accordance with Article 10.32.3.2 for service load design, and 10.56.1.4 for load factor design. The longitudinal welds connecting the cover plate to the beam flange shall be continuous and stop a distance equal to one bolt spacing before the first row of bolts in the end-bolted portion.

10.14 CAMBER

Girder should be cambered to compensate for dead load deflections and vertical curvature required by profile grade.

10.15 HEAT-CURVED ROLLED BEAMS AND WELDED PLATE GIRDERS

10.15.1 Scope

This section pertains to rolled beams and welded I-section plate girders heat-curved to obtain a horizontal curvature. Steels that are manufactured to a specified minimum yield strength greater than 50,000 psi, except for Grade HPS 70W Steel, shall not be heat-curved.

10.15.2 Minimum Radius of Curvature

10.15.2.1 For heat-curved beams and girders, the horizontal radius of curvature measured to the centerline of the girder web shall not be less than 150 feet and shall not be less than the larger of the values calculated (at any and all cross sections throughout the length of the girder) from the following two equations:

$$R = \frac{440 b D}{\sqrt{F_y} \mathcal{Y} t_w} \quad (10-1)$$

$$R = \frac{7,500,000 b}{F_y} \quad (10-2)$$

where:

F_y = specified minimum yield strength of the web (psi)

- + y = ratio of the total cross-sectional area to the cross-sectional area of both flanges
- + b = widest flange width (in.)
- + D = clear distance between flanges (in.)
- + t_w = web thickness (in.)
- + R = horizontal radius of curvature (in.)

10.15.2.2 In addition to the above requirements, the radius shall not be less than 1,000 feet when the flange thickness exceeds 3 inches or the flange width exceeds 30 inches.

10.15.3 Camber

- + To compensate for possible loss of camber of heat-curved girders in service as residual stresses dissipate, the amount of camber, Δ (in.) at any section along the length L of the girder shall be equal to:

$$\Delta = \frac{\Delta_{DL}}{\Delta_M} (\Delta_M + \Delta_R) \quad (10-3)$$

- +
$$\Delta_R = \frac{0.02L^2F_y}{EY_o} \left(\frac{1,000 - R}{850} \right) \geq 0$$

where:

- + Δ_{DL} = camber at any point along the length L calculated by usual procedures to compensate for deflection due to dead loads or any other specified loads (in.)
- + Δ_M = maximum value of Δ_{DL} within the length L (in.)
- + E = modulus of elasticity of steel (psi)
- + F_y = specified minimum yield strength of girder flange (psi)
- + Y_o = distance from the neutral axis to the extreme outer fiber (in.) (maximum distance for non-symmetrical sections)
- + R = radius of curvature (ft.)
- + L = span length for simple spans or for continuous spans, the distance between a simple end support and the dead load contraflexure point, or the distance between points of dead load contraflexure (in.)

Camber loss between dead load contraflexure points adjacent to piers is small and may be neglected.

Note: Part of the camber loss is attributable to construction loads and will occur during construction of the bridge; total camber loss will be complete after several months of in-service loads. Therefore, a portion of the camber increase (approximately 50 percent) should be included in the bridge profile. Camber losses of this nature (but generally smaller in magnitude) are also known to occur in straight beams and girders.

10.16 TRUSSES

10.16.1 General

10.16.1.1 Component parts of individual truss members may be connected by welds, rivets, or high-strength bolts.

10.16.1.2 Preference should be given to trusses with single intersection web systems. Members shall be symmetrical about the central plane of the truss.

10.16.1.3 Trusses preferably shall have inclined end posts. Laterally unsupported hip joints shall be avoided.

10.16.1.4 Main trusses shall be spaced a sufficient distance apart, center to center, to be secure against overturning by the design lateral forces.

10.16.1.5 For the calculation of forces, effective depths shall be assumed as follows:

Riveted and bolted trusses, distance between centers of gravity of the chords.

Pin-connected trusses, distance between centers of chord pins

10.16.2 Truss Members

10.16.2.1 Chord and web truss members shall usually be made in the following shapes:

“H” sections, made with two side segments (composed of angles or plates) with solid web, perforated web, or web of stay plates and lacing.

Channel sections, made with two angle segments, with solid web, perforated web, or web of stay plates and lacing.

Single Box sections, made with side channels, beams, angles, and plates or side segments of plates only, connected top and bottom with perforated plates or stay plates and lacing.

Single Box sections, made with side channels, beams, angles and plates only, connected at top with solid cover plates and at the bottom with perforated plates or stay plates and lacing.

Double Box sections, made with side channels, beams, angles and plates or side segments of plates only, connected with a conventional solid web, together with top and bottom perforated cover plates or stay plates and lacing.

10.16.2.2 If the shape of the truss permits, compression chords shall be continuous.

10.16.2.3 In chords composed of angles in channel shaped members, the vertical legs of the angles preferably shall extend downward.

10.16.2.4 If web members are subject to reversal of stress, their end connections shall not be pinned. Counters preferably shall be rigid. Adjustable counters, if used, shall have open turnbuckles, and in the design of these members an allowance of 10,000 psi shall be made for initial stress. Only one set of diagonals in any panel shall be adjustable. Sleeve nuts and loop bars shall not be used.

10.16.3 Secondary Stresses

The design and details shall be such that secondary stresses will be as small as practicable. Secondary stresses due to truss distortion or floor beam deflection usually need not be considered in any member, the width of which, measured parallel to the plane of distortion, is less than one-tenth of its length. If the secondary stress exceeds 4,000 psi for tension members and 3,000 psi for compression members, the excess shall be treated as a primary stress. Stresses due to the flexural dead load moment of the member shall be considered as additional secondary stress.

10.16.4 Diaphragms

10.16.4.1 There shall be diaphragms in the trusses at the end connections of floor beams.

10.16.4.2 The gusset plates engaging the pedestal pin at the end of the truss shall be connected by a diaphragm. Similarly, the webs of the pedestal shall, if practicable, be connected by a diaphragm.

10.16.4.3 There shall be a diaphragm between gusset plates engaging main members if the end tie plate is 4 feet or more from the point of intersection of the members.

10.16.5 Camber

The length of the truss members shall be such that the camber will be equal to or greater than the deflection produced by the dead load.

10.16.6 Working Lines and Gravity Axes

10.16.6.1 Main members shall be proportioned so that their gravity axes will be as nearly as practicable in the center of the section.

10.16.6.2 In compression members of unsymmetrical section, such as chord sections formed of side segments and a cover plate, the gravity axis of the section shall coincide as nearly as practicable with the working line, except that eccentricity may be introduced to counteract dead load bending. In two-angle bottom chord or diagonal members, the working line may be taken as the gage line nearest the back of the angle or at the center of gravity for welded trusses.

10.16.7 Portal and Sway Bracing

10.16.7.1 Through truss spans shall have portal bracing, preferably, of the two-plane or box type, rigidly connected to the end post and the top chord flanges, and as deep as the clearance will allow. If a single plane portal is used, it shall be located, preferably, in the central transverse plane of the end posts, with diaphragms between the webs of the posts to provide for a distribution of the portal stresses. The portal bracing shall be designed to take the full end reaction of the top chord lateral system, and the end posts shall be designed to transfer this reaction to the truss bearings.

10.16.7.2 Through truss spans shall have sway bracing 5 feet or more deep at each intermediate panel point. Top lateral struts shall be at least as deep as the top chord.

10.16.7.3 Deck truss spans shall have sway bracing in the plane of the end posts and at all intermediate panel points. This bracing shall extend the full depth of the trusses below the floor system. The end sway bracing shall be proportioned to carry the entire upper lateral load to the supports through the end posts of the truss.

10.16.8 Perforated Cover Plates

When perforated cover plates are used, the following provisions shall govern their design.

10.16.8.1 The ratio of length, in direction of stress, to width of perforation, shall not exceed two.

10.16.8.2 The clear distance between perforations in the direction of stress shall not be less than the distance between points of support.

10.16.8.3 The clear distance between the end perforation and the end of the cover plate shall not be less than 1.25 times the distance between points of support.

10.16.8.4 The point of support shall be the inner line of fasteners or fillet welds connecting the perforated plate to the flanges. For plates butt welded to the flange edge of rolled segments, the point of support may be taken as the weld whenever the ratio of the outstanding flange width to flange thickness of the rolled segment is less than seven. Otherwise, the point of support shall be the root of the flange of the rolled segment.

10.16.8.5 The periphery of the perforation at all points shall have a minimum radius of 1½ inches.

10.16.8.6 For thickness of metal, see Article 10.35.2.

10.16.9 Stay Plates

10.16.9.1 Where the open sides of compression members are not connected by perforated plates, such members shall be provided with lacing bars and shall have stay plates as near each end as practicable. Stay plates shall be provided at intermediate points where the lacing is interrupted. In main members, the length of the

end stay plates between end fasteners shall be not less than 1¼ times the distance between points of support and the length of intermediate stay plates not less than ¾ of that distance. In lateral struts and other secondary members, the overall length of end and intermediate stay plates shall be not less than ¾ of the distance between points of support.

10.16.9.2 The point of support shall be the inner line of fasteners or fillet welds connecting the stay plates to the flanges. For stay plates butt welded to the flange edge of rolled segment, the point of support may be taken as the weld whenever the ratio of outstanding flange width to flange thickness or the rolled segment is less than seven. Otherwise, the point of support shall be the root of flange of rolled segment. When stay plates are butt welded to rolled segments of a member, the allowable stress in the member shall be determined in accordance with Article 10.3. Terminations of butt welds shall be ground smooth.

10.16.9.3 The separate segments of tension members composed of shapes may be connected by perforated plates or by stay plates or end stay plates and lacing. End stay plates shall have the same minimum length as specified for end stay plates on main compression members, and intermediate stay plates shall have a minimum length of ¾ of that specified for intermediate stay plates on main compression members. The clear distance between stay plates on tension members shall not exceed 3 feet.

10.16.9.4 The thickness of stay plates shall be not less than 1/50 of the distance between points of support for main members, and 1/60 of that distance for bracing members. Stay plates shall be connected by not less than three fasteners on each side, and in members having lacing bars the last fastener in the stay plates preferably shall also pass through the end of the adjacent bar.

10.16.10 Lacing Bars

When lacing bars are used, the following provisions shall govern their design.

10.16.10.1 Lacing bars of compression members shall be so spaced that the slenderness ratio of the portion of the flange included between the lacing bar connections will be not more than 40 or more than 2/3 of the slenderness ratio of the member.

10.16.10.2 The section of the lacing bars shall be determined by the formula for axial compression in which L is taken as the distance along the bar between its connections to the main segments for single lacing, and as 70 percent of that distance for double lacing.

10.16.10.3 If the distance across the member between fastener lines in the flanges is more than 15 inches and a bar with a single fastener in the connection is used, the lacing shall be double and fastened at the intersections.

10.16.10.4 The angle between the lacing bars and the axis of the member shall be approximately 45 degrees for double lacing and 60 degrees for single lacing.

10.16.10.5 Lacing bars may be shapes or flat bars. For main members, the minimum thickness of flat bars shall be $1/40$ of the distance along the bar between its connections for single lacing and $1/60$ for double lacing. For bracing members, the limits shall be $1/50$ for single lacing and $1/75$ for double lacing.

10.16.10.6 The diameter of fasteners in lacing bars shall not exceed one-third the width of the bar. There shall be at least two fasteners in each end of lacing bars connected to flanges more than 5 inches in width.

10.16.11 Gusset Plates

10.16.11.1 Gusset or connection plates preferably shall be used for connecting main members, except when the members are pin-connected. The fasteners connecting each member shall be symmetrical with the axis of the member, so far as practicable, and the full development of the elements of the member shall be given consideration. The gusset plates shall be designed to resist shear, axial force, and bending moments acting on the weakest or critical section.

10.16.11.2 Re-entrant cuts, except curves made for appearance, shall be avoided as far as practicable.

10.16.11.3 If the length of unsupported edge of a gusset plate exceeds the value of the expression $11,000/\sqrt{F_y}$ times its thickness, the edge shall be stiffened.

10.16.11.4 Listed below are the values of the expression $11,000/\sqrt{F_y}$ for the following grades of steel:

F_y (psi)	$11,000/\sqrt{F_y}$	
36,000	58	+
50,000	49	+
70,000	42	+
90,000	37	+
100,000	35	+

10.16.12 Half-Through Truss Spans

10.16.12.1 The vertical truss members and the floor beams and their connections in half-through truss spans shall be proportioned to resist a lateral force of not less than 300 pounds per linear foot applied at the top chord panel points of each truss.

10.16.12.2 The compression chord shall be designed as a compression member with elastic lateral supports at the panel points. The strength of the compression chord, so determined, shall exceed the maximum force from dead load, live load, and impact in any panel of the compression chord by not less than 50 percent.*

10.16.13 Fastener Pitch in Ends of Compression Members

In the ends of compression members, the pitch of fasteners connecting the component parts of the member shall not exceed four times the diameter of the fastener for a length equal to $1\frac{1}{2}$ times the maximum width of the member. Beyond this point, the pitch shall be increased gradually for a length equal to $1\frac{1}{2}$ times the maximum width of the member until the maximum pitch is reached.

10.16.14 Net Section of Riveted or High-Strength Bolted Tension Members

10.16.14.1 The net section of a riveted or high-strength bolted tension member is the sum of the net sections of its component parts. The net section of a part is the product of the thickness of the part multiplied by its least net width.

* For a discussion of columns with elastic lateral supports, refer to Timoshenko & Gere, "Theory of Elastic Stability," McGraw-Hill Book Co., Second Edition, P.70.

10.16.14.2 The net width for any chain of holes extending progressively across the part shall be obtained by deducting from the gross width the sum of the diameters of all the holes in the chain and adding, for each gage space in the chain, the quantity:

$$+ \frac{s^2}{4g} \quad (10-4)$$

where:

- + s = pitch of any two successive holes in the chain (in.)
- + g = gage of the same holes (in.)

The net section of the part is obtained from the chain that gives the least net width.

10.16.14.3 For angles, the gross width shall be the sum of the widths of the legs less the thickness. The gage for holes in opposite legs shall be the sum of gages from back of angle less the thickness.

+ **10.16.14.4** At a splice, the total force in the member being spliced is transferred by fasteners to the splice material.

+ **10.16.14.5** When determining the stress on any least net width of either splice material or member being spliced, the amount of the force previously transferred by fasteners adjacent to the section being investigated shall be considered in determining the stress on the net section.

10.16.14.6 The diameter of the hole shall be taken as $\frac{1}{8}$ inch greater than the nominal diameter of the rivet or high-strength bolt, unless larger holes are permitted in accordance with Article 10.24.

10.17 BENTS AND TOWERS

10.17.1 General

Bents preferably shall be composed of two supporting columns, and the bents usually shall be united in pairs to form towers. The design of members for bents and towers is governed by applicable articles.

10.17.2 Single Bents

Single bents shall have hinged ends or else shall be designed to resist bending.

10.17.3 Batter

Bents preferably shall have a sufficient spread at the base to prevent uplift under the design lateral loadings. In general, the width of a bent at its base shall be not less than one-third of its height.

10.17.4 Bracing

10.17.4.1 Towers shall be braced, both transversely and longitudinally, with stiff members having either welded, high-strength bolted or riveted connections. The sections of members of longitudinal bracing in each panel shall not be less than those of the members in corresponding panels of the transverse bracing.

10.17.4.2 The bracing of long columns shall be designed to fix the column about both axes at or near the same point.

10.17.4.3 Horizontal diagonal bracing shall be placed in all towers having more than two vertical panels, at alternate intermediate panel points.

10.17.5 Bottom Struts

The bottom struts of towers shall be strong enough to slide the movable shoes with the structure unloaded, the coefficient of friction being assumed at 0.25. Provision for expansion of the tower bracing shall be made in the column bearings.

10.18 SPLICES

10.18.1 General

10.18.1.1 Design Strength

Splices may be made by rivets, by high-strength bolts, or by the use of welding. In general, splices whether in tension, compression, bending, or shear, shall be designed in the cases of the service load design or the strength design methods for a capacity based on not less than 100 percent of the allowable design strength in the

+ member taking into account the bolt holes. Bolted and
 + riveted splices in flexural members shall satisfy the
 + requirements of Article 10.18.2. Bolted and riveted splices
 + in compression members shall satisfy the requirements of
 + Article 10.18.3. Bolted and riveted splices in tension
 + members shall satisfy the requirements of Article 10.18.4.
 + Bolted and riveted splices in tension members shall also
 + satisfy the requirements of Article 10.19.4. Welded splices
 + shall satisfy the requirements of Article 10.18.5. Where
 + a section changes at a splice, the small section is to be
 + used to satisfy the above splice requirements.

10.18.1.2 Fillers

10.18.1.2.1 For fillers 1/4 inch and thicker in bolted or
 riveted axially loaded connections, including girder flange
 splices, additional fasteners shall be required to distribute
 the total stress in the member uniformly over the combined
 section of the member and the filler. The filler shall either be
 + extended beyond the splice material and secured by addi-
 + tional fasteners, or as an alternate to extending the filler, an
 + equivalent number of fasteners may be included in the
 + connection. Fillers 1/4 inch and thicker need not be extended
 + and developed provided that the design shear strength of the
 + fasteners, specified in Article 10.56.1.3.2 in the case of the
 + strength design method and in the Tables 10.32.3A and
 + 10.32.3B in the case of the service load design method, is
 reduced by the following factor *R*:

$$R = [(1 + \gamma) / (1 + 2\gamma)] \quad (10-4a)$$

where $\gamma = A_f / A_p$

+ $A_f =$ sum of the area of the fillers on the top and
 + bottom of the connected plate (in.²)
 + $A_p =$ smaller of either the connected plate area or
 + the sum of the splice plate areas on the top and
 + bottom of the connected plate (in.²)

+ The design slip force, specified in Article 10.56.1.3.2
 + in the case of the strength design method and in Article
 10.32.3.2.1 in the case of the service load design method,
 for slip-critical connections shall not be adjusted for the
 effect of the fillers. Fillers 1/4 inch or more in thickness
 shall consist of not more than two plates, unless special
 permission is given by the Engineer.

10.18.1.2.2 For bolted web splices with thickness
 differences of 1/16 inch or less, no filler plates are
 required.

10.18.1.2.3 Fillers for welded splices shall conform to the
 requirements of the *AISI/AASHTO/AWS D1.5 Bridge
 Welding Code*.

10.18.1.3 Design Force for Flange Splice Plates

For a flange splice with inner and outer splice plates,
 the flange design force may be assumed to be divided
 equally to the inner and outer plates and their connections
 when the areas of the inner and outer plates do not differ
 by more than 10 percent. When the areas of the inner and
 outer plates differ by more than 10 percent, the design
 force in each splice plate and its connection shall be
 determined by multiplying the flange design force by the
 ratio of the area of the splice plate under consideration to
 the total area of the inner and outer splice plates. For this
 case, the shear strength of the connection shall be checked
 for the maximum calculated splice plate force acting on
 a single shear plane. The slip resistance of high-strength
 bolted connections for a flange splice with inner and
 outer splice plates shall always be checked for the flange
 design force divided equally to the two slip planes.

10.18.1.4 Truss Chords and Columns

Splices in truss chords and columns shall be located as
 near to the panel points as practicable and usually on the
 side where smaller stress occurs. The arrangement of
 plates, angles, or other splice elements shall be such as to
 make proper provision for the stresses, both axial and
 bending, in the component parts of the member spliced.

10.18.2 Flexural Member

10.18.2.1 General

10.18.2.1.1 Splices shall preferably be made at or near
 + points of dead load contraflexure in continuous spans and
 + at points of the section change. +

10.18.2.1.2 In both flange and web splices, there shall
 be not less than two rows of bolts on each side of the joint.

10.18.2.1.3 Oversize or slotted holes shall not be used
 in either the member or the splice plates at the bolted
 splices.

10.18.2.1.4 In both flange and web splices, high-
 strength bolted connections shall be proportioned to
 prevent slip during erection of the steel and during the
 casting or placing of the deck.

+ 10.18.2.1.5 Deleted

10.18.2.1.6 Flange and web splices in areas of stress reversal shall be checked for both positive and negative flexure.

10.18.2.1.7 Riveted and bolted flange angle splices shall include two angles, one on each side of the flexural member.

10.18.2.2 Flange Splices

+ 10.18.2.2.1 For checking the strength of flange splices, an effective area, A_e , shall be used for the flanges and for the individual splice plates as follows:

+ For flanges and their splice plates subject to tension:

$$+ A_e = w_n t + \beta A_g \leq A_g \quad (10-4b)$$

+ where:

- + W_n = least net width of the flange or splice plate computed as specified in Article 10.16.14 (in.)
- + t = flange or splice plate thickness (in.)
- + A_g = gross area of the flange or splice plate (in.²)
- + β = 0.0 for M 270 Grade 100/100W steels, or when holes exceed 1 1/4 inch in diameter
- + = 0.15 for all other steels and when holes are less than or equal to 1 1/4 inch in diameter

+ The diameter of the holes shall be taken as specified in Article 10.16.14.6.

+ For the flanges and their splice plates subject to compression:

$$+ A_e = A_g \quad (10-4c)$$

+ 10.18.2.2.2 In the case of the strength design method, the splice plates shall be proportioned for a design force, P_{cu} equal to a design stress, F_{cu} , times the smaller effective area, A_e , on either side of the splice. F_{cu} is defined as follows:

$$+ F_{cu} = \alpha F_{yf} \quad (10-4d)$$

where:

- α = 1.0 except that a lower value equal to (M_u/M_y) may be used for flanges in compression at sections where M_u is less than M_y

M_u = design bending strength of the section in positive or negative flexure at the point of splice, whichever causes the maximum compressive stress due to the factored loads at the mid-thickness of the flange under consideration (lb-in.)

M_y = moment capacity at first yield for the section at the point of splice used to compute M_u (lb-in.). For composite sections, M_y shall be calculated in accordance with Article 10.50(c). For hybrid sections, M_y shall be computed in accordance with Article 10.53.

F_{yf} = specified minimum yield strength of the flange (psi)

In calculating M_u and M_y , holes in the flange subject to tension shall be accounted for as specified in Article 10.12. For a flange splice with inner and outer splice plates, the flange design forces shall be proportioned to the inner and outer plates and their connections as specified in Article 10.18.1.3. The effective area, A_e , of each splice plate shall be sufficient to prevent yielding of the splice plate under its calculated portion of the design force. As a minimum, the connections for both the top and bottom flange splices shall be proportioned to develop the design force in the flange through shear in the bolts and bearing at the bolt holes, as specified in Article 10.56.1.3.2. Where filler plates are required, the requirements of Article 10.18.1.2.1 shall also be satisfied.

As a minimum, high-strength bolted connection for both top and bottom flange splices shall be proportioned to prevent slip at an overload design force, P_{fo} , defined as follows:

$$P_{fo} = |f_o/R| A_g \quad (10-4e)$$

where:

- f_o = maximum flexural stress due to Group I loading divided by 1.3 at the mid-thickness of the flange under consideration for the smaller section at the point of splice (psi)
- R = reduction factor for hybrid girders specified in Article 10.53.1.2. R shall be taken equal to 1.0 when f_o is less than or equal to the specified minimum yield strength of the web, F_{yw} . For homogeneous girders, R shall always be taken equal to 1.0

+ A_g = smaller gross flange area on either side of the
 + splice (in.²)

f_o and R shall be computed using the gross section of the member. The slip resistance of the connection shall be computed from Equation (10-172).

+ **10.18.2.2.3** In the case of the service load design
 + method, the splice plates shall be proportioned for a
 + design force, P_{cf} , equal to the allowable flexural stress for
 + the flange under consideration at the point of splice, F_b ,
 times the smaller effective area, A_e , on either side of the
 splice.

+ For a flange splice with inner and outer splice plates,
 the flange design forces shall be proportioned to the inner
 and outer plates and their connections as specified in
 Article 10.18.1.3. The effective area, A_e , of each splice
 plate shall be sufficient to ensure that the stress in the
 splice plate does not exceed the allowable flexural stress
 under its calculated portion of the design force. As a
 minimum, the connections for both the top and bottom
 flange splices shall be proportioned to develop the design
 force in the flange through shear in the bolts and bearing
 at the bolt holes, as specified in Table 10.3.23B. Where
 filler plates are required, the requirements of Article
 10.18.1.2.1 shall also be satisfied.

+ As a minimum, high-strength bolted connection for
 + both top and bottom flange splices shall be proportioned
 to prevent slip at a force equal to the flange design stress
 times the smaller value of the gross flange area on either
 side of the splice. The slip resistance of the connection
 shall be determined as specified in Article 10.32.3.2.1.

+ **10.18.2.2.4** (Deleted)

10.18.2.3 Web Splices

10.18.2.3.1 In general, web splice plates and their connections shall be proportioned for shear, a moment due to eccentricity of the shear at the point of splice, and a portion of the flexural moment that is assumed to be resisted by the web at the point of splice. Webs shall be spliced symmetrically by plates on each side. The web splice plates shall extend as near as practical for the full depth between flanges.

10.18.2.3.2 In the case of the strength design method, web splice plates and their connections shall be proportioned for a design shear, V_{wu} equal to the shear capacity of the smaller web at the point of splice, V_u .

10.18.2.3.3 In the case of the strength design method, web splice plates and their connections shall be proportioned for a design moment, M_{vu} due to the eccentricity of the design shear at the point of splice defined as follows:

$$M_{vu} = V_{wu}e \quad (10-4f)$$

where:

V_{wu} = design shear in the web at the point of splice defined in Article 10.18.2.3.2 (1b.)

e = distance from the centerline of the splice to the centroid of the connection on the side of the joint under consideration (in.)

10.18.2.3.4 In the case of the strength design method, web splice plates and their connections shall be proportioned for a design moment, M_{wu} , representing the portion of the flexural moment that is assumed to be resisted by the web. M_{wu} shall be applied at the mid-depth of the web. For sections where the neutral axis is not located at mid-depth of the web, a horizontal design force resultant in the web at the point of splice, H_{wu} , shall also be applied at the mid-depth of the web. M_{wu} and H_{wu} may be computed as follows:

For non-compact sections:

$$M_{wu} = \frac{t_w D^2}{12} (RF_{cr} + F_{yf}) \quad (10-4g)$$

$$H_{wu} = \frac{t_w D}{2} (F_{yf} - RF_{cr}) \quad (10-4h)$$

For compact sections:

$$M_{wu} = \frac{t_w F_{yw}}{4} (D^2 - 4y_c^2) \quad (10-4i)$$

$$H_{wu} = 2t_w y_o F_{yw} \quad (10-4j)$$

+ where:

+ F_{cr} = design flexural strength specified in Articles
 + 10.50.1.2 and 10.50.2.2 for composite sections,
 + or determined by $M_u/S_{xc}R_b$, where M_u is defined
 + as in Articles 10.48.2, 10.48.3, 10.48.4 for
 + noncomposite sections (psi)

+ F_{yf} = specified minimum yield strength of the flange
 + (psi)

+ F_{yw} = specified minimum yield strength of the web (psi)

+ y_o = distance from the mid-depth of the web to the
 + plastic neutral axis (in.)

+ D = clear unsupported distance between flange com-
 + ponents (in.)

+ t_w = web thickness (in.)

+ 10.18.2.3.5 In the case of the strength design method,
 + web splice plates and their connections shall be propor-
 + tioned for the most critical combination of V_{wu} , M_{vu} , M_{wu}
 + and H_{wu} . The connections shall be proportioned as eccentri-
 + cally loaded connections to resist the resultant design force
 + through shear in the bolts and bearing at the bolt holes, as
 + specified in Article 10.56.1.3.2. In addition, as a minimum,
 + high-strength bolted connections for web splices shall be
 + proportioned as eccentrically loaded connections to prevent
 + slip under the most critical combination of: 1) an overload
 + design shear, V_{wo} , 2) an overload design moment, M_{vo} , due
 + to the eccentricity of the overload design shear, 3) an
 + overload design moment, M_{wo} , applied at mid-depth of the
 + web representing the portion of the flexural moment that is
 + assumed to be resisted by the web, and 4) for sections where
 + the neutral axis is not located at mid-depth of the web, an
 + overload horizontal design force H_{wo} , applied at mid-depth
 + of the web, as follows:

$$+ \quad V_{wo} = V_o \quad (10-4k)$$

$$+ \quad M_{vo} = V_{wo}e \quad (10-4l)$$

where:

+ V_o = maximum shear in the web due to Group I
 + loading divided by 1.3 at the point of splice (lb.)

M_{wo} and H_{wo} may be determined as follows:

$$+ \quad M_{wo} = \frac{t_w D^2}{12} |f_o - f_{of}| \quad (10-4m)$$

$$+ \quad H_{wo} = \frac{t_w D}{2} (f_o + f_{of}) \quad (10-4n)$$

where:

f_o = maximum flexural stress due to Group I loading
 divided by 1.3 at the mid-thickness of the flange
 under consideration for smaller section at the
 point of splice (positive for tension; negative for
 compression) (psi)

f_{of} = flexural stress due to Group I loading divided by
 1.3 at the mid-thickness of the other flange at
 the point of splice concurrent with f_o in the
 flange under consideration (positive for tension
 ; negative for compression) (psi)

f_o and f_{of} shall be computed using the gross section of the
 member. The maximum resultant force on the eccentri-
 cally loaded connection shall not exceed the slip resis-
 tance computed from Equation (10-172) with N_b taken
 equal to 1.0.

10.18.2.3.6 In the case of the service load design
 method, web splice plates and their connections shall be
 proportioned for a design shear stress in the web at the
 point of splice, F_w equal to the allowable shear stress in
 the web at the point of splice, F_v .

10.18.2.3.7 In the case of the service load design
 method, web splice plates and their connections shall
 be proportioned for a design moment, M_v due to the
 eccentricity of the design shear at the point of splice
 defined as follows:

$$M_v = F_w D t_w e \quad (10-4o)$$

where:

F_w = design shear stress in the web at the point of
 splice defined in Article 10.18.2.3.6 (psi)

D = web depth (in.)

t_w = web thickness (in.)

10.18.2.3.8 In the case of the service design method,
 web splice plates and their connections shall be propor-
 tioned for a design moment, M_w , representing the portion of
 the flexural moment that is assumed to be resisted by the
 web. M_w shall be applied at the mid-depth of the web. For
 sections where the neutral axis is not located at mid-depth of
 the web, a horizontal design force resultant in the web at the
 point of splice, H_w , shall also be applied at the mid-depth of
 the web. M_w and H_w may be computed as follows:

$$M_w = \frac{t_w D^2}{12} (R F_{bc} + F_{br}) \quad (10-4p)$$

$$H_w = \frac{t_w D}{2} (F_{bt} - RF_{bc}) \quad (10-4q)$$

where:

- + F_{bc} = allowable compression flange stress specified in Table 10.32.1A (psi)
- + F_{bt} = allowable tension flange stress specified in Table 10.32.1A (psi)

+ 10.18.2.3.9 In the case of the service load design method, web splice plates and their connections shall be proportioned for the most critical combination of $F_w D t_w$, M_v , M_w , and H_w . The connections shall be proportioned as eccentrically loaded connections to resist the resultant design force through shear in the bolts and bearing at the bolt holes, as specified in Table 10.32.3B. In addition, as a minimum, high-strength bolted connections for web splices shall be proportioned as eccentrically loaded connections to prevent slip under the most critical combination of $F_w D t_w$, M_v , M_w , and H_w . M_v , M_w , and H_w shall be computed using the gross section of the member. The

maximum resultant force on the eccentrically loaded connection shall not exceed the slip resistance computed from Table 10.32.3.2.1 with N_b taken equal to 1.0.

10.18.3 Compression Members

Compression members such as columns and chords shall have ends in close contact at riveted and bolted splices. Splices of such members which will be fabricated and erected with close inspection and detailed with milled ends in full contact bearing at the splices may be held in place by means of splice plates and rivets or high-strength bolts proportioned for not less than 50 percent of the lower allowable design strength of sections spliced. The strength of compression members connected by high-strength bolts or rivets shall be determined using the gross section.

10.18.4 Tension Members

The tension strength of splice components shall be based on Article 10.12.3. For calculating the net section, the provisions of Articles 10.9 and 10.16.14 shall apply.

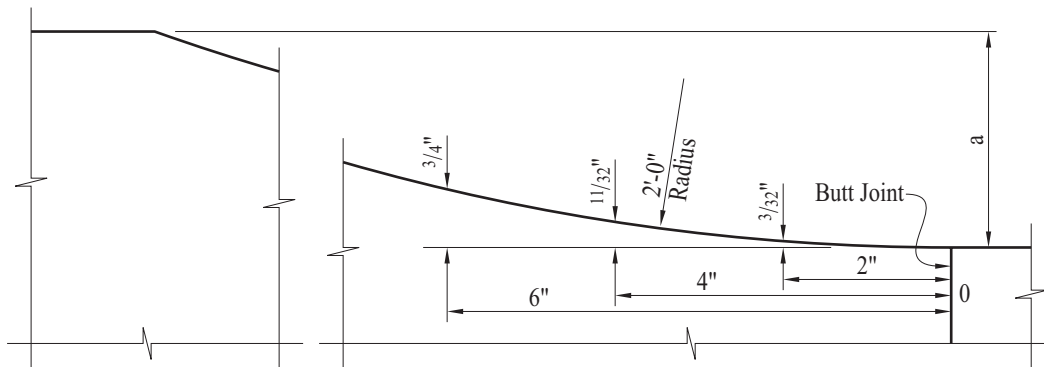

DETAIL OF WIDTH TRANSITION

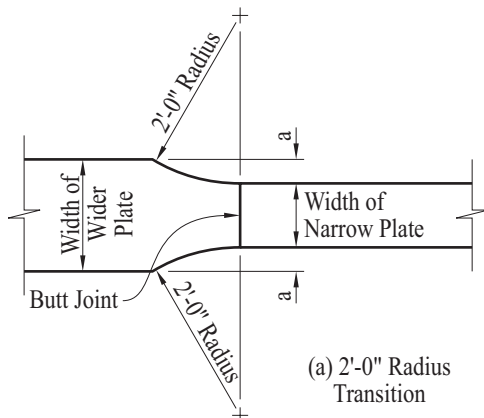

(a) 2'-0" Radius Transition

Note: (b) deleted

FIGURE 10.18.5A Splice Details

As a minimum, in the case of the strength design method, high-strength bolted connections for splices in tension members shall be proportioned to prevent slip at an overload design force, P_o , equal to the maximum tensile stress in the member due to Group I loading divided by 1.3 times the gross section of member. The slip resistance shall be computed from Equation (10-172). In the case of the service load design method, high-strength bolted connections shall be proportioned to prevent slip at a force equal to the allowable design strength specified in Article 10.18.1.1 times the gross area of the member. The slip resistance of the connection shall be determined as specified in Article 10.32.3.2.1.

10.18.5 Welding Splices

10.18.5.1 Tension and compression members may be spliced by means of full penetration butt welds, preferably without the use of splice plates.

10.18.5.2 Splices shall not be welded in field.

10.18.5.3 Material of different widths spliced by butt welds shall have transitions conforming to Figure 10.18.5A. At butt weld splices joining material of different thicknesses there shall be a uniform slope between the offset surfaces of not more than 1 in 2 $\frac{1}{2}$ with respect to the surface of either part.

10.19 CONNECTIONS

+ 10.19.1 General

+ **10.19.1.1** Except as otherwise provided herein, connections for main members shall be designed in the cases
+ of the service load design and the strength design meth-
+ ods for a capacity based on not less than 100 percent of
+ the allowable design strength in the member.

10.19.1.2 Connections shall be made symmetrical about the axis of the members insofar as practicable. Connections, except for lacing bars and handrails, shall contain not less than two fasteners or equivalent weld.

+ **10.19.1.3** Members, including bracing, preferably shall
+ be so connected that their gravity axes will intersect in a
point. Eccentric connections shall be avoided, if practi-
cable, but if unavoidable the members shall be so propor-
tioned that the combined forces will not exceed the
allowable design strength.

10.19.1.4 In the case of connections which transfer total member shear at the end of the member, the gross section shall be taken as the gross section of the connected elements.

10.19.2 End Connections of Floor Beams and Stringers

10.19.2.1 The end connection shall be designed for calculated member loads. The end connection angles of floor beams and stringers shall be not less than $\frac{3}{8}$ inch in finished thickness. Except in cases of special end floor beam details, each end connection for floor beams and stringers shall be made with two angles. The length of these angles shall be as great as the flanges will permit. Bracket or shelf angles which may be used to furnish support during erection shall not be considered in determining the number of fasteners required to transmit end shear.

10.19.2.2 End connection details shall be designed with special care to provide clearance for making the field connection.

10.19.2.3 End connections of stringers and floor beams preferably shall be bolted with high-strength bolts; however, they may be riveted or welded. In the case of welded end connections, they shall be designed for the vertical loads and the end bending moment resulting from the deflection of the members.

10.19.2.4 Where timber stringers frame into steel floor beams, shelf angles with stiffeners shall be provided to carry the total reaction. Shelf angles shall be not less than $\frac{7}{16}$ inch thick.

10.19.3 End Connections of Diaphragms and Cross Frames

10.19.3.1 The end connections for diaphragms or cross frames in straight rolled-beam and plate girder bridges shall be designed for the calculated member loads.

10.19.3.2 Vertical connection plates such as transverse stiffeners which connect diaphragms or cross frames to the beam or girder shall be rigidly connected to both top and bottom flanges.

+ **10.19.4 Block Shear Rupture Strength**

+ **10.19.4.1 General**

+ Block shear rupture is one of several possible failure
 + modes for splices, connections, gusset plates and tension
 + members. Block shear rupture failure is developed when
 + the net section of one segment ruptures and the gross
 + section of a perpendicular segment yields. The web
 + connections of coped beams, all tension connections
 + including connection plates, splice plates and gusset
 + plates, and tension members shall be investigated to
 + ensure that the adequate block shear rupture strength is
 + provided.

+ **10.19.4.2 Allowable Block Shear Rupture Stress**

+ In the Service Load Design Method, calculated ten-
 + sion stress based on the gross section shall not exceed the
 + allowable block shear rupture stress obtained from the
 + following equations:

+ for $A_m \geq 0.6 A_{vn}$

+
$$F_{bs} = (0.33 F_y A_{vg} + 0.55 F_u A_m) / A_g \quad (10-4r)$$

+ for $A_m < 0.6 A_{vn}$

+
$$F_{bs} = (0.33 F_u A_{vn} + 0.55 F_y A_{tg}) / A_g \quad (10-4s)$$

+ where:

- + A_g = gross area of whole connected material (in.²)
- + A_{vg} = gross area along the plane resisting shear (in.²)
- + A_{vn} = net area along the plane resisting shear (in.²)
- + A_{tg} = gross area along the plane resisting tension (in.²)
- + A_m = net area along the plane resisting tension (in.²)
- + F_y = specified minimum yield strength of the con-
 + nected materials (psi)
- + F_u = specified minimum tensile strength of the con-
 + nected materials (psi)
- + F_{bs} = allowable block shear rupture stress (psi)

10.19.4.3 Design Block Shear Rupture Strength

In the Strength Design Method, calculated tension
 force shall not exceed the design block shear rupture
 strength obtained from the following equations:

for $A_m \geq 0.58 A_{vn}$

$$T_{bs} = \phi_{bs} (0.58 F_y A_{vg} + F_u A_m) \quad (10-4t)$$

for $A_m < 0.58 A_{vn}$

$$T_{bs} = \phi_{bs} (0.58 F_u A_{vn} + F_y A_{tg}) \quad (10-4u)$$

where:

- T_{bs} = design block shear rupture strength (lb.)
- ϕ_{bs} = 0.8, reduction factor for block shear rupture
 strength

10.20 DIAPHRAGMS AND CROSS FRAMES

10.20.1 General

Rolled beam and plate girder spans shall be provided
 with cross frames or diaphragms at each support and with
 cross frames or diaphragms placed in all bays and spaced
 at intervals not to exceed 25 feet. Diaphragms for rolled
 beams shall be at least $1/3$ and preferably $1/2$ the beam
 depth and for plate girders shall be at least $1/2$ and
 preferably $3/4$ the girder depth. Cross frames shall be as
 deep as practicable. Cross frames shall preferably be of
 the cross type or vee type. End cross frames or dia-
 phragms shall be proportioned to adequately transmit all
 the lateral forces to the bearings. Intermediate cross
 frames shall be normal to the main beams and girders
 when the supports are skewed more than twenty degrees
 (20°). Cross frames on horizontally curved steel girder
 bridges shall be designed as main members with ad-
 equate provisions for transfer of lateral forces from the
 girder flanges. Cross frames and diaphragms shall be
 designed for horizontal wind loads as described in Article
 10.21.2, seismic loads and other applicable loads.

+ **10.20.2 Horizontal Force**

+ The maximum horizontal force, F_D (lb.), in the transverse diaphragms and cross frames is obtained from the following:

+
$$F_D = 1.14WS_d \quad (10-5)$$

+ where:

+ W = wind load along the exterior flange (lb/ft)

+ S_d = diaphragm spacing (ft)

+ **10.20.2.1 Deleted**

+ **10.20.2.2 Deleted**

+ **10.20.3 Deleted**

+ **10.21 LATERAL BRACING**

+ **10.21.1** The need for lateral bracing shall be investigated for wind loads, seismic loads and other applicable lateral loads. Flanges attached to concrete decks or other decks of comparable rigidity will not require lateral bracing.

+ **10.21.2** A horizontal wind force of 50 pounds per square foot shall be applied to the area of the superstructure exposed in elevation. Half this force shall be applied in the plane of each flange. The maximum induced stresses, f (psi), in the bottom flange of each girder in the system when top flanges are continuously supported can be computed from the following:

+
$$f = R f_{cb} \quad (10-6)$$

+
$$R = [0.2272L - 11]S_d^{-2/3} \begin{pmatrix} \text{when no bottom lateral} \\ \text{bracing is provided} \end{pmatrix} \quad (10-7)$$

+
$$R = [0.059L - 0.64]S_d^{-1/2} \begin{pmatrix} \text{when bottom lateral} \\ \text{bracing is provided} \end{pmatrix} \quad (10-8)$$

+
$$f_{cb} = \frac{72 M_{cb}}{t_f b_f^2} \quad (10-9)$$

+
$$M_{cb} = 0.08W S_d^2 \quad (10-10)$$

L = span length (ft.)

t_f = thickness of flange (in.)

b_f = width of flange (in.)

The stresses in flanges of each girder in the system when top flanges are not continuously supported shall be computed using the structural system in the plane of the flanges under consideration. The allowable stress shall be factored in accordance with Article 3.22.

10.21.3 When required, lateral bracing shall be placed in the exterior bays between diaphragms or cross frames. All required lateral bracing shall be placed in or near the plane of the flange being braced.

10.21.4 Where beams or girders comprise the main members of through spans, such members shall be stiffened against lateral deformation by means of gusset plates or knee braces with solid webs which shall be connected to the stiffeners on the main members and the floor beams. If the unsupported length of the edge of the gusset plate (or solid web) exceeds 60 times its thickness, the plate or web shall have a stiffening plate or angles connected along its unsupported edge.

10.21.5 Through truss spans, deck truss spans, and spandrel braced arches shall have top and bottom lateral bracing.

10.21.6 Bracing shall be composed of angles, other shapes, or welded sections. The smallest angle used in bracing shall be 3 by 2½ inches. There shall be not less than 2 fasteners or equivalent weld in each end connection of the angles.

10.21.7 If a double system of bracing is used, both systems may be considered effective simultaneously if the members meet the requirements both as tension and compression members. The members shall be connected at their intersections.

10.21.8 The lateral bracing of compression chords preferably shall be as deep as the chords and effectively connected to both flanges.

10.22 CLOSED SECTIONS AND POCKETS

10.22.1 Closed sections, and pockets or depressions that will retain water, shall be avoided where practicable.

Pockets shall be provided with effective drain holes or be filled with waterproofing material.

10.22.2 Details shall be so arranged that the destructive effects of bird life and the retention of dirt, leaves, and other foreign matter will be reduced to a minimum. Where angles are used, either singly or in pairs, they preferably shall be placed with the vertical legs extending downward. Structural tees preferably shall have the web extending downward.

10.23 WELDING

10.23.1 General

10.23.1.1 Steel base metal to be welded, weld metal, and welding design details shall conform to the requirements of the *ANSI/AASHTO/AWS D1.5 Bridge Welding Code* and the current Standard Specifications of the California Department of Transportation.

10.23.1.2 Welding symbols shall conform with the latest edition of the American Welding Society Publication AWS A2.4.

+ **10.23.1.3** Fabrication shall conform to the Standard Specifications of the California Department of Transportation. For fracture critical members see the *AASHTO "Guide Specifications for Fracture Critical Non-Redundant Steel Bridge Members."*

10.23.2 Effective Size of Fillet Welds

10.23.2.1 Maximum Size of Fillet Welds

The maximum size of a fillet weld that may be assumed in the design of a connection shall be such that the stresses in the adjacent base material do not exceed the values allowed in Article 10.32. The maximum size that may be used along edges of connected parts shall be:

- (1) Along edges of material less than $\frac{1}{4}$ inch thick, the maximum size may be equal to the thickness of the material.
- (2) Along edges of material $\frac{1}{4}$ inch or more in thickness, the maximum size shall be $\frac{1}{16}$ inch less than the thickness of the material, unless the weld is especially designated on the drawings to be built out to obtain full throat thickness.

10.23.2.2 Minimum Size of Fillet Welds

The minimum fillet weld size shall be as shown in the following table**.

Base Metal Thickness of Thicker Part Jointed (T)		Minimum Size of Fillet Weld*		
in.	mm	in.	mm	
$T \leq \frac{3}{4}$	T 19.0	$\frac{1}{4}$	6	} Single-pass Welds must be used
$T > \frac{3}{4}$	T > 19.0	$\frac{5}{16}$	8	

* Except that the weld size need not exceed the thickness of the thinner part jointed. For this exception, particular care should be taken to provide sufficient preheat to ensure weld soundness.

** Smaller fillet welds may be approved by the Engineer based upon applied stress and the use of appropriate preheat.

10.23.3 Minimum Effective Length of Fillet Welds

The minimum effective length of a fillet weld shall be four times its size and in no case less than $1\frac{1}{2}$ inches.

10.23.4 Fillet Weld End Returns

Fillet welds which support a tensile force that is not parallel to the axis of the weld, or which are proportioned to withstand repeated stress, shall not terminate at corners of parts or members but shall be returned continuously, full size, around the corner for a length equal to twice the weld size where such return can be made in the same plane. End returns shall be indicated on design and detail drawings.

10.23.5 Seal Welds

Seal welding shall preferably be accomplished by a continuous weld combining the functions of sealing and strength, changing section only as the required strength or the requirements of minimum size fillet weld, based on material thickness, may necessitate.

+ **10.24 FASTENERS**

10.24.1 General

+ **10.24.1.1** In proportioning fasteners, for shear and tension the cross-sectional area based upon the nominal diameter shall be used. Galvanization of AASHTOM253 (ASTM A490) and A354 Grade BD high strength bolts is not permitted due to hydrogen embrittlement problems. These fasteners must be carefully evaluated before being utilized. Requirements for bolts in these specifications shall be used for threaded rods, threaded studs and anchor rods, where applicable.

+ **10.24.1.2** High-strength bolts may be substituted for Grade 1 rivets (ASTM A 502) or ASTM A307 bolts. When AASHTO M 164 (ASTM A325) high-strength bolts are substituted for ASTM A307 bolts they shall be tightened to the full effort of a man using an ordinary spud wrench.

+ **10.24.1.3** All bolts, except high-strength bolts tensioned to the requirements of the Standard Specifications of the California Department of Transportation, shall have single self-locking nut, double nuts, or a nut with a thread locking system (anaerobic adhesive) to prevent nut loosening. The thread locking system is the preferred method for bolt diameters of one inch or less. The thread locking system shall not be used on bolt diameters greater than one inch. When using the double nut method a torque value for the jam nut, relative to the main nut, shall be shown on the plans to assure that a reasonable effort will be made to lock the two nuts together.

+ **10.24.1.4** Joints required to resist shear between their connected parts are designated as either slip-critical or bearing-type connections. Slip-critical joints are required for joints subject to stress reversal, heavy impact loads, severe vibration or where stress and strain due to joint slippage would be detrimental to the serviceability of the structure. They include:

- (1) Joints subject to fatigue loading.
- (2) Joints with bolts installed in oversized holes.
- (3) Except where the Engineer intends otherwise and so indicates in the contract documents, joints with bolts installed in slotted holes where the force on the joint is in a direction other than normal (between approximately 80 and 100 degrees) to the axis of the slot.

- (4) Joints subject to significant load reversal.
- (5) Joints in which welds and bolts share in transmitting load at a common faying surface.
- (6) Joints in which, in the judgment of the Engineer, any slip would be critical to the performance of the joint or the structure and so designated on the contract plans and specifications.

+ **10.24.1.5** High-strength bolted connections subject to tension, or combined shear and tension shall be designed as slip-critical connections. +

10.24.1.6 Bolted bearing-type connections using high-strength bolts shall be limited to members in compression and secondary members.

10.24.1.7 The effective bearing area of a fastener shall be its diameter multiplied by the thickness of the metal on which it bears. In metal less than $\frac{3}{8}$ inch thick, countersunk fasteners shall not be assumed to carry stress. In metal $\frac{3}{8}$ inch thick and over, one-half the depth of countersink shall be omitted in calculating the bearing area.

10.24.1.8 In determining whether the bolt threads are excluded from the shear planes of the contact surfaces, thread length of bolts shall be calculated as two thread pitches greater than the specified thread length as an allowance for thread run out.

10.24.1.9 In bearing-type connections, pull-out shear in a plate should be investigated between the end of the plate and the end row of fasteners. (See Table 10.32.3B, footnote h or Article 10.56.1.3.).

TABLE 10.24.2 Nominal Hole Dimension

Bolt Diameter (in.)	Hole Dimension (in.)			
	Standard (Diameter)	Oversize (Diameter)	Short Slot (Width × Length)	Long Slot (Width × Length)
$\frac{5}{8}$	$\frac{11}{16}$	$\frac{13}{16}$	$\frac{11}{16} \times \frac{7}{8}$	$\frac{11}{16} \times 1\frac{9}{16}$
$\frac{3}{4}$	$\frac{13}{16}$	$\frac{15}{16}$	$\frac{13}{16} \times 1$	$\frac{13}{16} \times 1\frac{7}{8}$
$\frac{7}{8}$	$\frac{15}{16}$	$1\frac{1}{16}$	$\frac{15}{16} \times 1\frac{1}{8}$	$\frac{15}{16} \times 2\frac{3}{16}$
1	$1\frac{1}{16}$	$1\frac{1}{4}$	$1\frac{1}{16} \times 1\frac{5}{16}$	$1\frac{1}{16} \times 2\frac{1}{2}$
$1\frac{1}{8}$	$d + \frac{1}{16}$	$d + \frac{5}{16}$	$(d + \frac{1}{16}) \times (d + \frac{3}{8})$	$(d + \frac{1}{16}) \times (2.5 \times d)$

10.24.2 Hole Types

Hole types for high-strength bolted connections are standard holes, oversize holes, short slotted holes and long slotted holes. The nominal dimensions for each type hole shall not be greater than those shown in Table 10.24.2.

10.24.2.1 In the absence of approval by the Engineer for use of other hole types, standard holes shall be used in high-strength bolted connections.

10.24.2.2 When approved by the Engineer, oversize, short slotted hole or long slotted holes may be used subject to the following joint detail requirements.

10.24.2.2.1 Oversize holes may be used in all plies of connections which satisfy the requirements of Article 10.32.3.2.1 or Article 10.57.3, as applicable. Oversize holes shall not be used in bearing-type connections.

10.24.2.2.2 Short slotted holes may be used in any or all plies of high-strength bolted connections designed on the basis of Table 10.32.3B or Table 10.56A, as applicable, provided the load is applied approximately normal (between 80 and 100 degrees) to the axis of the slot. Short slotted holes may be used without regard for the direction of applied load in any or all plies of connections which satisfy the requirements of Article 10.32.3.2.1 or Article 10.57.3.1, as applicable.

10.24.2.2.3 Long slotted holes may be used in one of the connected parts at any individual faying surface in high-strength bolted connections designed on the basis of Table 10.32.3B or Table 10.56A, as applicable, provided the load is applied approximately normal (between 80

and 100 degrees) to the axis of the slot. Long slotted holes may be used in one of the connected parts at any individual faying surface without regard for the direction of applied load on connections which satisfy the requirements of Article 10.32.3.2.1 or Article 10.57.3.1, as applicable.

10.24.3 Washer Requirements

Design details shall provide for washers in high-strength bolted connections as follows:

10.24.3.1 Where the outer face of the bolted parts has slope greater than 1:20 with respect to a plane normal to the bolt axis, a hardened beveled washer shall be used to compensate for the lack of parallelism. Beveled washers other than the standard 1:6 slope shall be detailed in the plans.

10.24.3.2 Hardened washers are not required for connections using AASHTO M164 (ASTM A325) and AASHTO M253 (ASTM A490) bolts except as required in Articles 10.24.3.3 through 10.24.3.7.

10.24.3.3 Hardened washers shall be used under the element turned in tightening and to cover oversize or short slotted holes in the outer ply.

10.24.3.4 Irrespective of the tightening method, hardened washers shall be used under both the head and the nut when AASHTO M253 (ASTM A490) bolts are to be installed in material having a specified yield strength less than 40,000 psi.



10.24.3.5 Where AASHTO M 164 (ASTM A 325) bolts of any diameter or AASHTO M 253 (ASTM A 490) bolts equal to or less than 1 inch in diameter are to be installed in an oversize or short slotted hole in an outer ply, a hardened washer conforming to ASTM F 436 shall be used.

10.24.3.6 When AASHTO M 253 (ASTM A 490) bolts over 1 inch in diameter are to be installed in an oversize or short slotted hole in an outer ply, hardened washers conforming to ASTM F 436 except with $\frac{5}{16}$ inch minimum thickness shall be used under both the head and the nut in lieu of standard thickness hardened washers. Multiple hardened washers with combined thickness equal to or greater than $\frac{5}{16}$ inch do not satisfy this requirement.

10.24.3.7 Where AASHTO M 164 (ASTM A 325) bolts of any diameter or AASHTO M 253 (ASTM A 490) bolts equal to or less than 1 inch in diameter are to be installed in a long slotted hole in an outer ply, a plate washer or continuous bar of at least $\frac{5}{16}$ inch thickness with standard holes shall be provided. These washers or bars shall have a size sufficient to completely cover the slot after installation and shall be of structural grade material but need not be hardened except as follows. When AASHTO M 253 (ASTM A 490) bolts over 1 inch in diameter are to be used in long slotted holes in external plies, a single hardened washer conforming to ASTM F 436 but with $\frac{5}{16}$ inch minimum thickness shall be used in lieu of washers or bars of structural grade material. Multiple hardened washers with combined thickness equal to or greater than $\frac{5}{16}$ inch do not satisfy this requirement.

10.24.4 Size of Fasteners (Rivets or High-Strength Bolts)

10.24.4.1 Fasteners shall be of the size shown on the drawings, but generally shall be $\frac{3}{4}$ inch or $\frac{7}{8}$ inch in diameter. Fasteners $\frac{5}{8}$ inch in diameter shall not be used in members carrying design loads except in $2\frac{1}{2}$ -inch legs of angles and in flanges of sections.

10.24.4.2 The diameter of fasteners in angles carrying design loads shall not exceed one-fourth the width of the leg in which they are placed.

10.24.4.3 In angles whose size is not determined by design loads, $\frac{5}{8}$ -inch fasteners may be used in 2-inch legs, $\frac{3}{4}$ -inch fasteners in $2\frac{1}{2}$ -inch legs, $\frac{7}{8}$ -inch fasteners in 3-inch legs, and 1-inch fasteners in $3\frac{1}{2}$ -inch legs.

10.24.4.4 Structural shapes which do not admit the use of $\frac{5}{8}$ -inch diameter fasteners shall not be used except in handrails.

10.24.5 Spacing of Fasteners

10.24.5.1 Pitch and Gage of Fasteners

The pitch of fasteners is the distance along the line of principal stress, between centers of adjacent fasteners, measured along one or more fastener lines. The gage of fasteners is the distance between adjacent lines of fasteners or the distance from the back of angle or other shape to the first line of fasteners.

10.24.5.2 Minimum Spacing of Fasteners

The minimum distance between centers of fasteners in standard holes shall be three times the diameter of the fastener but, preferably, shall not be less than the following:

Fastener Diameter (in.)	Minimum Spacing (in.)
1	$3\frac{1}{2}$
$\frac{7}{8}$	3
$\frac{3}{4}$	$2\frac{1}{2}$
$\frac{5}{8}$	$2\frac{1}{4}$

10.24.5.3 Minimum Clear Distance between Holes

When oversize or slotted holes are used, the minimum clear distance between the edges of adjacent holes in the direction of the force and transverse to the direction of the force shall not be less than twice the diameter of the bolt.

10.24.5.4 Maximum Spacing of Fasteners

The maximum spacing of fasteners shall be in accordance with the provisions of Articles 10.24.6, as applicable.

10.24.6 Maximum Spacing of Sealing and Stitch Fasteners

10.24.6.1 Sealing Fasteners

For sealing against the penetration of moisture in joints, the fastener spacing along a single line of fasteners adjacent to a free edge of an outside plate or shape shall not exceed 4 inches + 4*t* or 7 inches. If there is a second line of fasteners uniformly staggered with those in the line adjacent to the free edge, at a gage “*g*” less than $1\frac{1}{2}$ inches + 4*t* therefrom, the staggered pitch in two such lines, considered together, shall not exceed 4 inches + 4*t* – 3*g*/4 or 7 inches, but need not be less than one-half the requirement for a single line, where *t* is the thickness of the thinner outside plate or shape (in.), and *g* is the gage between fasteners (in.).

10.24.6.2 Stitch Fasteners

In built-up members where two or more plates or shapes are in contact, stitch fasteners shall be used to ensure that the parts act as a unit and, in compression members, to prevent buckling. In compression members the pitch of stitch fasteners on any single line in the direction of stress shall not exceed 12*t*, except that, if the fasteners on adjacent lines are staggered and the gage, *g*, between the line under consideration and the farther adjacent line (if there are more than two lines) is less than 24*t*, the staggered pitch in the two lines, considered together, shall not exceed 12*t* or 15*t* – 3*g*/8. The gage between adjacent lines of fasteners shall not exceed 24*t*. In tension members the pitch shall not exceed twice that specified for compression members and the gage shall not exceed that specified for compression members.

The maximum pitch of fasteners in built-up members shall be governed by the requirements for sealing or stitch fasteners, which is minimum.

For pitch of fasteners in the ends of compression members, see Article 10.16.13.

10.24.7 Edge Distance of Fasteners

10.24.7.1 General

The distance from the center of any fastener in a standard hole to an edge of a connected part shall not be less than the applicable value specified in Table 10.24.7.1.A.

The maximum distance from the center of any fastener to any edge shall be eight times the thickness of the thinnest outside plate, but shall not exceed 5 inches.

10.24.7.2 When there is only a single transverse fastener in the direction of the line of force in a standard or short slotted hole, the distance from the center of the hole to the edge of the connected part shall not be less than $1\frac{1}{2}$ times the diameter of the fastener, unless accounted for by the bearing provisions of Table 10.32.3B or Article 10.56.1.3.2.

10.24.7.3 When oversize or slotted holes are used, the distance between edges of holes and edges of members shall not be less than the diameter of the bolt.

TABLE 10.24.7.1A Minimum Edge Distance from Center of Standard Hole to Edge of Connected Part

Fasteners Diameter (in.)	At Sheared or Thermally Cut Edges (in.)	At Rolled or Planed Edges (in.)	At Flange Edges of Beams and Channels (in.)
1	$1\frac{3}{4}$	$1\frac{1}{2}$	$1\frac{1}{4}$
$\frac{7}{8}$	$1\frac{1}{2}$	$1\frac{1}{4}$	$1\frac{1}{8}$
$\frac{3}{4}$	$1\frac{1}{4}$	$1\frac{1}{8}$	1
$\frac{5}{8}$	$1\frac{1}{8}$	1	$\frac{7}{8}$

10.24.8 Long Rivets

Rivets subjected to design forces and having a grip in excess of $4\frac{1}{2}$ diameters shall be increased in number at least 1 percent for each additional $\frac{1}{16}$ inch of grip. If the grip exceeds six times the diameter of the rivet, specially designed rivets shall be used.

10.25 LINKS AND HANGERS

10.25.1 Net Section

In pin-connected tension members other than eyebars, the net section across the pin hole shall be not less than 140 percent, and the net section back of the pin hole not less than 100 percent of the required net section of the body of the member. The ratio of the net width (through the pin hole transverse to the axis of the member) to the thickness of the segment shall not be more than 8. Flanges not bearing on the pin shall not be considered in the net section across the pin.

- + Pin plates are not recommended in new construction.
- + The thickness required shall be full length. Hanger plates shall be designed to provide free movement of the parts.

10.25.2 Location of Pins

Pins shall be so located with respect to the gravity axis of the members as to reduce to a minimum the stresses due to bending.

10.25.3 Size of Pins

- + Pins shall be proportioned for the maximum shears and bending moments produced by the members connected. If there are eyebars among the parts connected, the diameter of the pin shall be not less than

$$+ \left[\frac{3}{4} + \frac{F_y}{400,000} \right] b_{eb} \quad (10-11)$$

where:

- + F_y = specified minimum yield strength of steel (psi)
- + b_{eb} = width of the body of the eyebar (in.)

10.25.4 Pin Plates

- + When necessary for the required section or bearing area, the section at the pin holes shall be increased on each segment by plates so arranged as to reduce to a minimum the eccentricity of the segment. One plate on each side shall be as wide as the outstanding flanges will allow. At least one full-width plate on each segment shall extend to the far edge of the stay plate and the others not less than 6 inches beyond the near edge. These plates shall be connected by enough rivets, bolts, or fillet welds to transmit the bearing pressure, and so arranged as to distribute it uniformly over the full section.

10.25.5 Pins and Pin Nuts

- + **10.25.5.1** Pins shall be of sufficient length to secure a full bearing of all parts connected upon the turned body of the pin. They shall be secured in position by hexagonal recessed nuts or by hexagonal solid nuts with washers. If the pins are bored, through rods with cap washers may be used.
- + Pin nuts shall be malleable castings or steel. They shall be secured by cotter pins or other suitable locking devices which will not affect the removal of the nut.

10.25.5.2 Members shall be restrained against lateral movement on the pins and against lateral distortion due to the skew of the bridge.

10.26 UPSET ENDS

Bars and rods with screw ends, where specified, shall be upset to provide a section at the root of the thread, which will exceed the net section of the body of the member by at least 15 percent.

10.27 EYEBARS

10.27.1 Thickness and Net Section

Eyebars shall be of a uniform thickness without reinforcement at the pin holes. The thickness of eyebars shall be not less than $1/8$ of the width, nor less than $1/2$ inch, and not greater than 2 inches. The section of the head through the center of the pin hole shall exceed the required section of the body of the bar by at least 35 percent. The net section back of the pin hole shall not be less than 75 percent of the required net section of the body of the member. The radius of transition between the head and body of the eyebar shall be equal to or greater than the width of the head through the centerline of the pin hole.

10.27.2 Packing of Eyebars

10.27.2.1 The eyebars of a set shall be symmetrical about the central plane of the truss and as nearly parallel as practicable. Bars shall be as close together as practicable and held against lateral movement, but they shall be so arranged that adjacent bars in the same panel will be separated by at least $1/2$ inch.

10.27.2.2 Intersecting diagonal bars not far enough apart to clear each other at all times shall be clamped together at the intersection.

10.27.2.3 Steel filling rings shall be provided, if needed, to prevent lateral movement of eyebars or other members connected on the pin.

10.28 FORKED ENDS

Forked ends will be permitted only where unavoidable. There shall be enough pin plates on forked ends to

make the section of each jaw equal to that of the member. The pin plates shall be long enough to develop the pin plate beyond the near edge of the stay plate, but not less than the length required by Article 10.25.4.

10.29 FIXED AND EXPANSION BEARINGS

10.29.1 General

+ **10.29.1.1** Fixed ends shall be firmly anchored. Bearings for spans less than 50 feet need have no provision for rotation. Spans of 50 feet or greater shall be provided with a type of bearing to accommodate rotation.

+ **10.29.1.2** Expansion ends shall be provided with a type of bearing to accommodate rotation and expansion.

+ **10.29.1.3** Deleted

+ **10.29.2** Deleted

+ **10.29.3** Deleted

+ **10.29.4 Sole Plates and Masonry Plates**

10.29.4.1 Sole plates and masonry plates shall have a minimum thickness of $\frac{3}{4}$ inch.

10.29.4.2 For spans on inclined grades greater than 1 percent without hinged bearings, the sole plates shall be beveled so that the bottom of the sole plate is level, unless the bottom of the sole plate is radially curved.

10.29.5 Masonry Bearings

Beams, girders, or trusses on masonry shall be so supported that the bottom chords or flanges will be above the bridge seat, preferably not less than 6 inches.

+ **10.29.6 Anchor Rods**

+ **10.29.6.1** Trusses, girders, and rolled beam spans preferably shall be securely anchored to the substructure. Anchor rods shall be headed, hooked, or threaded with a nut to secure a satisfactory grip upon the material used to embed them in the holes. All anchor rods shall conform to specifications shown in Table 10.2C. High strength steels (quenched and tempered) are not recommended for use in hooked anchor rods since bending with heat may

affect their strength. The embedded end of a threaded rod with a nut shall have a positive locking device or system to prevent rod rotation when a nut is installed on other end. +

10.29.6.2 The following are the minimum requirements for each bearing:

For rolled beam spans the outer beams shall be anchored at each end with 2 rods, 1 inch in diameter, set 10 inches in the masonry. +

For trusses and girders:

Spans 50 feet in length or less; 2 rods, 1 inch in diameter set 10 inches in the masonry. +

Spans 51 to 100 feet; 2 rods, $1\frac{1}{4}$ inches in diameter, set 12 inches in the masonry. +

Spans 101 to 150 feet; 2 rods, $1\frac{1}{2}$ inches in diameter, set 15 inches in the masonry. +

Spans greater than 150 feet; 4 rods, $1\frac{1}{2}$ inches in diameter, set 15 inches in the masonry. +

10.29.6.3 Anchor rods shall be designed to resist uplift as specified in Article 3.17 and seismic forces specified in Article 3.21. Other restraining devices may be used in conjunction with anchor rods. +

10.29.7 Pedestals and Shoes

10.29.7.1 Pedestals and shoes preferably shall be made of cast steel or structural steel. The difference in width between the top and bottom bearing surfaces shall not exceed twice the distance between them. For hinged bearings, this distance shall be measured from the center of the pin. In built-up pedestals and shoes, the web plates and angles connecting them to the base plate shall be not less than $\frac{5}{8}$ inch thick. If the size of the pedestal permits, the webs shall be rigidly connected transversely. The minimum thickness of the metal in cast steel pedestals shall be 1 inch. Pedestals and shoes shall be so designed that the load will be distributed uniformly over the entire bearing.

10.29.7.2 Webs and pin holes in the webs shall be arranged to keep any eccentricity to a minimum. The net



section through the hole shall provide 140 percent of the net section required for the design load transmitted through the pedestal or shoe. Pins shall be of sufficient length to secure a full bearing. Pins shall be secured in position by appropriate nuts with washers. All portions of pedestals and shoes shall be held against lateral movement of the pins.

10.30 FLOOR SYSTEM

10.30.1 Stringers

Stringers preferably shall be framed into floor beams. Stringers supported on the top flanges of floor beams preferably shall be continuous.

10.30.2 Floor Beams

Floor beams preferably shall be at right angles to the trusses or main girders and shall be rigidly connected thereto. Floor beam connections preferably shall be located so the lateral bracing system will engage both the floor beam and the main supporting member. In pin-connected trusses, if the floor beams are located below the bottom chord pins, the vertical posts shall be extended sufficiently below the pins to make a rigid connection to the floor beam.

10.30.3 Cross Frames

In bridges with wooden floors and steel stringers, intermediate cross frames (or diaphragms) shall be placed between stringers more than 20 feet long.

10.30.4 Expansion Joints

10.30.4.1 To provide for expansion and contraction movement, floor expansion joints shall be provided at all expansion ends of spans and at other points where they may be necessary.

10.30.4.2 Apron plates, when used, shall be designed to bridge the joint and to prevent, so far as practicable, the accumulation of roadway debris upon the bridge seats. Preferably, they shall be connected rigidly to the end floor beam.

10.30.5 End Floor Beams

There shall be end floor beams in all square-ended trusses and girder spans and preferably in skew spans. End floor beams for truss spans preferably shall be designed to permit the use of jacks for lifting the superstructure. For this case the allowable stresses may be increased 50 percent.

10.30.6 End Panel of Skewed Bridges

In skew bridges without end floor beams, the end panel stringers shall be secured in correct position by end struts connected to the stringers and to the main truss or girder. The end panel lateral bracing shall be attached to the main trusses or girders and also to the end struts. Adequate provisions shall be made for the expansion movement of stringers.

10.30.7 Sidewalk Brackets

Sidewalk brackets shall be connected in such a way that the bending stresses will be transferred directly to the floor beams.

10.30.8 Stay-in-Place Deck Forms

10.30.8.1 Concrete Deck Panels

When precast prestressed deck panels are used as permanent forms spanning between beams, stringers, or girders, the requirements of Article 9.12, Deck Panels, and Article 9.23, Deck Panels, shall be met.

10.30.8.2 Metal Stay-in-Place Forms

When metal stay-in-place forms are used as permanent forms spanning between beams, stringers, or girders, the forms shall be designed a minimum of, to support the weight of the concrete (including that in the corrugations, if applicable), a construction load of 50 psf, and the weight of the form. The forms shall be designed to be elastic under construction loads. The elastic deformation caused by the dead load of the forms, plastic concrete and reinforcement, shall not exceed a deflection greater than $L/80$ or one half inch, for form work spans (L) of 10 feet or less, or a deflection of $L/240$ or three-quarter inch, for form work for spans L over 10 feet. Dead load due to metal stay-in-place forms shall be taken into account in design of girders.



Part C Service Load Design Method

Allowable Stress Design

10.31 SCOPE

Allowable stress design is a method for proportioning structural members using design loads and forces, allowable stresses, and design limitations for the appropriate material under service conditions. See Part D – Strength Design Method – Load Factor Design for a preferred design procedure.

10.32 ALLOWABLE STRESSES

10.32.1 Steel

Allowable stresses for steel shall be as specified in Table 10.32.1A.

10.32.2 Weld Metal

Unless otherwise specified, the ultimate strength of weld metal shall be equal to or greater than specified minimum value of the base metal. Allowable stresses on the effective areas of weld metal shall be as follows:

Butt Welds

The same as the base metal joined, except in the case of joining metals of different yields when the lower yield material shall govern.

Fillet Welds

$$F_v = 0.27 F_u \quad (10-12)$$

where:

F_v = allowable basic shear stress (psi)
 F_u = tensile strength of the electrode classification (psi).

When detailing fillet welds for quenched and tempered steels the designer may use electrode classifications with strengths less than the base metal provided that this requirement is clearly specified on the plans.

10.32.3 Fasteners

Allowable stresses for fasteners shall be as listed in Tables 10.32.3A and 10.32.3B, and the allowable force on a slip-critical connection shall be as provided by Article 10.32.3.2.1.

10.32.3.1 General

10.32.3.1.1 In proportioning fasteners for shear or tension, the cross sectional area based upon the nominal diameter shall be used except as otherwise noted.

10.32.3.1.2 The effective bearing area of a fastener shall be its diameter multiplied by the thickness of the metal on which it bears. In metal less than $\frac{3}{8}$ inch thick, countersunk fasteners shall not be assumed to carry load. In metal $\frac{3}{8}$ inch thick and over, one-half of the depth of countersink shall be omitted in calculating the bearing area.

10.32.3.1.3 In determining whether the bolt threads are excluded from the shear planes of the contact surfaces, thread length of bolts shall be calculated as at least two thread pitches greater than the specified thread length as an allowance for thread run out.

10.32.3.1.4 In bearing-type connections, pull-out shear in a plate should be investigated between the end of the plate and the end row of fasteners. (See Table 10.32.3B, footnote g.)

10.32.3.1.5 Deleted

10.32.3.1.6 Joints, utilizing high-strength bolts, required to resist shear between their connected parts are designated as either slip-critical (see Article 10.24.1.4) or bearing-type connections. Shear connections subjected to stress reversal, or where slippage would be undesirable, shall be slip-critical connections. Potential slip of joints should be investigated at intermediate load stages especially those joints located in composite regions.

10.32.3.1.7 The percentage of stress increase shown in Article 3.22, Combination of Loads, shall apply to allowable stresses in bolted slip-critical connections using high-strength bolts, except that in no case shall the percentage of allowable stress exceed 133 percent, and the requirements of Article 10.32.3.3 shall not be exceeded.



10.32.3.1.8 Bolted bearing-type connections shall be limited to members in compression and secondary members.

10.32.3.2 The allowable stress in shear, bearing and tension for AASHTO M164 (ASTM A325) and AASHTO M253 (ASTM A490) bolts shall be as listed in Table 10.32.3B.

- + High strength bolts installed according to the Standard
- + Specifications of the California Department of Transportation, Section 55, will be fully tensioned and the contact
- + surface condition of the assembly will be Class B.

TABLE 10.32.1A Allowable Stresses—Structural Steel (psi)

		M 270 Grade 36	M 270 Grade 50	M 270 Grade 50W	A 709 Grade HPS 70W	M 270 Grades 100/100W	A 709 Grades 100/100W
AASHTO Designation		M 270 Grade 36	M 270 Grade 50	M 270 Grade 50W	A 709 Grade HPS 70W	M 270 Grades 100/100W	A 709 Grades 100/100W
Equivalent ASTM Designation		A 709 Grade 36	A 709 Grade 50	A 709 Grade 50W	A 709 Grade HPS 70W	M 270 Grades 100/100W	A 709 Grades 100/100W
Thickness of Plates		Up to 4" included	Up to 4" included	Up to 4" included	Up to 4" included	Up to 2 1/2" included	Over 2 1/2" to 4" included
Shapes		All Groups	All Groups	All Groups	N/A	N/A	N/A
Axial tension in members with no holes for high-strength bolts or rivets.		$0.55 F_y$	20,000	27,000	27,000	38,000	N/A
Use net section when member has any open holes larger than 1 1/4 inch diameter such as perforations.		$0.46 F_u$		N/A		51,000	46,000
Axial tension in members with holes for high-strength bolts or rivets and tension in extreme fiber of rolled shapes girders, and built-up sections subject to bending. Satisfy both Gross and Net Section criterion.		Gross Section ⁱ $0.55 F_y$	20,000	27,000	27,000	38,000	N/A
		Net Section $0.50 F_u$	29,000	32,500	35,000	45,000	N/A
		Net Section $0.46 F_u$		N/A		51,000	46,000
Axial compression, gross section: stiffeners of plate girders. Compression in splice material, gross section			20,000	27,000	27,000	38,000	55,000 49,000
Compression in extreme fibers of doubly symmetrical I- and H-shape members with compact flanges continuously connected to the web and bent about their weak axes (except members with the yield strength greater than 65,000 psi); solid round and square bars; and solid rectangular sections bent about their weak axes		$0.625 F_y$	22,000	31,000	31,000	43,000	62,000 62,000
Compression in extreme fibers of rolled shapes, girders, and built-up sections subject to bending. Gross section, when compression flange is:							
(A) Supported laterally its full length by embedment in concrete		$0.55 F_y$	20,000	27,000	27,000	38,000	55,000 49,000
(B) Partially supported or is unsupported ^{a, b}							

$$F_b = \frac{50 \times 10^6 C_b}{S_{xc}} \left(\frac{I_{yc}}{I} \right) \sqrt{0.772 \frac{J}{I_{yc}} + 9.87 \left(\frac{d}{I} \right)^2} \leq 0.55 F_y$$

+

Footnotes for Table 10.32.1A Allowable Stresses—Structural Steel (psi)

^a For the use of larger C_b values, see Structural Stability Research Council *Guide to Stability Design Criteria for Metal Structures*, 3rd Ed., pg. 135. If cover plates are used, the allowable static stress at the point of theoretical cutoff shall be as determined by the formula.

^b λ = length in inches, of unsupported flange between lateral connections, knee braces, or other points of support.

I_{yc} = moment of inertia of compression flange about the vertical axis in the plane of the web in.⁴

d = depth of girder, in.

$J = \frac{[(bt^3)_c + (bt^3)_t + Dt_w^3]}{3}$ where b and t represent the flange width and thickness of the compression and tension flange, respectively (in.⁴).

S_{xc} = section modulus with respect to compression flange (in.³).

^c E = modulus of elasticity of steel

r = governing radius of gyration

L = actual unbraced length

K = effective length factor (see Appendix C)

$F.S.$ = factor of safety = 2.12

For graphic representation of these formulas, see Appendix C.

The formulas do not apply to members with variable moment of inertia. Procedures for designing members with variable moments of inertia can be found in the following references: "Engineering Journal," American Institute of Steel Construction, January 1969, Volume 6, No. 1, and October 1972, Volume 9, No. 4; and "Steel Structures," by William McGuire, 1968, Prentice-Hall, Inc., Englewood Cliffs, New Jersey. For members with eccentric loading, see Article 10.36.

Singly symmetric and unsymmetric compression members, such as angles, or tees, and doubly symmetric compression members, such as cruciform or built-up members with very thin walls, may also require consideration of flexural-torsional and torsional buckling. Refer to the *Manual of Steel Construction*, Ninth Edition, 1989, American Institute of Steel Construction.

^d See also Article 10.32.4.

^e This shall apply to pins used primarily in axially loaded members, such as truss members and cable adjusting links. It shall not apply to pins used in members having rotation caused by expansion of deflection.

ⁱ When the area of holes deducted for high strength bolts or rivets is more than 15 percent of the gross area, that area in excess of 15 percent shall be deducted from the gross area in determining stress on the gross section. In determining gross section, any open holes larger than 1¹/₄ inch diameter, such as perforations, shall be deducted.

TABLE 10.32.3A Allowable Stresses for Low-Carbon Steel Bolts and Power Driven Rivets (psi)

Type of Fastener	Tension ^b	Bearing ^c	Shear Bearing-Type Connection ^b
(A) Low-Carbon Steel Bolts ^a Turned Bolts (ASTM A 307) Ribbed Bolts	18,000	20,000	11,000
(B) Power-Driven Rivets (rivets driven by pneumatically or electrically operated hammers are considered power driven)			
Structural Steel Rivet Grade 1 (ASTM A 502 Grade 1)	—	40,000	13,500
Structural Steel Rivet (high strength) Grade 2 (ASTM A 502 Grade 2)	—	40,000	20,000

- ^a ASTM A 307 bolts shall not be used in connections subject to fatigue.
- ^b Applies to fastener cross sectional area based upon nominal body diameter.
- ^c Applies to nominal diameter of fastener multiplied by the thickness of the metal.

TABLE 10.32.3B Allowable Stress for High-Strength Bolts or Connected Material (psi)

Load Condition	Allowable Stress
Applied Static Tension ^{a, b}	$0.315 F_u^d$
Shear, F_v , on bolt with threads included in shear plane ^c	$0.16 F_u^d$
Shear, F_v , on bolt with threads excluded from shear plane	$0.20 F_u^d$
Bearing, F_p , on connected material in standard, oversize, short-slotted holes in any direction, or long-slotted holes parallel to the applied bearing force	$\frac{0.5L_c F_u}{d} \leq F_u^{e,f,g}$
Bearing, F_p , on connected material in long-slotted holes perpendicular to the applied bearing force	$\frac{0.4L_c F_u}{d} \leq 0.8F_u^{e,f,g}$

- ^a Bolts must be tensioned to requirements of the Standard Specifications of California Department of Transportation
- ^b See Article 10.32.3.4 for bolts subject to tensile fatigue
- ^c In connection transmitting axial force whose length between extreme fasteners measured parallel to the line of force exceeds 50 inches, tabulated values shall be reduced 20 percent.
- ^d F_u = specified minimum tensile strength of the fastener given in Table 10.2C (psi)
- ^e F_u = specified minimum tensile strength of connected material (psi)
 L_c = clear distance between the holes or between the hole and the edge of the material in the direction of the applied bearing force (in.)
 d = nominal diameter of the bolt (in.)
- ^f Connection using high-strength bolts in slotted holes with the load applied in a direction other than approximately normal (between 80 and 100 degrees) to the axis of the hole and connections with bolts in oversized holes shall be designed for resistance against slip in accordance with Article 10.32.3.2.1.
- ^g Allowable bearing force for the connection is equal to the sum of the allowable bearing force for the individual bolts in the connection
- ^h AASHTO M 164 (ASTM A 325) and AASHTO M 253 (ASTM A 490) high-strength bolts are available in three types, designated as Types 1, 2, or 3. Type 3 shall be required on the plans when using unpainted AASHTO M 270 Grade 50W (ASTM A 709 Grade 50W).

10.32.3.2.1 In addition to the allowable stress requirements of Article 10.32.3.2 the force on a slip-critical connection as defined in Article 10.24.1.4 shall not exceed the allowable slip resistance (P_s) of the connection according to:

$$P_s = K_h \mu T_b A_n N_b N_s \quad (10-13)$$

where:

A_n = net cross section area of the bolt (in.²)

N_b = number of bolts in the joint

N_s = number of slip planes

T_b = required minimum bolt tension stress specified in the Standard Specifications of California Department of Transportation or equal to 70% of specified minimum tensile strength of bolts given in Table 10.2C (psi)

μ = slip coefficient specified in Table 10.32.3C

K_h = hole size factor specified in Table 10.32.3D

Class A, B or C surface conditions of the bolted parts as defined in Table 10.32.3C shall be used in joints designated as slip-critical except as permitted in Article 10.32.3.2.2.

10.32.3.2.2 Subject to the approval of the Engineer, coatings providing a slip coefficient less than 0.33 may be used provided the mean slip coefficient is established by test in accordance with the requirements of Article 10.32.3.2.3, and the slip resistance per unit area is established.

10.32.3.2.3 Paint, used on the faying surfaces of connections specified to be slip-critical, shall be qualified by test in accordance with "Test Method to Determine the Slip Coefficient for Coatings Used in Bolted Joints" as adopted by the Research Council on Structural Connections. See Appendix A of *Allowable Stress Design Specification for Structural Joints Using ASTM A325 or A490 Bolts* published by the Research Council on Structural Connections.

TABLE 10.32.3C Slip Coefficient μ

Class Types	Contact Surface of Bolted Parts	μ
Class A	Clean mill scale and blast-cleaned surfaces with Class A coating	0.33
Class B	Blast-cleaned surfaces and blast-cleaned surfaces with Class B coating	0.5
Class C	Hot-dip galvanized surfaces roughened by hand wired brushing after galvanizing	0.33

Note: Coatings classified as Class A or Class B include those coatings which provide a mean slip coefficient not less than 0.33 or 0.5, respectively, as determined by Testing Method to Determine the Slip Coefficient for Coatings Used in the Bolted Joints. See Article 10.32.3.2.3.

TABLE 10.32.3D Hole Size Factor Slip K_h

Hole Types	K_h
Standard	1.0
Oversize and Short-slotted	0.85
Long-slotted holes with the slot perpendicular to the direction of the force	0.70
Long-slotted holes with the slot parallel to the direction of the force	0.60

10.32.3.3 Applied Tension, Combined Tension and Shear

10.32.3.3.1 High-strength bolts preferably shall be used for fasteners subject to tension or combined tension and shear.

10.32.3.3.2 Bolts required to support applied load by means of direct tension shall be so proportioned that their average tensile stress computed on the basis of nominal bolt area will not exceed the appropriate stress in Table 10.32.3B. The applied load shall be the sum of the external load and any tension resulting from prying action. The tension due to the prying action shall be

$$Q = \left[\frac{3b}{8a} - \frac{t^3}{20} \right] T \quad (10-14)$$

where:

- + Q = the prying tension per bolt (taken as zero when negative) (lb.)
- + T = the direct tension per bolt due to external load (lb.)
- + a = distance from center of bolt under consideration to edge of plate (in.)
- + b = distance from center of bolt under consideration to toe of fillet of connected part (in.)
- + t = thickness of thinnest part connected (in.)

+ **10.32.3.3.3** For combined shear and tension in slip-critical joints using high-strength bolts where applied forces reduce the total clamping force on the friction plane, the shear stress, f_v (psi), shall meet the following requirement:

$$f_v \leq F_s (1 - 1.88 f_t / F_u) \quad (10-15)$$

where:

- + f_t = calculated tensile stress in the bolt including any stress due to prying action (psi)
- + F_s = allowable slip stress (psi)
- + $= K_h m \bar{f}_b$
- + F_u = specified minimum tensile strength of the bolt from Table 10.2C (psi)

+ **10.32.3.3.4** Where rivets or high-strength bolts in bearing type connections are subject to both shear and tension, the tensile stress shall not exceed the reduced allowable tensile stress obtained from the following equations. The combined stresses shall meet the requirement of Equation (10-18).

for $f_v / F_v \leq 0.33$

$$F'_t = F_t \quad (10-16)$$

for $f_v / F_v > 0.33$

$$F'_t = F_t \sqrt{1 - (f_v / F_v)^2} \quad (10-17)$$

$$f_v^2 + (k f_t)^2 \leq F_v^2 \quad (10-18) \quad +$$

where:

- + f_t = calculated tensile stress in rivet or bolt including any stress due to prying action (psi)
- + f_v = calculated shear stress in rivet or bolt (psi)
- + F_t = allowable tensile stress on rivet or bolt from Table 10.32.3A or Table 10.32.3B (psi)
- + F'_t = reduced allowable tensile stress on rivet or bolt due to the applied shear stress (psi)
- + F_v = allowable shear stress on rivet or bolt from Table 10.32.3A or Table 10.32.3B (psi)
- + k = a constant: 0.75 for rivets; 0.6 for high-strength bolts with threads excluded from shear plane

10.32.3.4 Fatigue

When subject to tensile fatigue loading, the tensile stress in the bolt due to the service load plus the prying force resulting from application of service load shall not exceed the following allowable stresses (psi). The nominal diameter of the bolt shall be used in calculating the bolt stress. The prying force shall not exceed 80 percent of the externally applied load.

Number of Cycles	AASHTO M 164 (ASTM A 325)	AASHTO M 235 (ASTM A 490)
Not more than 20,000	38,000	47,000
From 20,000 to 500,000	35,500	44,000
More than 500,000	27,500	34,000

10.32.4 Pins, Rollers, and Expansion Rockers

+ **10.32.4.1** The effective bearing area of a pin shall be its diameter multiplied by the thickness of the material on which it bears. When parts in contact have different yield strength, F_y shall be the smaller value.

+ **10.32.4.2** Design stresses for Steel Bars, Carbon Cold Finished Standard Quality, AASHTO M 169 (ASTM A 108), and Steel Forgings, Carbon and Alloy, for General Industrial Use, AASHTO M 102 (ASTM A 668), are given in Table 10.32.4.2A.



TABLE 10.32.4.2A Allowable Stresses—Steel Bars and Steel Forgings

AASHTO Designation with Size Limitations	—	M 102 To 20" in dia.	M 102 To 10" in dia.	M 102 To 20" in dia.
ASTM Designation Grade or Class	—	A 668 Class D	A 668 Class F	A 668 ^b Class G
Minimum Yield Strength, psi	F_y	37,500	50,000	50,000
Stress in Extreme Fiber, psi	$0.80F_y$	30,000	40,000	40,000
Shear, psi	$0.40F_y$	15,000	20,000	20,000
Bearing on Pins not Subject to Rotation, psi ^c	$0.80F_y$	30,000	40,000	40,000
Bearing on Pins Subject to Rotation, psi (such as used in rockers and hinges)	$0.40F_y$	15,000	20,000	20,000

^b May substitute rolled material of the same properties.

^c This shall apply to pins used primarily in axially loaded members, such as truss members and cable adjusting links. It shall not apply to pins used in members having rotation caused by expansion or deflection.

10.32.5 Cast Steel, Ductile Iron Castings, Malleable Castings, and Cast Iron

10.32.5.1 Cast Steel and Ductile Iron

10.32.5.1.1 For cast steel conforming to specifications for Steel Castings for Highway Bridges, AASHTOM 192 (ASTM A 486), Mild-to-Medium-Strength Carbon-Steel Castings for General Application, AASHTO M103 (ASTM A27), and Corrosion-Resistant Iron-Chromium, Iron-Chromium-Nickel and Nickel-Based Alloy Castings for General Application, AASHTO M 163 (ASTM A 743), and for Ductile Iron Castings (ASTM A 536), the allowable stresses shall be in accordance with Table 10.32.5.1A.

10.32.5.1.2 When in contact with castings or steel of a different yield strength, the allowable bearing stress of the material with the lower yield strength shall govern. For riveted or bolted connections, Article 10.32.3 shall govern.

10.32.5.2 Malleable Castings

Malleable castings shall conform to specifications for Malleable Iron Castings, ASTM A 47 Grade 35018.

The following allowable stresses (psi) and modulus of elasticity (psi) shall be used:

- Tension 18,000
- Bending in Extreme Fiber 18,000
- Modulus of Elasticity 25,000,000

10.32.5.3 Cast Iron

Cast iron castings shall conform to specifications for Gray Iron Castings, AASHTO M 105 (ASTM A 48), Class 30B. The following allowable stresses (psi) shall be used:

- Bending in Extreme Fiber 3,000
- Shear 3,000
- Direct Compression, short columns 12,000

10.32.5.4 Deleted



TABLE 10.32.5.1A Allowable Stresses—Cast Steel and Ductile Iron (psi)

AASHTO Designation	M 103	M 192	M 192		M 163	None
ASTM Designation	A 27	A 486	A 486		A 743	A 536
Class or Grade	70-36	70	90	120	CA-15	60-40-18
Minimum Yield Strength, F_y	36,000		60,000	95,000	65,000	40,000
Axial Tension	14,500		22,500	34,000	24,000	16,000
Tension in Extreme Fiber	14,500		22,500	34,000	24,000	16,000
Axial Compression, Short Columns	20,000		30,000	45,000	32,000	22,000
Compression in Extreme Fibers	20,000		30,000	45,000	32,000	22,000
Shear	09,000		13,500	21,000	14,000	10,000
Bearing, Steel Parts in Contact	30,000		45,000	68,000	48,000	33,000
Bearings on Pins not subject to Rotation	26,000		40,000	60,000	43,000	28,000
Bearings on Pins subject to Rotation (such as used in rockers and hinges)	13,000		20,000	30,000	21,500	14,000

10.32.6 Bearing on Masonry

10.32.6.1 The allowable bearing stress (psi) on the following types of masonry shall be:

- Granite800
- Sandstone and Limestone400

10.32.6.2 The above bridge seat stress will apply only where the edge of the bridge seat projects at least 3 inches (average) beyond the edge of shoe or plate. Otherwise, the stresses permitted will be 75 percent of the above amounts.

10.32.6.3 For allowable bearing stress on concrete masonry, refer to Article 8.15.2.1.3.

10.33 ROLLED BEAMS

10.33.1 General

10.33.1.1 Rolled beams, including those with welded cover plates, shall be designed by the moment of inertia method. Rolled beams with riveted cover plates shall be designed on the same basis as riveted plate girders.

10.33.1.2 The compression flanges of rolled beams supporting timber floors shall not be considered to be laterally supported by the flooring unless the floor and fastenings are specially designed to provide adequate support.

10.33.2 Bearing Stiffeners

Suitable stiffeners shall be provided to stiffen the webs of rolled beams at bearings when the calculated shear stress in the web adjacent to the bearing exceeds 75 percent of the allowable shear stress for girder webs. See the related provisions of Article 10.34.6.

10.34 PLATE GIRDERS

10.34.1 General

10.34.1.1 Girders shall be proportioned by the moment of inertia method. For members primarily in bending, the entire gross section shall be used when calculating tensile and compressive stresses. Holes for high-strength bolts or rivets and/or open holes not exceeding 1¼ inches, may be neglected provided the area removed from each flange does not exceed 15 percent of that flange. That area in excess of 15 percent shall be deducted from the gross area.

10.34.1.2 The compression flanges of plate girders supporting timber floors shall not be considered to be laterally supported by the flooring unless the floor and fastenings are specially designed to provide support.

10.34.2 Flanges

10.34.2.1 Welded Girders

10.34.2.1.1 Each flange may comprise a series of plates joined end to end by full penetration butt welds. Changes in flange areas may be accomplished by varying the thickness and/or width of the flange plate, or by adding cover plate. Varying the thickness and/or width of the flange plate is preferred. Where plates of varying thicknesses or widths are connected, the splice shall be made in accordance with Article 10.18 and welds ground smooth before attaching to the web. The compression-flange width, b , on fabricated I-shaped girders preferably shall not be less than 0.2 times the web depth, but in no case shall it be less than 0.15 times the web depth. If the area of the compression flange is less than the area of the tension flange, the minimum flange width may be based on 2 times the depth of the web in compression rather than the web depth. The compression-flange thickness, t , preferably shall not be less than 1.5 times the web thickness. The width-to-thickness ratio, b/t , of flanges subject to tension shall not exceed 24.

10.34.2.1.2 When cover plates are used, they shall be designed in accordance with Article 10.13.

+ *10.34.2.1.3* The width-thickness ratio (b/t) of compression flange plate shall not exceed the limiting values specified in Table 10.34.2A.

+ *10.34.2.1.4 Deleted*

TABLE 10.34.2A Limiting Width-Thickness Ratios for Compression Flanges of Plate Girders

Description of Component	Limiting (b/t)	When $f_b = 0.55 F_y$	
		F_y (psi)	Limiting b/t
Compression flange plate of noncomposite welded plate girders	$\frac{3,250}{\sqrt{f_b}} \leq 24$ (10-19)	36,000	23
		50,000	20
		70,000	17
		90,000	15
		100,000	14
Compression flange plate of composite welded plate girders	$\frac{3,860}{\sqrt{f_{d1}}} \leq 24$ (10-20)		
Outstanding legs of flange angles of noncomposite riveted or bolted girders	$\frac{1,625}{\sqrt{f_b}} \leq 12$ (10-21)	36,000	11.5
		50,000	10
		70,000	8.5
		90,000	7.5
		100,000	7.0
Outstanding legs of flange angles of composite riveted or bolted girders	$\frac{1,930}{\sqrt{f_{d1}}} \leq 12$ (10-22)		

b = flange plate width for welded plate girders or outstanding leg width of flange angles for riveted and bolted girders (in.)

f_b = calculated compressive bending stress in flange (psi)

f_{d1} = top flange compressive stress due to noncomposite dead load (psi)

F_y = specified minimum yield strength of the component under consideration (psi)

t = component plate thickness (in.)

10.34.2.1.5 In the case of a composite girder the width-thickness ratio (b/t) ratio of the top compression flange plate shall not exceed the limiting values specified in Table 10.34.2A.

10.34.2.2 Riveted or Bolted Girders

10.34.2.2.1 Flange angles shall form as large a part of the area of the flange as practicable. Side plates shall not be used except where flange angles exceeding $7/8$ inch in thickness otherwise would be required.

10.34.2.2.2 The width-thickness ratio (b/t) of outstanding legs of flange angles in compression, except those reinforced by plates, shall not exceed the limiting values specified in Table 10.34.2A

10.34.2.2.3 Deleted

10.34.2.2.4 In the case of a composite girder the width-thickness ratio (b/t) of outstanding legs of top flange angles in compression, except those reinforced by plates, shall not exceed the limiting values specified in Table 10.34.2A.

10.34.2.2.5 The gross area of the compression flange, except for composite design, shall be not less than the gross area of the tension flange.

10.34.2.2.6 Flange plates shall be of equal thickness, or shall decrease in thickness from the flange angles outward. No plate shall have a thickness greater than that of the flange angles.

10.34.2.2.7 At least one cover plate of the top flange shall extend the full length of the girder except when the flange is covered with concrete. Any cover plate that is not full length shall extend beyond the theoretical cutoff point far enough to develop the capacity of the plate or shall extend to a section where the stress in the remainder of the girder flange is equal to the allowable fatigue stress, whichever is greater. The theoretical cutoff point of the cover plate is the section at which the stress in the flange without that cover plate equals the allowable stress, exclusive of fatigue considerations.

10.34.2.2.8 The number of fasteners connecting the flange angles to the web plate shall be sufficient to develop the increment of flange stress transmitted to the flange angles, combined with any load that is applied directly to the flange.

10.34.2.2.9 Legs of angles 6 inches or greater in width, connected to web plates, shall have two lines of fasteners. Cover plates over 14 inches wide shall have four lines of fasteners.

10.34.3 Web Plates

10.34.3.1 Girders Not Stiffened Longitudinally

The girder without longitudinal stiffeners is usually preferred. The width-thickness ratio (D/t_w) of the web plate of plate girders without longitudinal stiffeners shall not exceed the limiting values specified in Table 10.34.3A.

10.34.3.1.1 Deleted

10.34.3.1.2 Deleted

10.34.3.2 Girders Stiffened Longitudinally

The width-thickness ratio (D/t_w) of the web plate of plate girders equipped with longitudinal stiffeners shall not exceed the limiting values specified in Table 10.34.3A.

10.34.3.2.1 Deleted

10.34.3.2.2 Deleted

TABLE 10.34.3A Limiting Width-Thickness Ratios for Web Plates of Plate Girders

Description of Web Plates	Limiting (D/t_w)	When $f_b = F_b$ or $f_v = F_v$	
		F_y (psi)	Limiting (D/t_w)
Without longitudinal stiffeners (See Figure 10.34.3A)	$\frac{23,000}{\sqrt{f_b}} \leq 170$ (10-23)	36,000 50,000 70,000 90,000 100,000	165 140 115 105 100
With longitudinal stiffeners (Note: When $f_b = F_b$, limiting width-thickness ratio (D/t_w) shall apply to a symmetrical girder stiffened with transverse stiffeners in combination with one longitudinal stiffener located a distance $D/5$ from the compression flange)	$\frac{4,050\sqrt{k}}{\sqrt{f_b}} \leq 340$ (10-24) for $\frac{d_s}{D_c} \geq 0.4$ $k = 5.17 \left(\frac{D}{d_s}\right)^2 \geq 9\left(\frac{D}{D_c}\right)^2$ for $\frac{d_s}{D_c} < 0.4$ $k = 11.64 \left(\frac{D}{D_c - d_s}\right)^2$ for symmetrical girder see Figure 10.34.3.1A	36,000 50,000 70,000 90,000 100,000	327 278 235 207 196
Without transverse stiffeners	$\frac{8,510}{\sqrt{f_v}} \leq 80$	36,000 50,000 70,000 90,000 100,000	78 66 56 50 47

D = depth of web or the clear unsupported distance between flange components (in.)

D_c = depth of web in compression calculated by summing the stresses from applicable stages of loadings (in.). In composite sections subjected to negative bending, D_c may be taken as the depth of the web in compression of the composite section without summing the stresses from various stage of loadings

d_s = distance from the centerline of a plate longitudinal stiffener or the gage line of an angle longitudinal stiffener to the inner surface or the leg of the compression flange component (in.)

f_b = calculated flange bending stress in the compression flange (psi)

f_v = calculated average shear stress in the gross section of the web plate (psi)

F_b = allowable bending stress (psi)

F_v = allowable shear stress (psi)

F_y = specified minimum yield strength of steel (psi)

k = buckling coefficient

t_w = web plate thickness (in.)

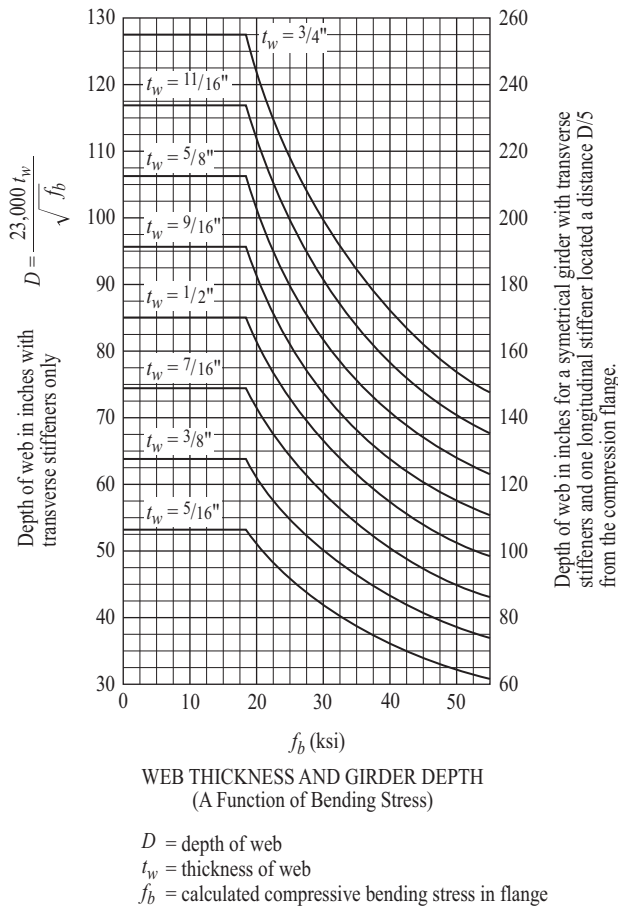

FIGURE 10.34.3.1A Web Thickness vs. Girder Depth for Non-Composite Symmetrical Sections

10.34.4 Transverse Intermediate Stiffeners

10.34.4.1 Transverse intermediate stiffeners may be omitted if the average calculated shearing stress in the gross section of the web plate at the point considered, f_v , is less than the value given by the following equation:

$$F_v = \frac{7.33 \times 10^7}{(D/t_w)^2} \leq \frac{F_y}{3} \quad (10-25)$$

where:

F_v = allowable shear stress (psi)

10.34.4.2 Where transverse intermediate stiffeners are required, the spacing of the transverse intermediate stiffener shall be such that the calculated shearing stress will not exceed the value given by the following equation (the maximum spacing is limited to $3D$ subject to the handling requirements below):

$$F_v = \frac{F_y}{3} \left[C + \frac{0.87(1-C)}{\sqrt{1+(d_o/D)^2}} \right] \quad (10-26)$$

The constant C is equal to the buckling shear stress divided by the shear yield stress, and is determined as follows:

for $\frac{D}{t_w} < \frac{6,000\sqrt{k}}{\sqrt{F_y}}$

$$C = 1.0$$

for $\frac{6,000\sqrt{k}}{\sqrt{F_y}} \leq \frac{D}{t_w} \leq \frac{7,500\sqrt{k}}{\sqrt{F_y}}$

$$C = \frac{6,000\sqrt{k}}{(D/t_w)\sqrt{F_y}} \quad (10-27)$$

for $\frac{D}{t_w} > \frac{7,500\sqrt{k}}{\sqrt{F_y}}$

$$C = \frac{4.5 \times 10^7 k}{(D/t_w)^2 \sqrt{F_y}} \quad (10-28)$$

where:

$$k = 5 + \frac{5}{(d_o/D)^2}$$

d_o = spacing of intermediate stiffener (in.)

F_y = specified minimum yield strength of the web plate (psi)

$(F_v/3)$ in Equation (10-26) can be replaced by the allowable shearing stress given in Table 10.32.1A.

Transverse stiffeners shall be required if D/t_w is greater than 150. The spacing of these stiffeners shall not exceed the handling requirement $D \left[\frac{260}{D/t_w} \right]^2$.

10.34.4.3 The spacing of the first intermediate stiffener at the simple support end of a girder shall be such that the shearing stress in the end panel shall not exceed the value given by the following equation (the maximum spacing is limited to $1.5D$):

$$F_v = \frac{CF_y}{3} \leq \frac{F_y}{3} \quad (10-29)$$

10.34.4.4 If a girder panel is subjected to simultaneous action of shear and bending moment with the magnitude of the shear stress higher than $0.6F_v$, the calculated bending stress shall not exceed the reduced allowable bending stress, F_s determined by the following equation:

$$F_s = \left(0.754 - \frac{0.34f_v}{F_v} \right) F_y \quad (10-30)$$

where:

f_v = average calculated shearing stress at the section; live load shall be the load to produce maximum moment at the section under consideration (psi)

F_v = allowable shear stress obtained from Equation (10-26) (psi)

F_s = reduced allowable bending stress (psi)

10.34.4.5 Where the calculated shear stress equals the allowable shear stress, transverse intermediate stiffeners may be omitted if the width-thickness ratio (D/t_w) of the web plate does not exceed the limiting values specified in Table 10.34.3A.

10.34.4.6 Intermediate stiffeners preferably shall be made of plates for welded plate girders and shall be made of angles for riveted plate girders. They may be in pairs, one stiffener fastened on each side of the web plate, with a tight fit at the compression flange. They may, however, be made of a single stiffener fastened to one side of the web plate. Stiffeners provided on only one side of the web must be welded to the compression flange and fitted tightly to the tension flange.

10.34.4.7 The width-thickness ratio (b/t_s) of the transverse stiffener shall not exceed the limiting values specified in Table 10.34.5A. The moment of inertia of any type of transverse stiffener with reference to the plane defined in Article 10.34.4.8 shall meet the following requirement:

$$I \geq d_o t_w^3 J \quad (10-31)$$

where:

$$J = 2.5 \left(\frac{D}{d_o} \right)^2 - 2 \geq 0.5 \quad (10-32)$$

I = minimum required moment of inertia of any type of transverse intermediate stiffener (in^4)

J = ratio of rigidity of one transverse stiffener to that of the web plate

d_o = spacing of transverse stiffeners (in.)

D = unsupported depth of web plate between flange components (in.)

t_w = thickness of the web plate (in.)

The gross cross-sectional area of intermediate transverse stiffeners, A (in.²) shall meet the following requirement:

$$A \geq \left[0.15B \frac{D}{t_w} (1-C) \left(\frac{f_v}{F_v} \right) - 18 \right] \frac{F_{yweb}}{F_{cr}} t_w^2 \quad (10-32a)$$

where:

$$F_{cr} = \frac{9,025,000}{\left(\frac{b'}{t_s} \right)^2} \leq F_{ystiffener} \quad (10-32b)$$

- b' = projecting width of the stiffener (in.)
- t_s = thickness of the stiffener (in.)
- F_{yweb} = specified minimum yield strength of the web (psi)
- $F_{ystiffener}$ = specified minimum yield strength of the stiffener (psi)
- B = 1.0 for stiffener pairs
1.8 for single angles and
2.4 for single plates
- C = constant computed by Article 10.34.4.2.

When values computed by Equation (10-32a) approach zero or are negative, then transverse stiffeners need only meet the requirements of Equation (10-31), and the requirements of Article 10.34.4.10.

10.34.4.8 When stiffeners are in pairs, the moment of inertia shall be taken about the centerline of the web plate. When single stiffeners are used, the moment of inertia shall be taken about the face in contact with the web plate.

10.34.4.9 Transverse intermediate stiffeners shall be preferably fitted tightly to the tension flange. If the intermediate stiffener is used for attaching a cross frame or diaphragm, a positive connection using either bolts or welds must be made to the tension flange. The distance between the end of the vertical weld on the stiffener to the web-to-flange weld shall be $4t_w$ but not less than $1\frac{1}{2}$ inches. Stiffeners at points of concentrated loading shall be placed in pairs and should be designed in accordance with Article 10.34.6.

10.34.4.10 The width of a plate or the outstanding leg of an angle intermediate stiffener shall not be less than 2 inches plus $\frac{1}{30}$ the depth of the girder, and it shall preferably not be less than $\frac{1}{4}$ the full width of the girder flange. The thickness of a plate or the outstanding leg of an angle intermediate stiffener shall not be less than $\frac{1}{16}$ its width.

10.34.5 Longitudinal Stiffeners

10.34.5.1 The optimum distance, d_s , of a plate longitudinal stiffener or the gage line of an angle longitudinal stiffener from the inner surface or the leg of the compression flange component is $D/5$ for a symmetrical girder. The optimum distance, d_s , for an unsymmetrical composite girder in positive-moment regions may be determined from the equation given below:

$$\frac{d_s}{D_{cs}} = \frac{1}{1 + 1.5 \sqrt{\frac{f_{DL+LL}}{f_{DL}}}} \quad (10-32c)$$

where:

- D_{cs} = depth of the web in compression of the non-composite steel beam or girder (in.)
- f_{DL} = non-composite dead-load stress in the compression flange (psi)
- f_{DL+LL} = total non-composite and composite dead load plus the composite live-load stress in compression flange at the most highly stressed section of the web (psi)

The optimum distance, d_s , of the stiffener in negative-moment regions of composite sections is $2D_c/5$, where D_c is the depth of the web in compression of the composite section at the most highly stressed section of the web.

The longitudinal stiffener shall be proportioned so that:

$$I = D t_w^3 \left(2.4 \frac{d_o^2}{D^2} - 0.13 \right) \quad (10-33)$$

where:

- I = required moment of inertia of the longitudinal stiffener about its edge in contact with the web plate (in.⁴)

D = unsupported distance between flange components (in.)

t_w = thickness of the web plate (in.)

d_o = spacing of transverse stiffeners (in.)

10.34.5.2 The width-thickness ratio (b'/t_s) of the longitudinal stiffener shall not exceed the limiting values specified in Table 10.34.5A.

10.34.5.3 The stress in the stiffener shall not be greater than the basic allowable bending stress for the material used in the stiffener.

TABLE 10.34.5A Limiting Width-Thickness Ratios for Stiffeners

Description of Component	Limiting (b'/t_s)
Longitudinal and Transverse stiffeners	$\frac{2,600}{\sqrt{F_y}}$ (10-34)
Bearing stiffeners	$\frac{2,180}{\sqrt{F_y}}$ (10-35) & (10-36)
Compression flange stiffeners	$\frac{2,600}{\sqrt{F_y}}$ (10-88)

b' = width of stiffener plate or outstanding legs of angle stiffener (in.)

F_y = specified minimum yield strength of stiffener (psi)

t_s = thickness of stiffener plate or outstanding legs of angle stiffener (in.)

10.34.5.4 Longitudinal stiffeners are usually placed on one side only of the web plate. They shall preferably be continuous where required. The termination and intersection of the longitudinal stiffener with transverse attachments shall consider the effects of fatigue. The interrupted element shall maintain the same strength characteristics as an uninterrupted element.

10.34.5.5 For longitudinally stiffened girders, transverse stiffeners shall be spaced a distance, d_o , according to shear capacity as specified in Article 10.34.4.2, but not more than 1.5 times the web depth. The handling requirement given in Article 10.34.4.2 shall not apply to longitudinally stiffened girders. The spacing of the first

transverse stiffener at the simple support end of a longitudinally stiffened girder shall be such that the shearing stress in the end panel does not exceed the value given in Article 10.34.4.3. The total web depth D shall be used in determining the shear capacity of longitudinally stiffened girders in Articles 10.34.4.2 and 10.34.4.3.

10.34.5.6 Transverse stiffeners for girder panels with longitudinal stiffeners shall be designed according to Article 10.34.4.7.

10.34.6 Bearing Stiffeners

10.34.6.1 Welded Girders

Over the end bearings of welded plate girders and over the intermediate bearings of continuous welded plate girders there shall be stiffeners. They shall extend as nearly as practicable to the outer edges of the flange plates. They shall be made of plates placed on both sides of the web plate. Bearing stiffeners shall be designed as columns, and their connection to the web shall be designed to transmit the entire end reaction to the bearings. For stiffeners consisting of two plates, the column section shall be assumed to comprise the two plates and a centrally located strip of the web plate whose width is equal to not more than 18 times its thickness. For stiffeners consisting of four or more plates, the column section shall be assumed to comprise the four or more plates and a centrally located strip of the web plate whose width is equal to that enclosed by the four or more plates plus a width of not more than 18 times the web plate thickness. (See Article 10.40 for Hybrid Girders.) The radius of gyration shall be computed about the axis through the centerline of the web plate. The stiffeners shall be ground to fit against the flange through which they receive their reaction, or attached to the flange by full penetration groove welds. Only the portions of the stiffeners outside the flange-to-web plate welds shall be considered effective in bearing. The width-thickness ratio (b'/t_s) of the bearing stiffener plates shall not exceed the limiting values specified in Table 10.34.5A.

The allowable compressive stress and the bearing pressure on the stiffeners shall not exceed the values specified in Article 10.32.

10.34.6.2 Riveted or Bolted Girders

Over the end bearings of riveted or bolted plate girders there shall be stiffener angles, the outstanding legs of which shall extend as nearly as practicable to the outer edge on the flange angle. Bearing stiffener angles shall be proportioned for bearing on the outstanding legs of flange angles, no allowance being made for the portions of the legs being fitted to the fillets of the flange angles. Bearing stiffeners shall be arranged, and their connections to the web shall be designed to transmit the entire end reaction to the bearings. They shall not be crimped.

The width-thickness ratio (b'/t_s) of the bearing stiffener angles shall not exceed the limiting values specified in Table 10.34.5A.

The allowable compressive stress and the bearing pressure on the stiffeners shall not exceed the values specified in Article 10.32.

10.35 TRUSSES

10.35.1 Perforated Cover Plates and Lacing Bars

The shearing force normal to the member in the planes of lacing or continuous perforated plates shall be assumed divided equally between all such parallel planes. The shearing force shall include that due to the weight of the member plus any other external force. For compression members, an additional shear force shall be added as obtained by the following formula:

$$V = \frac{P}{100} \left[\frac{100}{l/r+10} + \frac{(l/r)F_y}{3,300,000} \right] \quad (10-37)$$

where:

- V = normal shearing force (lb.)
- P = allowable compressive axial load on members (lb.)
- l = length of member (in.)
- r = radius of gyration of section about the axis perpendicular to plane of lacing or perforated plate (in.)
- F_y = specified minimum yield strength of type of steel being used (psi)

10.35.2 Compression Members

10.35.2.1 Compression members shall be so designed that the main elements of the section will be connected directly to the gusset plates, pins, or other members.

10.35.2.2 The center of gravity of a built-up section shall coincide as nearly as practicable with the center of the section. Preferably, segments shall be connected by solid webs or perforated cover plates.

10.35.2.3 The width-thickness ratio (b/t) of elements of compression members shall not exceed the limiting values specified in Table 10.35.2A.

10.35.2.4 Deleted

10.35.2.5 Deleted

10.35.2.6 Deleted

10.35.2.7 Deleted

10.35.2.8 Deleted

10.35.2.9 Deleted

10.35.2.10 Deleted

10.35.2.11 Deleted

TABLE 10.35.2A Limiting Width-Thickness Ratios for Compression Member Elements

Description of Component	Limiting (b/t)	When $f_a = 0.44 F_y$	
		F_y (psi)	Limiting b/t
Plates supported on one side, outstanding legs of angles and perforated plates—for outstanding plates, outstanding legs of angles, and perforated plates at the perforations	$\frac{1,625}{\sqrt{f_a}} \leq \begin{cases} 12 & \text{for main members} \\ 16 & \text{for secondary member} \end{cases}$ (10-38)	36,000	12
		50,000	11
		70,000	9
		90,000	8
		100,000	7.5
Plates supported on two edges or webs of main component segments—for members of box shape consisting of main plates, rolled sections, or made up component segments with cover plates	$\frac{4,000}{\sqrt{f_a}} \leq 45$ (10-39)	36,000	32
		50,000	27
		70,000	23
		90,000	20
		100,000	19
Solid cover plates supported on two edges or webs connecting main members or segments—for members of H or box shapes consisting of solid cover plates or solid webs connecting main plates or segments	$\frac{5,000}{\sqrt{f_a}} \leq 50$ (10-40)	36,000	40
		50,000	34
		70,000	28
		90,000	25
		100,000	24
Perforated cover plates supported on two edges—for members of box shapes consisting of perforated cover plates connecting main plates or segments, perforated cover plates supported on one side	$\frac{6,000}{\sqrt{f_a}} \leq 55$ (10-41)	36,000	48
		50,000	41
		70,000	34
		90,000	30
		100,000	29

b = distance between points of support (in.).

f_a = calculated compressive stress in the component under consideration (psi)

F_y = specified minimum yield strength of the component under consideration (psi)

t = component plate thickness (in.)

Note: The point of support shall be the inner line of fasteners or fillet welds connecting the plate to the main segment. For plates butt welded to the flange edge of rolled segments the point of support may be taken as the weld whenever the ratio of outstanding flange width to flange thickness of the rolled segment is less than seven. Otherwise, point of support shall be the root of flange of rolled segment. Terminations of the butt welds are to be ground smooth.

10.36 COMBINED STRESSES

+ All members subjected to both axial compression and flexure shall be proportioned to satisfy the following requirements:

$$\frac{f_a}{F_a} + \frac{C_{mx}f_{bx}}{\left(1 - \frac{f_a}{F'_e}\right)F_{bx}} + \frac{C_{my}f_{by}}{\left(1 - \frac{f_a}{F'_e}\right)F_{by}} \leq 1.0 \quad (10-42)$$

and

$$\frac{f_a}{0.472F_y} + \frac{f_{bx}}{F_{bx}} + \frac{f_{by}}{F_{by}} \leq 1.0 \text{ (at points of support)} \quad (10-43)$$

where:

$$F'_e = \frac{\pi^2 E}{F.S. (K_b L_b / r_b)^2} \quad (10-44)$$

- + f_a = calculated axial stress (psi)
- + f_{bx}, f_{by} = calculated compressive bending stress about the x axis and y axis, respectively (psi)
- + F_a = allowable axial if axial force alone exists, regardless of the plane of bending (psi)
- + F_{bx}, F_{by} = allowable compressive bending stress if bending moment alone exists about the x axis and the y axis, respectively, as evaluated according to Table 10.32.1A (psi)
- + F'_e = Euler buckling stress divided by a factor of safety (psi)
- + E = modulus of elasticity of steel (psi)
- + K_b = effective length factor in the plane of bending (see Appendix C);
- + L_b = actual unbraced length in the plane of bending (in.)
- + r_b = radius of gyration in the plane of bending (in.)
- + C_{mx}, C_{my} = coefficient about the x axis and y axis, respectively, whose value is taken from Table 10.36A;
- + $F.S.$ = factor of safety = 2.12.

TABLE 10.36A Bending-Compression Interaction Coefficients

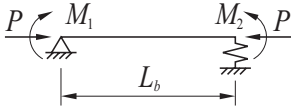
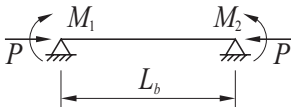
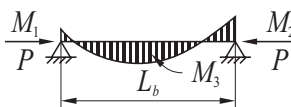
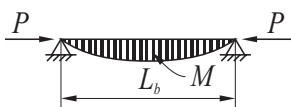
Loading Conditions	Remarks	C_m
Computed moments maximum at end; joint translation not prevented		0.85
+ Computed moments maximum at end; no transverse loading, joint translation prevented		$\left[(0.4) \frac{M_1}{M_2} + 0.6 \right]$
Transverse loading; joint translation prevented		0.85
Transverse loading; joint translation prevented		1.0

M_1 = smaller end moment.
 M_1/M_2 is positive when member is bent in single curvature.
 M_1/M_2 is negative when member is bent in reverse curvature.
 In all cases C_m may be conservatively taken equal to 1.0.

$$F_e = \frac{\pi^2 E}{\left(\frac{KL}{r} \right)^2} \quad (10-46) \quad +$$

10.37 SOLID RIB ARCHES

10.37.1 Moment Amplification and Allowable Stress

+ **10.37.1.1** The calculated compressive bending stress due to live load plus impact loading that are determined by an analysis which neglects arch rib deflection shall be increased by an amplification factor A_F :

$$A_F = \frac{1}{1 - \frac{1.7T}{AF_e}} \quad (10-45)$$

where:

+ T = arch rib thrust at the quarter point from dead plus live plus impact loading (lb.)
 + F_e = Euler buckling stress (psi)

L = one half of the length of the arch rib (in)
 A = area of cross section (in.²)
 r = radius of gyration (in.)
 K = effective length factor of the arch rib +

K Values for Use in Calculating F_e and F_a +

Rise to Span Ratio	3-Hinged Arch	2-Hinged Arch	Fixed Arch
0.1 - 0.2	1.16	1.04	0.70
0.2 - 0.3	1.13	1.10	0.70
0.3 - 0.4	1.16	1.16	0.72

10.37.1.2 The arch rib shall be proportioned to satisfy the following requirement:

$$\frac{f_a}{F_a} + \frac{f_b}{F_b} \leq 1.0 \quad (10-47)$$

where:

- + f_a = the calculated axial stress (psi)
- + f_b = the calculated bending stress, including moment amplification, at the extreme fiber (psi)
- + F_a = the allowable axial stress (psi)
- + F_b = the allowable bending stress (psi)

10.37.1.3 For buckling in the vertical plane:

$$F_a = \frac{F_y}{F.S.} \left[1 - \frac{\left(\frac{KL}{r} \right)^2 F_y}{4\pi^2 E} \right] \quad (10-48)$$

- + where KL as defined above and $F.S.$ is factor of safety = 2.12.

10.37.1.4 The effects of lateral slenderness should be investigated. Tied arch ribs, with the tie and roadway suspended from the rib, are not subject to moment amplification, and F_a shall be based on an effective length equal to the distance along the arch axis between suspenders, for buckling in the vertical plane. However, the smaller cross-sectional area of cable suspenders may result in an effective length slightly longer than the distance between suspenders.

10.37.2 Web Plates

- + **10.37.2.1** The width-thickness ratio (D/t_w) of the web plates shall not exceed the limiting values specified in Table 10.37.2A.

- + **10.37.2.2** If one longitudinal stiffener is used at mid-depth of the web, the moment of inertia of the stiffener about an axis parallel to the web and at the base of the stiffener shall meet the following requirement:

$$I_s \geq 0.75Dt_w^3 \quad (10-51)$$

- + **10.37.2.3** If two longitudinal stiffeners are used at the one-third points of the web depth D , the moment of inertia of each stiffener shall meet the following requirement: +

$$I_s \geq 2.2Dt_w^3 \quad (10-53) \quad +$$

- + **10.37.2.4** The width-thickness ratio (b'/t_s) of any outstanding element of the web stiffeners shall not exceed the limiting values specified in Table 10.37.2A. +

- + **10.37.2.5** Deleted +

10.37.3 Flange Plates

- + The width-thickness ratio (b'/t_f) of flange plates shall not exceed the limiting values specified in Table 10.37.2A. +

- + **10.37.3.1** Deleted +

- + **10.37.3.2** Deleted +

TABLE 10.37.2A Limiting Width-Thickness Ratios for Solid Rib Arches

Description of Component		Width Thickness Ratio	Limiting Width-Thickness Ratio
Web Plates	Without longitudinal stiffeners	D/t_w	$\frac{5,000}{\sqrt{f_a}} \leq 60$ (10-49)
	With one longitudinal stiffener at the one-third point of the web depth		$\frac{7,500}{\sqrt{f_a}} \leq 90$ (10-50)
	With two longitudinal stiffeners at the one-third point of the web design		$\frac{10,000}{\sqrt{f_a}} \leq 120$ (10-52)
	Outstanding element of stiffeners	b'/t_s	$\frac{1,625}{\sqrt{f_a + f_b/3}} \leq 12$ (10-54)
Flange Plates	Web plate equations apply between limits $0.2 \leq \frac{f_b}{\sqrt{f_a + f_b/3}} \leq 0.7$		(10-55)
	Plates between webs	b'/t_f	$\frac{4,250}{\sqrt{f_a + f_b}} \leq 47$ (10-56)
	Overhang plates		$\frac{1,625}{\sqrt{f_a + f_b}} \leq 12$ (10-57)

b' = width of flange plate or width of outstanding element of web stiffeners (in.)

f_a = calculated axial compressive stress in the component under consideration (psi)

f_b = calculated compressive bending stress in the component under consideration (psi)

t_f = flange plate thickness (in.)

t_s = web stiffener outstanding element thickness (in.)

t_w = web plate thickness (in.)

+ **10.38 COMPOSITE BEAMS AND GIRDERS**

+

10.38.1 General

+ **10.38.1.1** This section pertains to structures composed of steel beams or girders with concrete slabs connected by shear connectors.

10.38.1.2 General specifications pertaining to the design of concrete and steel structures shall apply to structures utilizing composite girders where such specifications are applicable. Composite girders and slabs shall be designed and the stresses computed by the composite moment of inertia method and shall be consistent with the predetermined properties of the various materials used.

+ **10.38.1.3** The ratio of the modulus of elasticity of steel (29,000,000 psi) to those of normal weight concrete ($W = 145$ pcf) of various design strengths shall be as follows:

+ f'_c = specified compressive strength of concrete as determined by cylinder tests at the age of 28 days (psi)

+ n = ratio of modulus of elasticity of steel to that of concrete. The value of n , as a function of the specified compressive strength of concrete, shall be assumed as follows:

$f'_c = 2,000 - 2,300$	$n = 11$
2,400 - 2,800	$n = 10$
2,900 - 3,500	$n = 9$
3,600 - 4,500	$n = 8$
4,600 - 5,900	$n = 7$
6,000 or more	$n = 6$

+ **10.38.1.4** The effect of creep shall be considered in the design of composite girders which have dead loads acting on the composite section. In such structures, bending stresses and horizontal shears produced by dead loads acting on the composite section shall be computed for n as given above or for this value multiplied by 3, which ever gives the higher bending stresses and shears.

10.38.1.5 If concrete with expansive characteristics is used, composite design should be used with caution and provision must be made in the design to accommodate the expansion.

10.38.1.6 Composite sections in simple spans and the positive moment regions of continuous spans should

preferably be proportioned so that the neutral axis lies below the top surface of the steel beam. Concrete on the tension side of the neutral axis shall not be considered in calculating resisting moments. In the negative moment regions of continuous spans, only the slab reinforcement can be considered to act compositely with the steel beams in calculating resisting moments. Mechanical anchorages shall be provided in the composite regions to develop stresses on the plane joining the concrete and the steel. Concrete on the tension side of the neutral axis may be considered in computing moments of inertia for deflection calculations, for determining stiffness used in calculating moments and shears, and for computing fatigue stress ranges and fatigue shear ranges as permitted under the provisions of Article 10.3.1 and 10.38.5.1.

10.38.1.7 The steel beams or girders, especially if not supported by intermediate falsework, shall be investigated for stability and strength for the loading applied during the time the concrete is in place and before it has hardened. The casting or placing sequence specified in the plans for the composite concrete deck shall be considered when calculating the moments and shears on the steel section. The maximum flange compression stress shall not exceed the value specified in Table 10.32.1A for partially supported or unsupported compression flanges multiplied by a factor of 1.4, but not exceed $0.55F_y$. The sum of the non-composite and composite dead-load shear stresses in the web shall not exceed the shear-buckling capacity of the web multiplied by a factor of 1.35, nor the allowable shear stress, as follows:

$$F_v = 0.45CF_y \leq 0.33F_y \quad (10-57a)$$

where:

C = constant specified in Article 10.34.4.2.

10.38.2 Shear Connectors

10.38.2.1 The mechanical means used at the junction of the girder and slab for the purpose of developing the shear resistance necessary to produce composite action shall conform to the specifications of the respective materials. The shear connectors shall be of types that permit a thorough compaction of the concrete in order to ensure that their entire surfaces are in contact with the concrete. They shall be capable of resisting both horizontal and vertical movement between the concrete and the steel.

10.38.2.2 The capacity of stud and channel shear connectors welded to the girders is given in Article 10.38.5. Channel shear connectors shall have at least 3/16-inch fillet welds placed along the heel and toe of the channel.

10.38.2.3 The clear depth of concrete cover over the tops of the shear connectors shall be not less than 2 inches. Shear connectors shall penetrate at least 2 inches above bottom of slab.

10.38.2.4 The clear distance between the edge of a girder flange and the edge of the shear connectors shall be not less than 1 inch. Adjacent stud shear connectors shall not be closer than 4 diameters center to center.

10.38.3 Effective Flange Width

10.38.3.1 In composite girder construction the assumed effective width of the slab as a T-beam flange shall not exceed the following:

- (1) One-fourth of the span length of the girder.
- (2) The distance center to center of girders.
- (3) Twelve times the least thickness of the slab.

10.38.3.2 For girders having a flange on one side only, the effective flange width shall not exceed one-twelfth of the span length of the girder, or six times the thickness of the slab, or one-half the distance center to center of the next girder.

10.38.4 Stresses

10.38.4.1 Maximum compressive and tensile stresses in girders that are not provided with temporary supports during the placing of the permanent dead load shall be the sum of the stresses produced by the dead loads acting on the steel girders alone and the stresses produced by the superimposed loads acting on the composite girder. When girders are provided with effective intermediate supports that are kept in place until the concrete has attained 75 percent of its required 28-day strength, the dead and live load stresses shall be computed on the basis of the composite section.

10.38.4.2 A continuous composite bridge may be built with shear connectors either in the positive moment regions or throughout the length of the bridge. The positive moment regions may be designed with composite sections as in simple spans. Shear connectors shall be

provided in the negative moment portion in which the reinforcement steel embedded in the concrete is considered a part of the composite section. In case the reinforcement steel embedded in the concrete is not used in computing section properties for negative moments, shear connectors need not be provided in these portions of the spans, but additional anchorage connectors shall be placed in the region of the point of dead load contra-flexure in accordance with Article 10.38.5.1.3. Shear connectors shall be provided in accordance with Article 10.38.5.

10.38.4.3 The minimum longitudinal reinforcement including the longitudinal distribution reinforcement must equal or exceed one percent of the cross-sectional area of the concrete slab whenever the longitudinal tensile stress in the concrete slab due to either the construction loads or the design loads exceeds f_t specified in Article 8.15.2.1.1. The area of the concrete slab shall be equal to the structural thickness times the entire width of the bridge deck. The required reinforcement shall be No. 6 bars or smaller spaced at not more than 12 inches. Two-thirds of this required reinforcement is to be placed in the top layer of slab. Placement of distribution steel as specified in Article 3.24.10 is waived.

10.38.4.4 When shear connectors are omitted from the negative moment region, the longitudinal reinforcement shall be extended into the positive moment region beyond the anchorage connectors at least 40 times the reinforcement diameter. For epoxy-coated bars, the length to be extended into the positive moment region beyond the anchorage connectors should be modified to comply with Article 8.25.2.3.

10.38.5 Shear

10.38.5.1 Horizontal Shear

The maximum pitch of shear connectors shall not exceed 24 inches except over the interior supports of continuous beams where wider spacing may be used to avoid placing connectors at locations of high stresses in the tension flange.

Resistance to horizontal shear shall be provided by mechanical shear connectors at the junction of the concrete slab and the steel girder. The shear connectors shall be mechanical devices placed transversely across the flange

of the girder spaced at regular or variable intervals. The shear connectors shall be designed for fatigue* and checked for design strength.

10.38.5.1.1 Fatigue

The range of horizontal shear shall be computed by the formula:

$$S_r = \frac{V_r Q}{I} \quad (10-58)$$

where:

- + S_r = range of horizontal shear (lb/in.), at the junction of the slab and girder at the point in the span under consideration
- + V_r = range of shear due to live loads and impact (lb.); at any section, the range of shear shall be taken as the difference in the minimum and maximum shear envelopes (excluding dead loads)
- + Q = statical moment about the neutral axis of the composite section of the transformed concrete area (in³). Between points of dead-load contraflexure, the static moment about the neutral axis of the composite section of the area of reinforcement embedded in the concrete may be used unless the transformed concrete area is considered to be fully effective for the negative moment in computing the longitudinal ranges of stress.
- + I = moment of inertia of the transformed short-term composite section (in⁴). Between points of dead-load contraflexure, the moment of inertia of the steel girder including the area of reinforcement embedded in the concrete may be used unless the transformed concrete area is considered to be fully effective for the negative moment in computing the longitudinal ranges of stress.

(In the formula, the concrete area is transformed into an equivalent area of steel by dividing the effective concrete flange width by the modular ratio, n .)

* Reference is made to the paper titled "Fatigue Strength of Shear Connectors," by Roger G. Slutter and John W. Fisher, in *Highway Research Record*, No. 147, published by the Highway Research Board, Washington, D.C., 1966.

The allowable range of horizontal shear, Z_r (lb.) on an individual connector is as follows:

Channels:

$$Z_r = Bw \quad (10-59)$$

Welded studs (for $H/d \geq 4$):

$$Z_r = \alpha d^2 \quad (10-60)$$

where:

- + w = length of a channel shear connector (in.), measured in a transverse direction on the flange of a girder
- + d = diameter of stud (in.)
- + α = 13,000 for 100,000 cycles
10,600 for 500,000 cycles
7,850 for 2,000,000 cycles
5,500 for over 2,000,000 cycles;
- + B = 4,000 for 100,000 cycles
3,000 for 500,000 cycles
2,400 for 2,000,000 cycles
2,100 for over 2,000,000 cycles;
- + H = height of stud (in.)

The required pitch of shear connectors is determined by dividing the allowable range of horizontal shear of all connectors at one transverse girder cross-section (ΣZ_r) by the horizontal range of shear S_r , but not to exceed the maximum pitch specified in Article 10.38.5.1. Over the interior supports of continuous beams the pitch may be modified to avoid placing the connectors at locations of high stresses in the tension flange provided that the total number of connectors remains unchanged.

10.38.5.1.2 Design Strength

The number of connectors so provided for fatigue shall be checked to ensure that adequate connectors are provided for design strength.

+ The number of shear connectors required shall meet
+ the following requirement:

$$N_1 \geq \frac{P}{\phi S_u} \quad (10-61)$$

where:

N_1 = number of connectors between points of maximum positive moment and adjacent end supports

+ S_u = design strength of the shear connector as given
+ below (lb.)

ϕ = reduction factor = 0.85;

+ P = horizontal shear force transferred by shear con-
+ nectors as defined hereafter as P_1 or P_2 .

At points of maximum positive moment, the force in the slab is taken as the smaller value of the formulas:

$$P_1 = A_s F_y \quad (10-62)$$

or

$$P_2 = 0.85 f'_c b t_s \quad (10-63)$$

where:

A_s = total area of the steel section including cover - plates (in.²)

+ F_y = specified minimum yield strength of the steel
+ being used (psi)

+ f'_c = specified compressive strength of concrete at
+ age of 28 days (psi)

+ b = effective flange width given in Article 10.38.3 (in.)

+ t_s = thickness of the concrete slab (in.)

+ The number of connectors, N_2 , required between the
+ points of maximum positive moment and points of adja-
+ cent maximum negative moment shall meet the follow-
+ ing requirement:

$$N_2 \geq \frac{P + P_3}{\phi S_u} \quad (10-64)$$

At points of maximum negative moment the force in the slab is taken as:

$$P_3 = A_s^r F_y^{r*} \quad (10-65)$$

where:

A_s^r = total area of longitudinal reinforcing steel at the interior support within the effective flange width (in.²)

+ F_y^{r*} = specified minimum yield strength of the rein-
+ forcing steel (psi)

+ The design strength of the shear connector is given
+ as follows:

Channels:

$$S_u = 550 \left(h + \frac{t}{2} \right) W \sqrt{f'_c} \quad (10-66)$$

Welded studs (for $H/d > 4$):

$$S_u = 0.4d^2 \sqrt{f'_c E_c} \leq 60,000 A_{sc} \quad (10-67)$$

where:

E_c = modulus of elasticity of the concrete (psi)
+ $E_c = w^{3/2} 33 \sqrt{f'_c}$ (10-68)

S_u = design strength of individual shear connector
+ (lb.)

h = average flange thickness of the channel flange
+ (in.)

t = thickness of the web of a channel (in.)

W = length of a channel shear connector (in.)

f'_c = specified compressive strength of the concrete
+ at 28 days (psi)

d = diameter of stud (in.)

w = unit weight of concrete (pcf)

A_{sc} = area of welded stud cross section (in.²)

10.38.5.1.3 Additional Connectors to Develop Slab Stresses

The number of additional connectors required at points of contraflexure when reinforcing steel embedded in the concrete is not used in computing section properties for negative moments shall be computed by the formula:

$$N_c = \frac{A_r^s f_r}{Z_r} \quad (10-69)$$

where:

- N_c = number of additional connectors for each beam at point of contraflexure
- + A_r^s = total area of longitudinal slab reinforcing steel for each beam over interior support (in.²)
- + f_r = range of stress due to live load plus impact in the slab reinforcement over the support (psi) (in lieu of more accurate computations, f_r may be taken as equal to 10,000 psi);
- + Z_r = allowable range of horizontal shear on an individual shear connector (lb.)

The additional connectors, N_c , shall be placed adjacent to the point of dead load contraflexure within a distance equal to one-third the effective slab width, i.e., placed either side of this point or centered about it. It is preferable to locate field splices so that they clear the connectors.

+ 10.38.5.2 Vertical Shear

The intensity of shearing stress in a composite girder may be determined on the basis that the web of the steel girder carries the total external shear, neglecting the effects of the steel flanges and of the concrete slab. The shear may be assumed to be uniformly distributed throughout the gross area of the web.

10.38.6 Deflection

10.38.6.1 The provisions of Article 10.6 in regard to deflections from live load plus impact also shall be applicable to composite girders.

10.38.6.2 When the girders are not provided with falsework or other effective intermediate support during

the placing of the concrete slab, the deflection due to the weight of the slab and other permanent dead loads added before the concrete has attained 75 percent of its required 28-day strength shall be computed on the basis of noncomposite action.

10.39 COMPOSITE BOX GIRDERS

10.39.1 General

10.39.1.1 This section pertains to the design of simple and continuous bridges of moderate length supported by two or more single cell composite box girders. The distance center-to-center of flanges of each box should be the same and the average distance center-to-center of flanges of adjacent boxes shall be not greater than 1.2 times and not less than 0.8 times the distance center-to-center of flanges of each box. In addition to the above, when nonparallel girders are used, the distance center-to-center of adjacent flanges at supports shall be no greater than 1.35 times and not less than 0.65 times the distance center-to-center of flanges of each box. The cantilever overhang of the deck slab, including curbs and parapets, shall be limited to 60 percent of the average distance center-to-center of flanges of adjacent boxes, but shall in no case exceed 6 feet. +

10.39.1.2 The provisions of these Specifications shall govern where applicable, except as specifically modified by Articles 10.39.1 through 10.39.8.

10.39.2 Lateral Distribution of Loads for Bending Moment

10.39.2.1 The live load bending moment for each box girder shall be determined by applying to the girder, the fraction W_L of a wheel load (both front and rear), determined by the following equation:

$$W_L = 0.1 + 1.7R + \frac{0.85}{N_w} \quad (10-70)$$

where:

$$R = \frac{N_w}{\text{Number of Box Girders}} \quad (10-71)$$

- + $N_w = W_c/12$ reduced to the nearest whole number
- + $W_c =$ roadway width between curbs (ft.), or barriers if curbs are not used.
- + R shall not be less than 0.5 or greater than 1.5.

10.39.2.2 The provision of Article 3.12, Reduction of Load Intensity, shall not apply in the design of box girders when using the design load W_L given by the above equation.

+ 10.39.3 Web Plates

10.39.3.1 Vertical Shear

The design shear V_w for a web shall be calculated using the following equation:

$$V_w = \frac{V_v}{\cos\theta} \quad (10-72)$$

where:

- + $V_v =$ vertical shear (lb.)
- $\theta =$ angle of inclination of the web plate to the vertical.

10.39.3.2 Secondary Bending Stresses

10.39.3.2.1 Web plates may be plumb (90° to bottom of flange) or inclined. If the inclination of the web plates to a plane normal to bottom flange is no greater than 1 to 4, and the width of the bottom flange is no greater than 20 percent of the span, the transverse bending stresses resulting from distortion of the span, and the transverse bending stresses resulting from distortion of the girder cross section and from vibrations of the bottom plate need not be considered. For structures in this category transverse bending stresses due to supplementary loadings, such as utilities, shall not exceed 5,000 psi.

10.39.3.2.2 For structures exceeding these limits, a detailed evaluation of the transverse bending stresses due to all causes shall be made. These stresses shall be limited to a maximum stress or range of stress of 20,000 psi.

10.39.4 Bottom Flange Plates

10.39.4.1 General

The tension flange and the compression flange shall be considered completely effective in resisting bending if its width does not exceed one-fifth the span length. If the flange plate width exceeds one-fifth of the span, an amount equal to one-fifth of the span only shall be considered effective. Effective flange plate width shall be used to calculate the flange bending stress. Full flange plate width shall be used to calculate the allowable compressive bending stress.

10.39.4.1.2 Deleted

10.39.4.2 Compression Flanges Unstiffened

10.39.4.2.1 For unstiffened compression flanges, the calculated bending stress shall not exceed the allowable bending stress, F_b (psi), determined by either of the following equations:

for $\frac{b}{t} \leq \frac{6,140}{\sqrt{F_y}}$

$$F_b = 0.55F_y \quad (10-73)$$

for $\frac{6,140}{\sqrt{F_y}} < \frac{b}{t} \leq \frac{13,300}{\sqrt{F_y}}$

$$F_b = 0.55F_y - 0.224F_y \left[1 - \sin \left(\frac{\pi}{2} \frac{13,300 - \frac{b\sqrt{F_y}}{t}}{7,160} \right) \right] \quad (10-74)$$

for $\frac{b}{t} \geq \frac{13,300}{\sqrt{F_y}}$

$$F_b = 57.6 \left(\frac{t}{b} \right)^2 \times 10^6 \quad (10-75)$$

+ where:

+ b = flange width between webs (in.)

+ t = flange thickness (in.)

+ 10.39.4.2.2 Deleted

+ 10.39.4.2.3 Deleted

10.39.4.2.4 The b/t ratio preferably should not exceed 60 except in areas of low stress near points of dead load contraflexure.

+ 10.39.4.2.5 If the b/t ratio exceeds 45, longitudinal stiffeners may be considered.

+ 10.39.4.2.6 Deleted

10.39.4.3 Compression Flanges Stiffened Longitudinally*

+ 10.39.4.3.1 Longitudinal stiffeners shall be at equal spacings across the flange width and shall be proportioned so that the moment of inertia of each stiffener about an axis parallel to the flange and at the base of the stiffener, I_s (in.⁴) shall meet the following requirement:

$$+ I_s \geq \phi t_f^3 w \quad (10-76)$$

where:

+ ϕ = 0.07 $k^3 n^4$ for values of n greater than 1;

+ ϕ = 0.125 k^3 for a value of $n = 1$;

t_f = thickness of the flange (in.)

+ w = width of flange between longitudinal stiffeners or distance from a web to the nearest longitudinal stiffener (in.)

n = number of longitudinal stiffeners;

k = buckling coefficient which shall not exceed 4.

+ 10.39.4.3.2 For the longitudinally stiffened flange, including stiffeners, the calculated bending stress shall not exceed the allowable bending stress, F_b (psi), determined by either of the following equations:

$$+ \text{for } \frac{w}{t} \leq \frac{3,070\sqrt{k}}{\sqrt{F_y}}$$

$$F_b = 0.55F_y \quad (10-77) \quad +$$

$$\text{for } \frac{3,070\sqrt{k}}{\sqrt{F_y}} < \frac{w}{t} \leq \text{smaller of } \{60\} \text{ or } \left\{ \frac{6,650\sqrt{k}}{\sqrt{F_y}} \right\} \quad +$$

$$F_b = 0.55F_y - 0.224F_y \left[1 - \sin \left(\frac{\pi}{2} \frac{6,650\sqrt{k} - \frac{w\sqrt{F_y}}{t}}{3,580\sqrt{k}} \right) \right] \quad +$$

$$(10-78)$$

$$\text{for } \frac{6,650\sqrt{k}}{\sqrt{F_y}} \leq \frac{w}{t} \leq 60 \quad +$$

$$F_b = 14.4k \left(\frac{t}{w} \right)^2 \times 10^6 \quad (10-79) \quad +$$

10.39.4.3.3 Deleted

10.39.4.3.4 Deleted

10.39.4.3.5 When longitudinal stiffeners are used, it is preferable to have at least one transverse stiffener placed near the point of dead load contraflexure. The stiffener should have a size equal to that of a longitudinal stiffener.

10.39.4.3.6 If the longitudinal stiffeners are placed at their maximum w/t ratio to be designed for the basic allowable design stresses of $0.55F_y$ and the number of longitudinal stiffeners exceeds 2, then transverse stiffeners should be considered.

10.39.4.3.7 Deleted

* In solving these equations a value of k between 2 and 4 generally should be assumed.

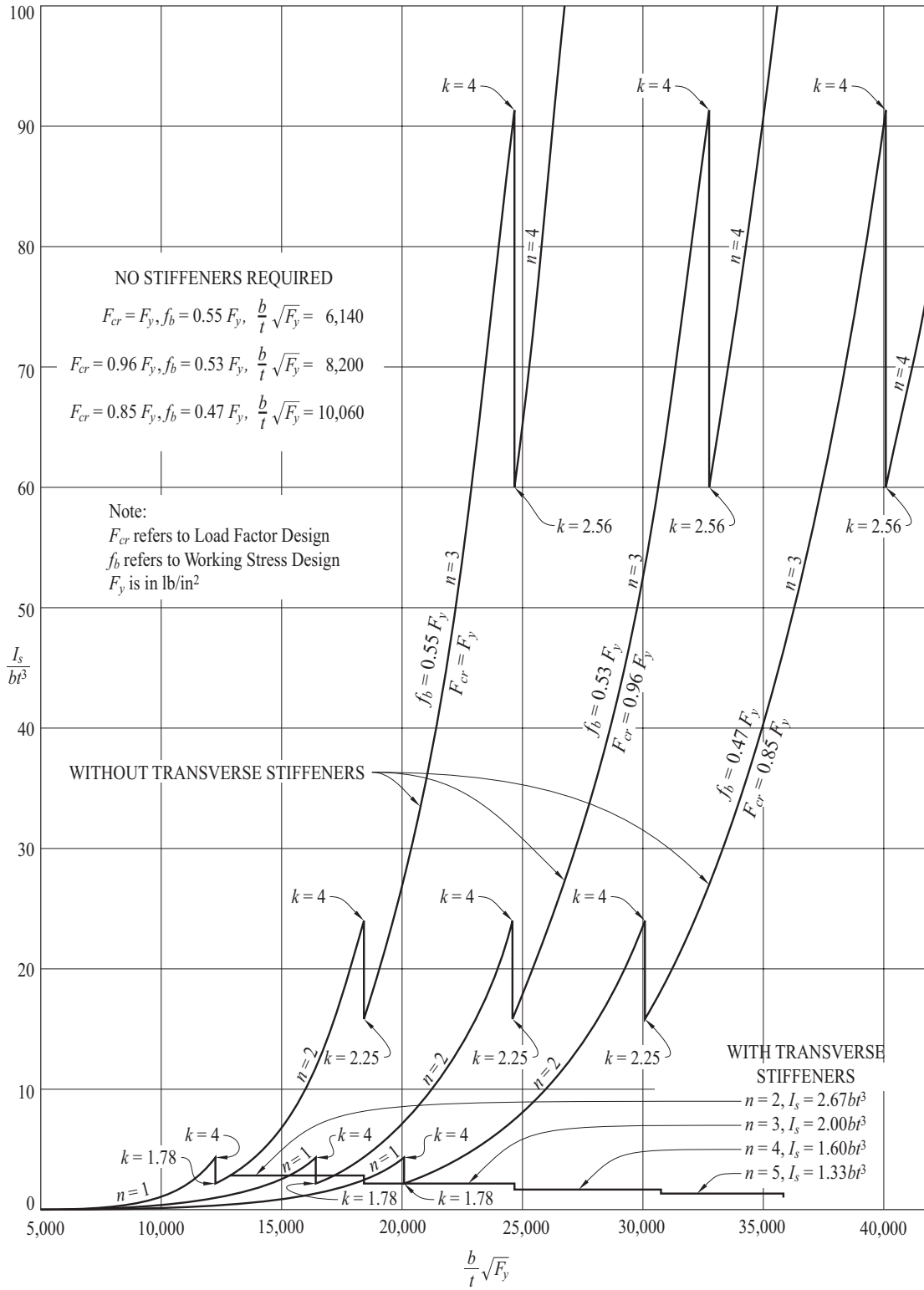

FIGURE 10.39.4.3A Longitudinal Stiffeners—Box Girder Compression Flange

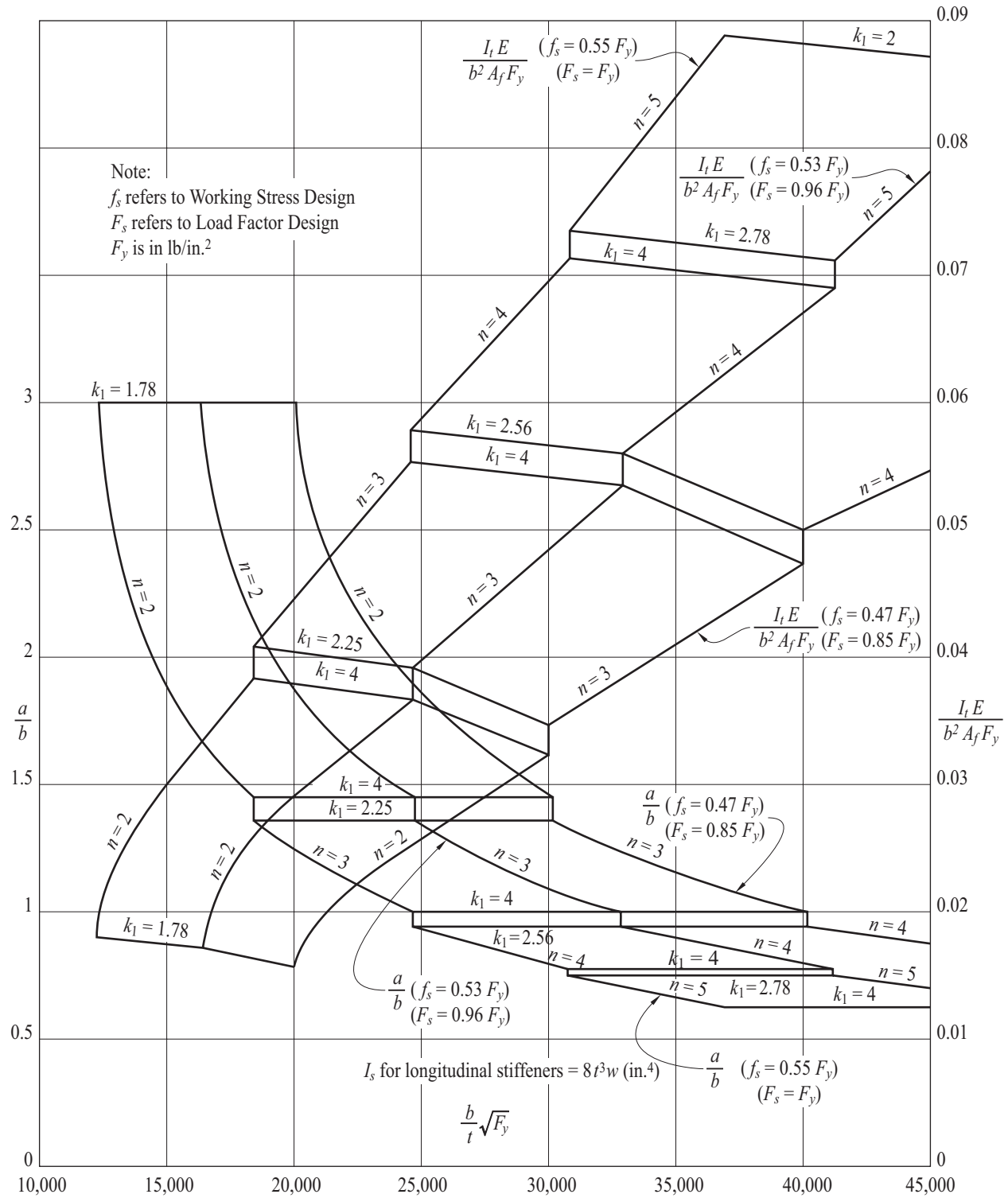

FIGURE 10.39.4.3B Spacing and Size of Transverse Stiffeners (for Flange Stiffened Longitudinally and Transversely)

10.39.4.4 Compression Flanges Stiffened Longitudinally and Transversely

10.39.4.4.1 The longitudinal stiffeners shall be at equal spacings across the flange width and shall be proportioned so that the moment of inertia of each stiffener about an axis parallel to the flange and at the base of the stiffeners meet the following requirement:

$$I_s \geq 8t_f^3 w \quad (10-80)$$

10.39.4.4.2 The transverse stiffeners shall be proportioned so that the moment of inertia of each stiffener about an axis through the centroid of the section and parallel to its bottom edge meets the following requirement:

$$I_t \geq 0.10 (n + 1)^3 w^3 \frac{f_s}{E} \frac{A_f}{d_o} \quad (10-81)$$

where:

A_f = area of bottom flange including longitudinal stiffeners (in.²)

d_o = spacing of transverse stiffeners (in.)

f_s = maximum longitudinal bending stress in the flange of the panels on either side of the transverse stiffeners (psi)

E = modulus of elasticity of steel (psi)

10.39.4.4.3 For the flange, including stiffeners, the calculated bending stress shall not exceed the allowable bending stress, F_b (psi), determined by either of the following equations:

$$\text{for } \frac{w}{t} \leq \frac{3,070\sqrt{k_1}}{\sqrt{F_y}}$$

$$F_b = 0.55F_y \quad (10-82)$$

$$\text{for } \frac{3,070\sqrt{k_1}}{\sqrt{F_y}} < \frac{w}{t} \leq \text{smaller of } \{60\} \text{ or } \left\{ \frac{6,650\sqrt{k_1}}{\sqrt{F_y}} \right\}$$

$$F_b = 0.55F_y - 0.224F_y \left[1 - \sin \left(\frac{\pi}{2} \frac{6,650\sqrt{k_1} - \frac{w\sqrt{F_y}}{t}}{3,580\sqrt{k_1}} \right) \right] \quad (10-83)$$

$$\text{for } \frac{6,650\sqrt{k_1}}{\sqrt{F_y}} \leq \frac{w}{t} \leq 60$$

$$F_b = 14.4k_1 \left(\frac{t}{w} \right)^2 \times 10^6 \quad (10-84)$$

where:

$$k_1 = \frac{[1 + (a/b)^2]^2 + 87.3}{(n+1)^2 (a/b)^2 [1 + 0.1(n+1)]} \quad (10-85)$$

10.39.4.4.4 Deleted

10.39.4.4.5 Deleted

10.39.4.4.6 The maximum value of the buckling coefficient, k_1 , shall be 4. When k_1 has its maximum value, the transverse stiffeners shall have a spacing, a , equal to or less than $4w$. If the ratio a/b exceeds 3, transverse stiffeners are not necessary.

10.39.4.4.7 The transverse stiffeners need not be connected to the flange plate but shall be connected to the webs of the box and to each longitudinal stiffener. The connection to the web shall be designed to resist the vertical force determined by the formula:

$$R_w = \frac{F_y S_s}{2b} \quad (10-86)$$

where:

S_s = section modulus of the transverse stiffener (in.³)

10.39.4.4.8 The connection to each longitudinal stiffener shall be designed to resist the vertical force determined by the formula:

$$R_s = \frac{F_y S_s}{nb} \quad (10-87)$$

10.39.4.5 Compression Flange Stiffeners, General

- + 10.39.4.5.1 The width-thickness ratio (b'/t_s) of any outstanding element of the flange stiffeners shall not
- + exceed the limiting values specified in Table 10.34.5A.

10.39.4.5.2 Longitudinal stiffeners shall be extended to locations where the maximum stress in the flange does not exceed that allowed for base metal adjacent to or connected by fillet welds.

+ 10.39.5 Flange to Web Welds

- + The total effective thickness of the web-flange welds shall be not less than the thickness of the web. Regardless of the type weld used, welds shall be deposited on both sides of the connecting flange or web plate.

10.39.6 Diaphragms

10.39.6.1 Diaphragms, cross-frames, or other means shall be provided within the box girders at each support to resist transverse rotation, displacement, and distortion.

10.39.6.2 Intermediate diaphragms or cross-frames are not required for steel box girder bridges designed in accordance with this specification.

10.39.7 Lateral Bracing

Generally, no lateral bracing system is required between box girders. A horizontal wind load of 50 pounds per square foot shall be applied to the area of the superstructure exposed in elevation. Half of the resulting force shall be applied in the plane of the bottom flange. The section assumed to resist the horizontal load shall consist of the bottom flange acting as a web and 12 times the thickness of the webs acting as flanges. A lateral bracing system shall be provided if the combined stresses due to the specified horizontal force and dead load of steel and deck exceed 150 percent of the allowable design stress.

10.39.8 Access and Drainage

Consistent with climate, location, and materials, consideration shall be given to the providing of manholes, or other openings, either in the deck slab or in the steel box for form removal, inspection, maintenance, drainage, etc.

10.40 HYBRID GIRDERS

10.40.1 General

10.40.1.1 This section pertains to the design of girders that utilize a lower strength steel in the web than in one or both of the flanges. It applies to composite and noncomposite plate girders, and composite box girders. At any cross section where the bending stress in either flange exceeds 55 percent of minimum specified yield strength of the web steel, the compression-flange area shall not be less than the tension-flange area. The top-flange area shall include the transformed area of any portion of the slab or reinforcing steel that is considered to act compositely with the steel girder.

10.40.1.2 The provisions of these Specifications, shall govern where applicable, except as specifically modified by Articles 10.40.1 through 10.40.4.

10.40.2 Allowable Stresses

10.40.2.1 Bending

10.40.2.1.1 The bending stress in the web may exceed the allowable stress for the web steel provided that the stress in each flange does not exceed the allowable stress from Articles 10.3 or 10.32 for the steel in that flange multiplied by the reduction factor, R .

$$R = 1 - \frac{\beta\psi(1-\alpha)^2(3-\psi+\psi\alpha)}{6+\beta\psi(3-\psi)} \quad (10-89)$$

(See Figures 10.40.2.1A and 10.40.2.1B)

where:

α = specified minimum yield strength of the web divided by the specified minimum yield strength of the tension flange;*

β = area of the web divided by the area of the tension flange;*

* Bottom flange of orthotropic deck bridge

ψ = distance from the outer edge of the tension flange* to the neutral axis (of the transformed section for composite girders) divided by the depth of the steel section.

10.40.2.1.2 The bending stress in the concrete slab in composite girders shall not exceed the allowable stress for the concrete multiplied by R .

10.40.2.1.3 R shall be taken 1.0 at sections where the bending stress in both flanges does not exceed the allowable stress for the web.

10.40.2.1.4 Longitudinal web stiffness preferably shall not be located in yielded portions of the web.

10.40.2.2 Shear

The design of the web for a hybrid girder shall be in compliance with the specification Articles 10.34.3 except that Equation (10-26) of Article 10.34.4.2 for the allowable average shear stress in the web of transversely stiffened non-hybrid girders shall be replaced by the following equations for the allowable average shear stress in the web of transversely stiffened hybrid girders:

$$F_v = \frac{CF_y}{3} \leq \frac{F_y}{3} \quad (10-90)$$

where:

+ F_y = specified minimum yield strength of the web (psi)

The provisions of Article 10.34.4.4 and the equation for A in Article 10.34.4.7 are not applicable to hybrid girders.

10.40.2.3 Fatigue

Hybrid girders shall be designed for the allowable fatigue stress range given in Article 10.3, Table 10.3.1A.

10.40.3 Plate Thickness Requirements

In calculating the maximum width-to-thickness ratio of the flange plate according to Article 10.34.2, f_b shall be taken as the lesser of the calculated bending stress in the compression flange divided by the reduction factor, R , or the allowable bending stress for the compression flange.

* Bottom flange of orthotropic deck bridge

10.40.4 Bearing Stiffener Requirements

In designing bearing stiffeners at interior supports of continuous hybrid girders for which α is less than 0.7, no part of the web shall be assumed to act in bearing.

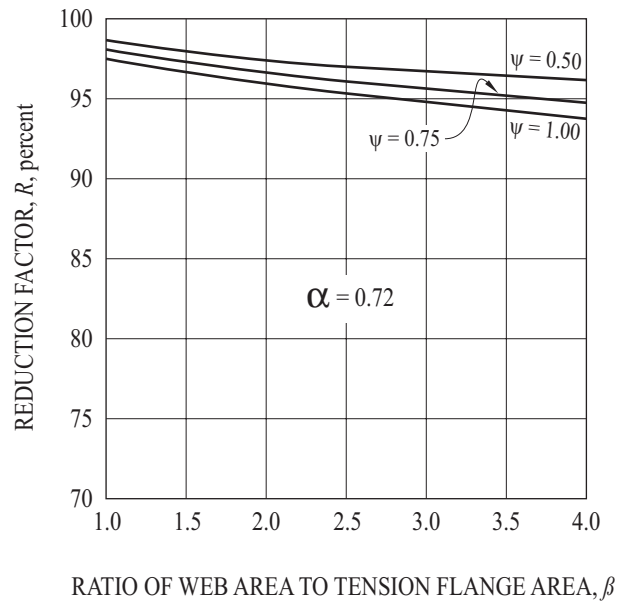

Figure 10.40.2.1A

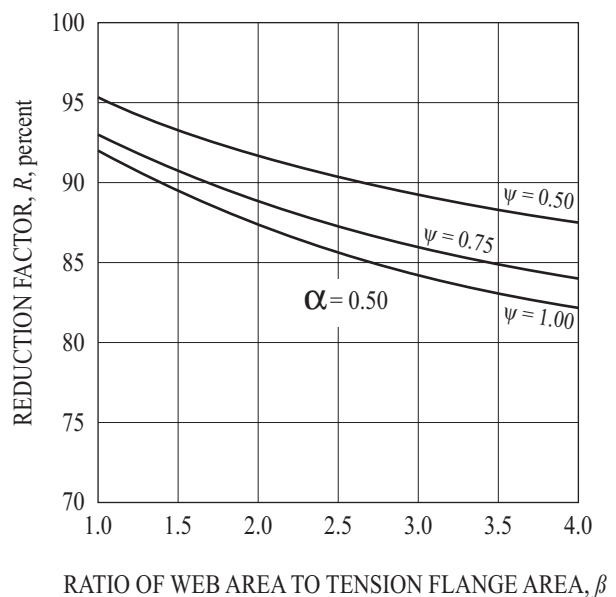

Figure 10.40.2.1B

10.41 ORTHOTROPIC-DECK SUPERSTRUCTURES

10.41.1 General

10.41.1.1 This section pertains to the design of steel bridges that utilize a stiffened steel plate as a deck. Usually the deck plate is stiffened by longitudinal ribs and transverse beams; effective widths of deck plate act as the top flanges of these ribs and beams. Usually the deck including longitudinal ribs, acts as the top flange of the main box or plate girders. As used in Articles 10.41.1 through 10.41.4.10, the terms rib and beam refer to sections that include an effective width of deck plate.

+ **10.41.1.2** The provisions of these Specifications, shall govern where applicable, except as specifically modified by Articles 10.41.1 through 10.41.4.10.

An appropriate method of elastic analysis, such as the equivalent-orthotropic-slab method or the equivalent-grid method, shall be used in designing the deck. The equivalent stiffness properties shall be selected to correctly simulate the actual deck. An appropriate method of elastic analysis, such as the thin-walled-beam method, that accounts for the effects of torsional distortions of the cross-sectional shape shall be used in designing the girders of orthotropic-deck box-girder bridges. The box-girder design shall be checked for lane or truck loading arrangements that produce maximum distortional (torsional) effects.

+ **10.41.1.3** For the preferred design method (Strength Design), see Article 10.60.

10.41.2 Wheel Load Contact Area

The wheel loads specified in Article 3.7 shall be uniformly distributed to the deck plate over the rectangular area defined below:

Wheel Load (kip)	Width Perpendicular to Traffic (in.)	Length in Direction of Traffic (in.)
8	$20 + 2t$	$8 + 2t$
12	$20 + 2t$	$8 + 2t$
16	$24 + 2t$	$8 + 2t$

In the above table, t is the thickness of the wearing surface (in.)

10.41.3 Effective Width of Deck Plate

10.41.3.1 Ribs and Beams

The effective width of deck plate acting as the top flange of a longitudinal rib or a transverse beam may be calculated by accepted approximate methods.*

10.41.3.2 Girders

10.41.3.2.1 The full width of deck plate may be considered effective in acting as the top flange of the girders if the effective span of the girders is not less than: (1) 5 times the maximum distance between girder webs and (2) 10 times the maximum distance from edge of the deck to the nearest girder web. The effective span shall be taken as the actual span for simple spans and the distance between points of contraflexure for continuous spans. Alternatively, the effective width may be determined by accepted analytical methods.

10.41.3.2.2 The effective width of the bottom flange of a box girder shall be determined according to the provisions of Article 10.39.4.1.

10.41.4 Allowable Stresses

10.41.4.1 Local Bending Stresses in Deck Plate

The term local bending stresses refers to the stresses caused in the deck plate as it carries a wheel load to the ribs and beams. The local transverse bending stresses caused in the deck plate by the specified wheel load plus 30-percent impact shall not exceed 30,000 psi unless a higher allowable stress is justified by a detailed fatigue analysis or by applicable fatigue-test results. For deck configurations in which the spacing of transverse beams is at least 3 times the spacing of longitudinal-rib webs, the local longitudinal and transverse bending stresses in the deck plate need not be combined with the other bending stresses covered in Articles 10.41.4.2 and 10.41.4.3.

* Design Manual for "Orthotropic Steel Plate Deck Bridges," AISC, 1963, or "Orthotropic Bridges, Theory and Design," by M.S. Troitsky, Lincoln Arc Welding Foundation, 1967.

10.41.4.2 Bending Stresses in Longitudinal Ribs

The total bending stresses in longitudinal ribs due to a combination of (1) bending of the rib and (2) bending of the girders may exceed the allowable bending stresses in Article 10.32 by 25 percent. The bending stress due to each of the two individual modes shall not exceed the allowable bending stresses in Article 10.32.

10.41.4.3 Bending Stresses in Transverse Beams

The bending stresses in transverse beams shall not exceed the allowable bending stresses in Article 10.32.

10.41.4.4 Intersections of Ribs, Beams, and Girders

Connections between ribs and the webs of beams, holes in the webs of beams to permit passage of ribs, connections of beams to the webs of girders, and rib splices may affect the fatigue life of the bridge when they occur in regions of tensile stress. Where applicable, the number of cycles of maximum stress and the allowable fatigue stresses given in Article 10.3 shall be applied in designing these details; elsewhere, a rational fatigue analysis shall be made in designing the details. Connections between webs of longitudinal ribs and the deck plate shall be designed to sustain the transverse bending fatigue stresses caused in the webs by wheel loads.

10.41.4.5 Thickness of Plate Elements

10.41.4.5.1 Longitudinal Ribs and Deck Plate

Plate elements comprising longitudinal ribs, and deck-plate elements between webs of these ribs, shall meet the minimum thickness requirements of Article 10.35.2. The quantity f_a may be taken as 75 percent of the sum of the compressive stresses due to (1) bending of the rib and (2) bending of the girder, but not less than the compressive stress due to either of these two individual bending modes.

10.41.4.5.2 Girders and Transverse Beams

Plate elements of box girders, plate girders, and transverse beams shall meet the requirements of Articles 10.34.2 to 10.34.6 and 10.39.4.

10.41.4.6 Maximum Slenderness of Longitudinal Ribs

The slenderness, L/r , of a longitudinal rib shall not exceed the value given by the following formula unless it can be shown by a detailed analysis that overall buckling of the deck will not occur as a result of compressive stress induced by bending of the girders:

$$\left(\frac{L}{r}\right)_{\max} = 1,000 \sqrt{\frac{1,500}{F_y} - \frac{2,700f}{F_y}} \quad (10-91) \quad +$$

where:

- L = distance between transverse beams (in.) +
- r = radius of gyration about the horizontal centroidal axis of the rib including an effective width of deck plate (in.) +
- f = maximum compressive stress in the deck plate as a result of the deck acting as the top flange of the girders; this stress shall be taken as positive (psi) +
- F_y = specified minimum yield strength of rib material (psi) +

10.41.4.7 Diaphragms

Diaphragms, cross frames, or other means shall be provided at each support to transmit lateral forces to the bearings and to resist transverse rotation, displacement, and distortion. Intermediate diaphragms or cross frames shall be provided at locations consistent with the analysis of the girders. The stiffness and strength of the intermediate and support diaphragms or cross frames shall be consistent with the analysis of the girders.

10.41.4.8 Stiffness Requirements

10.41.4.8.1 Deflections

The deflections of ribs, beams, and girders due to live load plus impact may exceed the limitations in Article 10.6 but preferably shall not exceed $1/500$ of their span. The calculation of the deflections shall be consistent with the analysis used to calculate the stresses.

To prevent excessive deterioration of the wearing surface, the deflection of the deck plate due to the specified wheel load plus 30-percent impact preferably

shall be less than $\frac{1}{300}$ of the distance between webs of ribs. The stiffening effect of the wearing surface shall not be included in calculating the deflection of the deck plate.

10.41.4.8.2 Vibrations

The vibrational characteristics of the bridge shall be considered in arriving at a proper design.

10.41.4.9 Wearing Surface

A suitable wearing surface shall be adequately bonded to the top of the deck plate to provide a smooth, nonskid riding surface and to protect the top of the plate against corrosion and abrasion. The wearing surface material shall provide (1) sufficient ductility to accommodate, without cracking or debonding, expansion and contraction imposed by the deck plate, (2) sufficient fatigue strength to withstand flexural cracking due to deck-plate deflections, (3) sufficient durability to resist rutting, shoving, and wearing, (4) imperviousness to water and motor-vehicle fuels and oils, and (5) resistance to deterioration from deicing salts, oils, gasolines, diesel fuels, and kerosenes.

10.41.4.10 Closed Ribs

Closed ribs without access holes for inspection, cleaning, and painting are permitted. Such ribs shall be sealed against the entrance of moisture by continuously welding (1) the rib webs to the deck plate, (2) splices in the ribs, and (3) diaphragms, or transverse beam webs, to the ends of the ribs.

Part D
Strength Design Method

Load Factor Design

10.42 SCOPE

- + Load factor design is the preferred method of proportioning structural members for multiples of the design loads. To ensure serviceability and durability, consideration is given to the control of permanent deformations under overloads, to the fatigue characteristics under service loadings, and to the control of live load deflections under service loadings.

10.43 LOADS

10.43.1 Service live loads are vehicles which may operate on a highway legally without special load permit.

- + **10.43.2** For design purposes, the service loads are taken as the dead, live, and impact loadings described in Section 3 – Loads.

10.43.3 Overloads are the live loads that can be allowed on a structure on infrequent occasions without causing permanent damage. For design purposes, the maximum overload is taken as $5(L + I)/3$.

10.43.4 The maximum loads are the loadings specified in Article 10.47.

10.44 DESIGN THEORY

10.44.1 The moments, shears and other forces shall be determined by assuming elastic behavior of the structure except as modified in Article 10.48.1.3.

10.44.2 The members shall be proportioned by the methods specified in Articles 10.48 through 10.56 so that their computed maximum strengths shall be at least equal to the total effects of design loads multiplied by their respective load factors specified in Article 3.2.

10.44.3 Service behavior shall be investigated as specified in Articles 10.57 through 10.59.

10.45 ASSUMPTIONS

10.45.1 Strain in flexural members shall be assumed directly proportional to the distance from the neutral axis.

10.45.2 Stress in steel below the yield strength, F_y , of the grade of steel used shall be taken as 29,000,000 psi times the steel strain. For strain greater than that corresponding to the yield strength, F_y , the stress shall be considered independent of strain and equal to the yield strength, F_y . This assumption shall apply also to the longitudinal reinforcement in the concrete floor slab in the region of negative moment when shear connectors are provided to ensure composite action in this region.

10.45.3 At maximum strength the compressive stress in the concrete slab of a composite beam shall be assumed independent of strain and equal to $0.85 f'_c$.

10.45.4 Tensile strength of concrete shall be neglected in flexural calculations, except as permitted under the provisions of Articles 10.57.2, 10.58.1 and 10.58.2.

10.46 DESIGN STRESS FOR STRUCTURAL STEEL

The design stress for structural steel shall be the specified minimum yield strength, F_y , of the steel used as set forth in Article 10.2. +

10.47 MAXIMUM DESIGN LOADS

The maximum moments, shears or forces to be sustained by a load-carrying member shall be computed from the formulas shown in Article 3.2. Each part of the structure shall be proportioned for the group loads that are applicable and the maximum design required by the group loading combinations shall be used. +

10.48 FLEXURAL MEMBERS

Flexural members are subject to the following requirements in this article in addition to any applicable requirements from Articles 10.49 through 10.61 that may supersede these requirements. The compression-flange width, b , on fabricated I-shaped girders preferably shall not be less than 0.2 times the web depth, but in no case shall it be less than 0.15 times the web depth. If the area of the compression flange is less than the area of the tension flange, the minimum flange width may be based on 2 times the depth of the web in compression rather than

the web depth. The compression-flange thickness, t , preferably shall not be less than 1.5 times the web thickness. The width-to-thickness ratio, b/t , of flanges subject to tension shall not exceed 24.

10.48.1 Compact Sections

Sections of properly braced constant-depth flexural members without longitudinal web stiffeners, without holes in the tension flange and with high resistance to local buckling qualify as compact sections.

Sections of rolled or fabricated flexural members meeting the requirements of Article 10.48.1.1 below shall be considered compact sections and the design bending strength shall be computed as:

$$M_u = F_y Z \quad (10-92)$$

where:

- F_y = specified minimum yield strength of the steel being used (psi)
- Z = plastic section modulus* (in.³)

10.48.1.1 Compact sections shall meet the following requirements: (for certain frequently used steels these requirements are listed in Table 10.48.1.2A).

(a) Compression flange:

$$\frac{b}{t} \leq \frac{4,110}{\sqrt{F_y}} \quad (10-93)$$

where:

- b = compression flange width (in.)
- t = flange thickness (in.)

(b) Web thickness:

$$\frac{D}{t_w} \leq \frac{19,230}{\sqrt{F_y}} \quad (10-94)$$

where:

- D = clear distance between the flanges (in.)
- t_w = web thickness (in.)

When both b/t and D/t_w exceed 75% of the above limits, the following interaction equation shall apply

$$\frac{D}{t_w} + 4.68 \left(\frac{b}{t} \right) \leq \frac{33,650}{\sqrt{F_{yf}}} \quad (10-95)$$

where:

- F_{yf} = specified minimum yield strength of compression flange (psi)

(c) Lateral bracing for compression flange:

$$\frac{L_b}{r_y} \leq \frac{[3.6 - 2.2(M_1/M_u)] \times 10^6}{F_y} \quad (10-96)$$

where:

- L_b = distance between points of bracing of the compression flange (in.)
- r_y = radius of gyration of the steel section with respect to the Y-Y axis (in.)
- M_1 = smaller moment at the end of the unbraced length of the member (lb-in.)
- M_u = design strength from Equation (10-92) at the other end of the unbraced length: (M_1/M_u) is positive when moments cause single curvature between brace points (lb-in.). (M_1/M_u) is negative when moments cause reverse curvature between brace points.

The required lateral bracing shall be provided by braces capable of preventing lateral displacement and twisting of the main members or by embedment of the top and sides of the compression flange in concrete.

(d) Maximum axial compression:

* Values for rolled sections are listed in the *Manual of Steel Construction*, Ninth Edition, 1989, American Institute of Steel Construction, Appendix D shows the methods of computing Z as presented in the Commentary of AISI Bulletin 15.

$$P \leq 0.15F_y A \quad (10-97)$$

where:

+ A = area of the cross section (in.²)

Members with axial loads in excess of $0.15F_y A$ should be designed as beam-columns as specified in Article 10.54.2.

10.48.1.2 Article 10.48.1 is applicable to steels with a demonstrated ability to reach M_p . Steels such as AASHTO M 270 Grades 36, 50 and 50W (ASTM A 709 Grades 36, 50 and 50W) and ASTM A 709, Grade HPS 70W meet these requirements. The limitations set forth in Article 10.48.1 are given in Table 10.48.1.2A.

TABLE 10.48.1.2A Limitations for Compact Sections

F_y (psi)	36,000	50,000	70,000
b/t	21.6	18.4	15.0
D/t_w	101	86	70
$L_b/r_y (M_1/M_u = 0^*)$	100	72	51
$L_b/r_y (M_1/M_u = 1^*)$	39	28	20

For values of M_1/M_u other than 0 and 1, use Equation (10-96).

10.48.1.3 In the design of a continuous beam with compact negative-moment support sections of AASHTO M 270 Grade 36, 50 and 50W (ASTM A 709 Grade 36, 50 and 50W) steel complying with the provision of Article 10.48.1.1, negative moments over such supports at Overload and Maximum Load determined by elastic analysis may be reduced by a maximum of 10 percent. Such reduction shall be accompanied by an increase in moments throughout adjacent spans statically equivalent and opposite in sign to the decrease of the negative moments at the adjacent supports. For example, the increase in moment at the center of the span shall equal the average decrease of the moments at the two adjacent supports. The reduction shall not apply to the negative moment of a cantilever. This 10-percent redistribution of moment shall not apply to compact sections of ASTM A 709 Grade HPS 70W or AASHTO M 270, Grade 70W steel.

10.48.2 Braced Non-Compact Sections

For sections of rolled or fabricated flexural members not meeting the requirements of Article 10.48.1.1 but meeting the requirement of Article 10.48.2.1 below, the design strength shall be computed as the lesser of

$$M_u = F_y S_{xt} \quad (10-98)$$

or

$$M_u = F_{cr} S_{xc} R_b \quad (10-99)$$

subject to the requirement of Article 10.48.2.1 (c) where

$$F_{cr} = \left(4,400 \frac{t}{b} \right)^2 \leq F_y$$

b = compression flange width (in.)

t = compression flange thickness (in.)

S_{xt} = elastic section modulus with respect to tension flange (in.³)

S_{xc} = elastic section modulus with respect to compression flange (in.³)

R_b = flange-stress reduction factor determined from the provisions of Article 10.48.4.1, with f_b substituted for the term M_r/S_{xc} when Equation (10-103b) applies

f_b = factored bending stress in the compression flange (psi), but not to exceed F_y

10.48.2.1 The above equations are applicable to sections meeting the following requirements:

(a) Compression flange:

$$\frac{b}{t} \leq 24 \quad (10-100)$$

(b) Web thickness:

The web thickness shall not exceed the requirement given by Equation (10-104) or Equation (10-109), as applicable, subject to the corresponding requirements as shown in Table 10.48.5A of Article 10.49.2 or 10.49.3. For unstiffened web, the web thickness shall not be less than $D/150$.

- (c) Spacing of lateral bracing for compression flange:

$$L_b \leq \frac{20,000,000 A_f}{F_y d} \quad (10-101)$$

where:

- + d = depth of beam or girder (in.)
 + A_f = flange area (in.²)

If Equation (10-101) is not satisfied, M_u calculated from Equation (10-99) shall not exceed M_u calculated from the provisions of Article 10.48.4.1

- (d) Maximum axial compression:

$$P \leq 0.15 F_y A \quad (10-102)$$

Members with axial loads in excess of $0.15 F_y A$ should be designed as beam-columns as specified in Article 10.54.2.

TABLE 10.48.2.1A Limitations for Braced Non-Compact Sections

F_y (psi)	36,000	50,000	70,000	90,000	100,000
b/t^*	23.2	19.7	16.6	14.7	13.9
$\frac{L_b d}{A_f}$	556	400	286	222	200
D/t_w	Refer to Articles 10.48.5.1, 10.48.6.1, 10.49.2 or 10.49.3, as applicable. For unstiffened webs, the limit is 150.				

* Limits shown are for $F_{cr} = F_y$. Refer also to article 10.48.2.1(a)

10.48.2.2 The limitations set forth in Article 10.48.2.1 above are given Table 10.48.2.1A .

10.48.3 Transitions

- + The design strength of sections with geometric properties falling between the limits of Articles 10.48.1 and 10.48.2 may be computed by straight-line interpolation, except that the web thickness must always satisfy Article 10.48.1.1(b).

10.48.4 Partially Braced Sections

Members not meeting the lateral bracing requirement of Article 10.48.2.1(c) shall be braced at discrete locations spaced at a distance, L_b , such that the design bending strength of the section under consideration satisfies the requirements of Article 10.48.4.1. Bracing shall be provided such that lateral deflection of the compression flange is restrained and the entire section is restrained against twisting.

10.48.4.1 If the lateral bracing requirement of Article 10.48.2.1(c) is not satisfied and the ratio of the moment of inertia of the compression flange to the moment of inertia of the member about the vertical axis of the web, I_{yc}/I_y , is within the limits of $0.1 \leq I_{yc}/I_y \leq 0.9$, the design bending strength for the limit state of lateral-torsional buckling shall be computed as:

$$M_u = M_r R_b \quad (10-103a)$$

$R_b = 1$ for longitudinally stiffened girders if the web slenderness satisfies the following requirement:

$$\frac{D}{t_w} \leq 5,460 \sqrt{\frac{k}{f_b}}$$

where:

$$\text{for } \frac{d_s}{D_c} \geq 0.4 \quad k = 5.17 \left(\frac{D}{d_s} \right)^2 \geq 9 \left(\frac{D}{D_c} \right)^2$$

for

$$\frac{d_s}{D_c} < 0.4 \quad k = 11.64 \left(\frac{D}{D_c - d_s} \right)^2$$

d_s = distance from the centerline of a plate longitudinal stiffener or the gage line of an angle longitudinal stiffener to the inner surface or the leg of the compression flange component (in.)

f_b = factored bending stress in compression flange (psi)

Otherwise, for girders with or without longitudinal stiffeners, R_b shall be calculated as

$$R_b = 1 - 0.002 \left(\frac{D_c t_w}{A_{fc}} \right) \left[\frac{D_c}{t_w} - \frac{I}{\sqrt{M_r S_{xc}}} \right] \leq 1.0 \quad (10-103b)$$

D_c = depth of web in compression (in.). For composite beams and girders, D_c shall be calculated in accordance with the provisions specified in Article 10.50(b).

t_w = thickness of web (in.)

A_{fc} = area of compression flange (in.²)

M_r = lateral torsional buckling moment defined below (lb.-in.)

S_{xc} = section modulus with respect to compression flange (in.³). Use S_{xc} for live load for a composite section

λ = 15,400 for all sections where D_c is less than or equal to $D/2$
 = 12,500 for sections where D_c is greater than $D/2$

For sections with $\frac{D_c}{t_w} \leq \frac{I}{\sqrt{F_y}}$ or with longitudinally stiffened webs:

$$M_r = 91 \times 10^6 C_b \left(\frac{I_{yc}}{L_b} \right) \sqrt{0.772 \frac{J}{I_{yc}} + 9.87 \left(\frac{d}{L_b} \right)^2} \leq M_y \quad (10-103c)$$

For sections with $\frac{I}{\sqrt{F_y}} < \frac{D_c}{t_w}$

for $L_b \leq L_p$

$$M_r = M_y \quad (10-103d)$$

$$L_p = \frac{9,500 r'}{\sqrt{F_y}} \quad (10-103d1)$$

for $L_r \geq L_b > L_p$

$$M_r = C_b F_y S_{xc} \left[1 - 0.5 \left(\frac{L_b - L_p}{L_r - L_p} \right) \right] \leq M_y \quad (10-103e)$$

$$L_r = \left(\frac{572 \times 10^6 I_{xc} d}{F_y S_{xc}} \right)^{1/2} \quad (10-103f)$$

for $L_b > L_r$

$$M_r = C_b \frac{F_y S_{xc}}{2} \left(\frac{L_r}{L_b} \right)^2 \leq M_y \quad (10-103g)$$

where:

L_b = unbraced length of the compression flange (in.)

L_p = limiting unbraced length for the yield moment capacity (in.)

L_r = limiting unbraced length for elastic lateral torsional buckling moment capacity (in.)

r' = radius of gyration of compression flange about the vertical axis in the plane of the web (in.)

I_{yc} = moment of inertia of compression flange about the vertical axis in the plane of the web (in.⁴)

d = depth of girder (in.)

$J = \frac{(b t^3)_c + (b t^3)_t + D t_w^3}{3}$ where b and t represent the flange width and the thickness of the compression and tension flange, respectively (in.⁴)

$$C_b = \frac{12.5 M_{\max}}{2.5 M_{\max} + 3 M_A + 4 M_B + 3 M_C}$$

where:

M_{\max} = absolute value of maximum moment in the unbraced beam segment (lb.-in.)

M_A = absolute value of moment at quarter point of the unbraced beam segment (lb.-in.)

- + M_B = absolute value of moment at midpoint of the unbraced beam segment (lb-in.)
- + M_c = absolute value of moment at three-quarter point of the unbraced segment (lb-in.)
- + C_b = 1.0 for unbraced cantilevers and for members where the moment within a significant portion of the unbraced segment is greater than or equal to the larger of the segment end moments.^a

The compression flange shall satisfy the requirement of Article 19.48.2.1(a). The web thickness shall not exceed the requirement given by Equation (10-104) or Equation (10-109), as applicable, subject to the corresponding requirements of Articles 10.49.2 or 10.49.3. For unstiffened web, the web thickness shall not be less than $D/150$.

10.48.4.2 Members with axial loads in excess of $0.15 F_y A$ should be designed as beam-columns as specified in Article 10.54.2.

10.48.5 Transversely Stiffened Girders

10.48.5.1 For girders not meeting the shear requirements of Article 10.48.8.1 (Equation 10-113) transverse stiffeners are required for the web. For girders with transverse stiffeners but without longitudinal stiffeners the width-thickness ratio (D/t_w) of the web shall not exceed the limiting values specified in Table 10.48.5A subject to the web thickness requirement of Article 10.49.2. If the web slenderness D/t_w exceeds the upper limit, either the section shall be modified to comply with the limit, or a longitudinal stiffener shall be provided.

10.48.5.2 The design bending strength of transversely stiffened girders meeting the requirements of Article 10.48.5.1 shall be computed by Articles 10.48.1, 10.48.2, 10.48.4.1, 10.50, 10.51, or 10.53, as applicable, subject to the requirements of Article 10.48.8.2.

TABLE 10.48.5A Limiting Width-Thickness Ratios for Web Plates and Stiffeners

Description of Component		Width-Thickness Ratio	Limiting Width-Thickness Ratio	F_y (psi)	Limiting Width-Thickness Ratios
Web Plates	With transverse stiffeners only	D/t_w	$\frac{36,500}{\sqrt{F_y}}$ (10-104)	36,000	192
				50,000	163
				70,000	138
				90,000	122
				100,000	115
	With transverse stiffeners and one longitudinal stiffener	D/t_w	$\frac{73,000}{\sqrt{F_y}}$ (10-109)	36,000	385
				50,000	326
				70,000	276
				90,000	243
				100,000	231
Stiffeners	Longitudinal stiffeners	b'/t_s	$\frac{2,600}{\sqrt{F_y}}$	(10-144)	
	Transverse stiffeners			16	(10-105)

b' = width of flange plate or width of outstanding element of web stiffeners (in.)

D = clear distance between flanges (in.)

F_y = specified minimum yield strength of the component under consideration (psi)

t_s = web stiffener outstanding element thickness (in.)

t_w = web plate thickness (in.)

+ ^a For the use of larger C_b values, see Structural Stability Research Council Guide to Stability Design Criteria for Metal Structures, 4th Ed., pg. 157.

10.48.5.3 The shear capacity of transversely stiffened girders shall be computed by Article 10.48.8. The width-to-thickness ratio (b'/t_s) of transverse stiffeners shall not exceed the limiting values specified in Table 10.48.5A.

The gross cross-sectional area of intermediate transverse stiffeners, A (in.²) shall meet the following requirement:

$$A \geq \left[0.15 B \frac{D}{t_w} (1 - C) \left(\frac{V}{V_u} \right) - 18 \right] \frac{F_{yweb}}{F_{cr}} t_w^2 \quad (10-106a)$$

where:

$$F_{cr} = \frac{9,025,000}{\left(\frac{b'}{t_s} \right)^2} \leq F_{ystiffener} \quad (10-106b)$$

b' = projecting width of the stiffener (in.)
 t_s = thickness of the stiffener (in.)
 F_{yweb} = specified minimum yield strength of the web (psi)
 $F_{ystiffener}$ = specified minimum yield strength of the stiffener (psi)
 B = 1.0 for stiffener pairs, 1.8 for single angles, and 2.4 for single plates;
 C = constant computed by Article 10.48.8.1.

When values computed by Equation (10-106a) approach zero or are negative, then transverse stiffeners need only meet the requirements of Equations (10-107), (10-105) and Article 10.34.4.10.

The moment of inertia of transverse stiffeners with reference to the plane defined below shall meet the following requirement:

$$I \geq d_o t_w^3 J \quad (10-107)$$

where:

$$J = 2.5 \left(\frac{D}{d_o} \right)^2 - 2 \geq 0.5 \quad (10-108)$$

d_o = distance between transverse stiffeners

When stiffeners are in pairs, the moment of inertia shall be taken about the centerline of the web plate. When single stiffeners are used, the moment of inertia shall be taken about the face in contact with the web plate.

Transverse intermediate stiffeners shall be preferably fitted tightly to the tension flange. If the intermediate stiffener is used for attaching a cross frame or diaphragm, a positive connection using either bolts or welds must be made to the tension flange. The distance between the end of the vertical weld on the stiffener to the web-to-flange weld shall be $4 t_w$ but not less than $1 \frac{1}{2}$ inches. Transverse stiffeners provided only on one side of the web must be welded to the compression flange and fitted tightly to the tension flange for the stiffener to be effective. Stiffener properties shall be as covered in Article 10.34.4.10.

10.48.6 Longitudinally Stiffened Girders

10.48.6.1 Longitudinal stiffeners shall be required on symmetrical girders when the web thickness is less than that specified by Article 10.48.5.1 and shall be placed at a distance $D/5$ from the inner surface of the compression flange.

The width-thickness ratio (D/t_w) of the web of plate girders with transverse stiffeners and one longitudinal stiffener shall not exceed the limiting values specified in Table 10.48.5A.

Singly symmetric girders are subject to the requirements of Article 10.49.3

10.48.6.2 The design bending strength of longitudinal stiffened girders meeting the requirements of Article 10.48.6.1 shall be computed by Articles 10.48.2, 10.48.4.1, 10.50.1.2, 10.50.2.2, 10.51, or 10.53 as applicable, subject to the requirements of Article 10.48.8.2.

10.48.6.3 The shear capacity of girders with one longitudinal stiffener shall be computed by Article 10.48.8.

The dimensions of the longitudinal stiffener shall be such that:

(a) the width-to-thickness ratio meets the requirement given in Table 10.48.5A. The factored bending stress in the longitudinal stiffener is not greater than the yield strength of the longitudinal stiffener.

(b) the moment of inertia of the stiffener meets the following requirement:

$$I \geq D t_w^3 \left[2.4 \left(\frac{d_o}{D} \right)^2 - 0.13 \right] \quad (10-110)$$

- + (c) the radius of gyration of the stiffener meets the
+ following requirement:

$$r \geq \frac{d_o \sqrt{F_y}}{23,000} \quad (10-111)$$

- In computing I and r values above, a centrally located web strip not more than $18t_w$ in width shall be considered as a part of the longitudinal stiffener. Transverse stiffeners for girder panels with longitudinal stiffeners shall be designed according to Article 10.48.5.3. In addition, the section modulus of the transverse stiffener shall meet the following requirement:

$$S_s \geq \frac{1}{3} \left(\frac{D}{d_o} \right) S_t \quad (10-112)$$

where:

- + D = total panel depth (clear distance between flange
+ components) (in.)
+ S_t = section modulus of the longitudinal stiffener.
+ (in³.)

10.48.7 Bearing Stiffeners

Bearing stiffeners shall be designed for beams and girders as specified in Articles 10.33.2 and 10.34.6.

- + Axial compression strength shall be computed as specified in Article 10.54.1. Bearing strength shall be taken at
+ $1.35 F_y$ times the bearing area of bearing stiffeners.

10.48.8 Shear

10.48.8.1 The shear capacity of webs of rolled or fabricated flexural members shall be computed as follows:

- + For unstiffened webs, the design shear strength shall
+ be limited to the plastic or buckling shear strength as
+ follows:

$$V_u = CV_p \quad (10-113)$$

For stiffened web panels complying with the provisions of Article 10.48.8.3, the shear capacity shall be determined by including post-buckling resistance due to tension-field action as follows:

$$V_u = V_p \left[C + \frac{0.87(1-C)}{\sqrt{1 + \left(\frac{d_o}{D} \right)^2}} \right] \quad (10-114)$$

V_p is equal to the plastic shear strength and is determined as follows:

$$V_p = 0.58 F_y D t_w \quad (10-115)$$

The constant C is equal to the buckling shear stress divided by the shear yield stress, and is determined as follows:

for $\frac{D}{t_w} < \frac{6,000\sqrt{k}}{\sqrt{F_y}}$

$$C = 1.0$$

for $\frac{6,000\sqrt{k}}{\sqrt{F_y}} \leq \frac{D}{t_w} \leq \frac{7,500\sqrt{k}}{\sqrt{F_y}}$

$$C = \frac{6,000\sqrt{k}}{\left(\frac{D}{t_w} \right) \sqrt{F_y}} \quad (10-116)$$

for $\frac{D}{t_w} > \frac{7,500\sqrt{k}}{\sqrt{F_y}}$

$$C = \frac{4.5 \times 10^7 k}{\left(\frac{D}{t_w} \right)^2 F_y} \quad (10-117)$$

where the buckling coefficient, $k = 5 + 5 / (d_o/D)^2$, except k shall be taken as 5 for unstiffened beams and girders.

- + D = clear, unsupported distance between flange components (in.)
- + d_o = distance between transverse stiffeners (in.)
- + F_y = specified minimum yield strength of the web plate (psi)

10.48.8.2 If a girder panel is controlled by Equation (10-114) and is subjected to the simultaneous action of shear and bending moment with the magnitude of the moment greater than $0.75 M_u$, the shear shall meet the following requirement:

$$\frac{V}{V_u} \leq 2.2 - \left(\frac{1.6M}{M_u} \right) \quad (10-118)$$

If a girder panel adjacent to a composite noncompact section is controlled by Equation (10-114) and is subjected to the simultaneous action of shear and bending moment with the magnitude of factored bending stress f_s greater than $0.75 F_{um}$, the shear shall meet the following requirement:

$$\frac{V}{V_u} \leq 2.2 - \left(\frac{1.6f_s}{F_{um}} \right) \quad (10-118a)$$

where:

- f_s = factored bending stress in either the top or bottom flange, whichever flange has the larger ratio of (f_s/F_{um})
- F_{um} = maximum bending strength of either the top or bottom flange, whichever flange has the larger ratio of (f_s/F_{um})

10.48.8.3 Where transverse intermediate stiffeners are required, transverse stiffeners shall be spaced at a distance, d_o , according to shear capacity as specified in Article 10.48.8.1, but not more than $3D$. Transverse stiffeners may be omitted in those portions of the girders where the maximum shear force is less than the value given by Article 10.48.8.1 Equation (10-113), subject to the handling requirements below.

- + Transverse stiffeners shall be required if D/t_w is greater than 150. The spacing of these stiffeners shall not exceed

the handling requirement $D \left[\frac{260}{D/t_w} \right]^2$.

For longitudinally stiffened girders, transverse stiffeners shall be spaced a distance, d_o , according to shear capacity as specified in Article 10.48.8.1, but not more than 1.5 times the web depth. The handling requirement given above shall not apply to longitudinally stiffened girders. The total web depth D shall be used in determining the shear capacity of longitudinally stiffened girders in Article 10.48.8.1 and in Equation (10-119).

The first stiffener space at the simple support end of a transversely or longitudinally stiffened girder shall be such that the shear force in the end panel will not exceed the plastic or buckling shear strength given by the following equation:

$$V_u = CV_p \quad (10-119)$$

For transversely stiffened girders, the maximum spacing of the first transverse stiffener is limited to $1.5D$.

10.49 FLEXURAL MEMBERS WITH SINGLY SYMMETRIC SECTIONS

10.49.1 General

For sections symmetric about the vertical axis but unsymmetric with respect to the horizontal centroidal axis, the provisions of Articles 10.48.1 through 10.48.4 shall be applicable.

10.49.2 Transversely Stiffened Sections

Girders with transverse stiffeners shall be designed and evaluated by the provisions of Article 10.48.5 except that when D_c , the clear distance between the neutral axis and the compression flange, exceeds $D/2$ the web thickness, t_w , shall meet the requirement:

$$\frac{D_c}{t_w} \leq \frac{18,250}{\sqrt{F_y}} \quad (10-120)$$

If the web slenderness D_c/t_w exceeds the upper limit, either the section shall be modified to comply with the limit, or a longitudinal stiffener shall be provided.

10.49.3 Longitudinally Stiffened Sections

10.49.3.1 Longitudinal stiffeners shall be required
 + on singly symmetric sections when the web thickness
 + does not meet the requirement specified by Articles
 + 10.48.5.1 or 10.49.2.

10.49.3.2 For girders with one longitudinal stiffener and transverse stiffeners, the provisions of Article 10.48.6 for symmetrical sections shall be applicable in addition to the following:

- (a) The optimum distance, d_s , of a plate longitudinal stiffener or the gage line of an angle longitudinal stiffener from the inner surface or the leg of the compression flange component is $D/5$ for a symmetrical girder. The optimum distance, d_s , for a singly symmetric composite girder in positive-moment regions may be determined from the equation given below:

$$\frac{d_s}{D_{cs}} = \frac{1}{1 + 1.5 \sqrt{\frac{f_{DL+LL}}{f_{DL}}}} \quad (10-121)$$

+ where:

- + D_{cs} = depth of the web in compression of the non-composite steel beam or girder (in.)
 + f_{DL} = non-composite dead-load stress in the compression flange (psi)
 + f_{DL+LL} = total non-composite and composite dead load plus the composite live-load stress in compression flange at the most highly stressed section of the web (psi)

The optimum distance d_s , of the stiffener in negative-moment regions of composite sections is $2D_c/5$, where D_c is the depth of the web in compression of the composite section at the most highly stressed section of the web.

- (b) When D_c exceeds $D/2$, the web thickness, t_w , shall meet the requirement:

$$\frac{D_c}{t_w} \leq \frac{36,500}{\sqrt{F_y}} \quad (10-122)$$

10.49.4 Braced Non-Compact Sections

Singly symmetric braced non-compact sections of rolled or fabricated flexural members shall be designed and evaluated by the provisions of Article 10.48.2.

10.49.5 Partially Braced Sections

The design strength of singly symmetric sections meeting all requirements of Article 10.48.2.1, except for the lateral bracing requirement given by Equation (10-101), shall be computed as the lesser of M_u calculated from Equation (10-98) or M_u calculated from Equation (10-99), with M_u calculated from Equation (10-99) not to exceed M_u calculated from the provisions of Article 10.48.4.1.

10.50 COMPOSITE SECTIONS

Composite sections shall be so proportioned that the following criteria are satisfied:

- (a) The design strength of any section shall not be less than the sum of the computed moments at that section multiplied by the appropriate load factors.
- (b) The web of the steel section shall be designed to carry the total external shear and must satisfy the applicable provisions of Articles 10.48 and 10.49. The value of D_c shall be taken as the clear distance between the neutral axis and the compression flange. In positive-moment regions, the value of D_c shall be calculated by summing the stresses due to the appropriate loadings acting on the respective cross sections supporting the loading. The depth of web in compression, D_c , in composite section subjected to negative bending may be taken as the depth of the web in compression of the composite section without summing the stresses from the various stages of loading. The web depth in compression, D_{cp} , of sections meeting the web compactness and ductility requirements of Article 10.50.1.1.2 under the maximum design loads shall be calculated from the full plastic section ignoring the sequence of load application. Girders with a web slenderness exceeding the limits of Article 10.48.5.1 or 10.49.2 shall either be modified to comply with these limits or else shall be stiffened by one longitudinal stiffener.

- (c) The moment capacity at first yield shall be computed considering the application of the dead and live loads to the steel and composite sections.
- (d) steel beam or girder shall satisfy the constructibility requirements of Article 10.61.
- (e) The stress in the top flange of a composite girder shall be limited to $0.6F_y$ under dead load if no calculations are made for the construction loading stage of the concrete deck. The concrete deck is assumed to be placed instantaneously.

10.50.1 Positive Moment Sections

10.50.1.1 Compact Sections

The design strength, M_u , of compact composite sections in positive-moment regions shall be computed in accordance with Article 10.50.1.1.2. The steel shall have the demonstrated ability to reach M_p . Steel such as AASHTO M 270 Grades 26, 50 and 50W (ASTM A 709 Grades 36, 50 and 50W), and ASTM A 709 Grade HPS 70W meet these requirements.

10.50.1.1.1 The resultant moment of the fully plastic stress distribution (Figure 10.50A) may be computed as follows:

- (a) The compressive force in the slab, C , is equal to the smallest of the values given by the following Equations:

$$(1) \quad C = 0.85 f'_c b t_s + (AF_y)_c \quad (10-123)$$

$$(2) \quad C = (AF_y)_{bf} + (AF_y)_{tf} + (AF_y)_w \quad (10-124)$$

where:

- b = effective width of slab specified in Article 38.3 (in.)
- t_s = the slab thickness (in.)
- $(AF_y)_c$ = product of the area and yield strength of that part of reinforcement which lies in the compression zone of the slab (lb.)
- $(AF_y)_{bf}$ = product of area and yield strength for bottom flange of steel section (including cover plate if any) (lb.)
- $(AF_y)_{tf}$ = product of area and yield strength for top flange of steel section (lb.)
- $(AF_y)_w$ = product of area and yield strength for web of steel section (lb.)

- (b) The depth of the stress block is computed from the compressive force in the slab.

$$a = \frac{C - (AF_y)_c}{0.85 f'_c b} \quad (10-125)$$

- (c) When the compressive force in the slab is less than the value given by Equation (10-124), the top portion of the steel section will be subjected to the following compressive force:

$$C' = \frac{\sum (AF_y) - C}{2} \quad (10-126)$$

where:

- (AF_y) = product of the area and yield strength of steel girder section (lb.)

- (d) The location of the neutral axis within the steel section measured from the top of the steel section may be determined as follows:

for $C' < (AF_y)_{tf}$

$$\bar{y} = \frac{C'}{(AF_y)_{tf}} t_{ff} \quad (10-127)$$

for $C' \geq (AF_y)_{tf}$

$$\bar{y} = t_{ff} + \frac{C' - (AF_y)_{tf}}{(AF_y)_w} D \quad (10-128)$$

- (e) The plastic moment capacity, M_p , of the section in bending is the first moment of all forces about the neutral axis, taking all forces and moment arms as positive quantities.

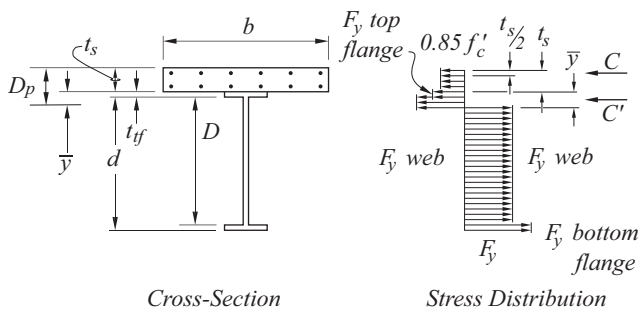
FIGURE 10.50A Plastic Stress Distribution

10.50.1.1.2 Composite sections of constant-depth members in positive-moment regions without longitudinal web stiffeners and without holes in the tension flange shall qualify as compact when the web of the steel section satisfies the following requirement:

$$\frac{2D_{cp}}{t_w} \leq \frac{19,230}{\sqrt{F_y}} \quad (10-129)$$

where:

- + D_{cp} = depth of the web in compression at the plastic moment calculated in accordance with Article 10.50.1.1.1 (in.)
- + t_w = web thickness (in.)

Equation (10-129) is satisfied if the neutral axis at the plastic moment is located above the web; Otherwise D_{cp} shall be computed as \bar{y} from Equation (10-128) minus

Also, the distance from the top of slab to the neutral axis at the plastic moment, D_p , shall satisfy:

$$\left(\frac{D_p}{D'} \right) \leq 5 \quad (10-129a)$$

where:

$$D' = \beta \frac{(d + t_s + t_h)}{7.5}$$

$$\beta = 0.9 \text{ for } F_y = 36,000 \text{ psi}$$

$$= 0.7 \text{ for } F_y = 50,000 \text{ psi and } 70,000 \text{ psi}$$

- + d = depth of the steel beam or girder (in.)
- + t_s = thickness of the slab (in.)

t_h = thickness of the concrete haunch above the beam or girder top flange (in.)

Equation (10-129a) need not be checked for sections where the maximum flange stress does not exceed the specified minimum flange yield strength.

The design bending strength, M_u of compact composite sections in simple spans or in the positive-moment regions of continuous spans with compact non-composite or composite negative-moment pier sections shall be taken as:

for $D_p \leq D'$

$$M_u = M_p \quad (10-129b)$$

for $D' < D_p \leq 5D'$

$$M_u = \frac{5M_p - 0.85M_y}{4} + \frac{0.85M_y - M_p}{4} \left(\frac{D_p}{D'} \right) \quad (10-129c)$$

where:

M_p = plastic moment capacity of the composite positive moment section calculated in accordance with Article 10.50.1.1.1 (lb-in.)

M_y = moment capacity at first yield of the composite moment section calculated as F_y times the section modulus with respect to the tension flange (lb-in.). The modular ratio, n , shall be used to compute the transformed section properties.

In continuous spans with compact composite positive-moment sections, but with noncompact noncomposite or composite negative-moment pier sections, the maximum bending strength, M_u , of the composite positive-moment sections shall be taken as either the moment capacity at the first yield determined as specified in Article 10.50(c), or as:

$$M_u = M_y + A(M_u - M_s)_{pier} \quad (10-129d)$$

where:

- M_y = the moment at first yield of the compact positive moment section calculated in accordance with Article 10.50(c) (lb-in.)
 +
 $(M_u - M_s)_{pier}$ = moment capacity of noncompact section at the pier, M_u , given by Article 10.48.2 or Article 10.48.4, minus the elastic moment at the pier, M_s , for the loading producing maximum positive bending in the span. Use the smaller value of the difference for the two pier sections for interior spans (lb-in.)
 +
 A = 1 for interior spans
 = distance from end support to the location of maximum positive moment divided by the span length for end spans.

M_u computed from Equation (10-129d) shall not exceed the applicable value of M_u computed from either Equation (10-129b) or Equation (10-129c).

For continuous spans where the maximum bending strength of the positive-moment sections is determined from Equation (10-129d), the maximum positive moment in the span shall not exceed M_y , for the loading which produces the maximum negative moment at the adjacent pier(s).

For composite sections in positive-moment regions not satisfying the requirements of Equation (10-129) or Equation (10-129a), or of variable-depth members or with longitudinal web stiffeners, or with holes in the tension flange, the design bending strength shall be determined as specified in Article 10.50.1.2.

10.50.1.2 Non-Compact Sections

10.50.1.2.1 When the steel section does not satisfy the compactness requirements of Article 10.50.1.1.2, the sum of bending stresses due to the appropriate loadings acting on the respective cross sections supporting the loadings shall not exceed F_y for the tension flange, and $F_y R_b$ for compression flange, where R_b is the flange-stress reduction factor determined from the provisions of Article 10.48.4.1. When R_b is determined from Equation (10-103b), f_b shall be substituted for the term M_r/S_{xc} and A_{fc} shall be taken as the effective combined transformed area of the top flange and concrete deck that yields D_c calculated in accordance with Article 10.50(b). f_b is equal to the factored bending stress in the compression flange (psi), but not to exceed F_y . The resulting R_b factor shall be distributed to the top flange and

concrete deck in proportion to their relative stiffness. The provisions of Article 10.48.2.1(b) shall apply.

10.50.1.2.2 When the girders are not provided with temporary supports during the placing of dead loads, the sum of the stresses produced by $1.30M_{SD}$ acting on the steel girder alone with $1.30M_{CD}$ and the appropriate factored live loading according to Table 3.22.1A acting on the composite girder shall not exceed yield strength at any point, where M_{SD} and M_{CD} are the moments caused by the dead load acting on the steel girder and composite girder, respectively.

10.50.1.2.3 When the girders are provided with effective intermediate supports that are kept in place until the concrete has attained 75 percent of its required 28-day strength, stresses produced by the factored dead load plus live loading, acting on the composite girder, shall not exceed yield strength at any point.

10.50.2 Negative Moment Sections

The design strength of composite sections in negative moment regions shall be computed in accordance with Articles 10.50.2.1 or 10.50.2.2, as applicable. It shall be assumed that the concrete slab does not carry tensile forces. In cases where the slab reinforcement is continuous over interior supports, the reinforcement may be considered to act compositely with the steel section.

10.50.2.1 Compact Sections

Composite sections of constant-depth members without longitudinal web stiffeners and without holes in the tension flange in negative bending qualify as compact when their steel section meets the requirements of Article 10.48.1.1, and has the demonstrated ability to reach M_p . Steels such as AASHTO M 270 Grade 26, 50 and 50W (ASTM A 709, Grade 36, 50 and 50W), and ASTM A 709 Grade HPS 70W meet these requirements. M_u shall be computed as the resultant moment of the fully plastic stress distribution acting on the section including any composite slab reinforcement.

If the distance from the neutral axis to the compression flange exceeds $D/2$, the compact section requirements given by Equation (10-94) and (10-95) must be modified by replacing D with the quantity $2D_{cp}$, where D_{cp} is the depth of the web in compression at the plastic moment.

10.50.2.2 Non-Compact Sections

When the steel section does not satisfy the compactness requirements of Article 10.50.2.1, but does satisfy the requirement of Article 10.48.2.1, the sum of bending stresses due to the appropriate loadings acting on the respective cross sections supporting the loadings shall not exceed F_y for the tension flange, and $F_{cr}R_b$ for compression flange, where F_{cr} is the critical compression flange stress specified in Article 10.48.2 and R_b is the flange-stress reduction factor determined from the provisions of Article 10.48.4.1. When R_b is determined from Equation (10-103b), f_b shall be substituted for the term M_r/S_{xc} . f_b is equal to the factored bending stress in the compression flange (psi), but not to exceed F_y . When all requirements of Article 10.48.2.1 are satisfied, except for lateral bracing requirement given by Equation (10-101), the design strength of the compression flange shall be taken to be $F_{cr}R_b$ but not to exceed M_u/S_{xc} , where M_u and S_{xc} are determined according to the provisions of Article 10.48.4.1.

10.50.2.3 The minimum longitudinal reinforcement including the longitudinal distribution reinforcement must equal or exceed 1 percent of the cross-sectional area of the concrete slab whenever the longitudinal tensile stress in the concrete slab due to either the factored construction loads or the overload specified in Article 10.57 exceeds $0.9f_r$, where f_r is the modulus of rupture specified in Article 8.15.2.1.1. The area of concrete slab shall be taken equal to the structural thickness times the entire width of the bridge deck. The required reinforcement shall be No. 6 bars or smaller spaced at not more than 12 inches. Two-thirds of this required reinforcement is to be placed in the top layer of the slab. Placement of distribution steel as specified in Article 3.24.10 is waived.

10.50.2.4 When shear connectors are omitted from the negative moment region, the longitudinal reinforcement shall be extended into the positive moment region beyond the anchorage connectors at least 40 times the reinforcement diameter.

10.51 COMPOSITE BOX GIRDERS*

This section pertains to the design of simple and continuous bridges of moderate length supported by two or more single-cell composite box girders. The distance

* For information regarding the design of long-span steel box girder bridge, Report No. FHWA-TS-80-205, "Proposed Design Specifications for Steel Box Girder Bridges" is available from the Federal Highway Administration.

center-to-center of the flanges of adjacent boxes shall be not greater than 1.2 times and not less than 0.8 times the distance center-to-center of the flanges of each box. In addition to the above, when nonparallel girders are used the distance center-to-center of adjacent flanges at supports shall be not greater than 1.35 times and not less than 0.65 times the distance center-to-center of the flanges of each box. The cantilever overhang of the deck slab, including curbs and parapet, shall be limited to 60 percent of the distance between the centers of adjacent top steel flanges of adjacent box girders, but in no case greater than 6 feet.

10.51.1 Design Bending Strength

The design bending strength of box girders shall be determined according to the applicable provisions of Articles 10.48, 10.49, and 10.50. In addition, the design strength of the negative moment sections shall be limited by:

$$M_u = F_{cr}S \quad (10-130)$$

where:

F_{cr} = critical stress of the bottom flange plate as given in Article 10.51.5 (psi)

10.51.2 Live Load Moment Distribution

The live load bending moment for each box girder shall be determined in accordance with Article 10.39.2.

10.51.3 Web Plates

The design shear V_w for a web shall be calculated using the following equation:

$$V_w = \frac{V}{\cos\theta} \quad (10-131)$$

where:

V = one-half of the total vertical shear force on one box girder (lb.)

θ = angle of inclination of the web plate to the vertical

The inclination of the web plates to the vertical shall not exceed 1 to 4.

10.51.4 Tension Flanges

In the case of simply supported spans, the bottom flange shall be considered fully effective in resisting bending if its width does not exceed one-fifth the span length. If the flange plate width exceeds one-fifth of the span, only an amount equal to one-fifth of the span shall be considered effective.

For continuous spans, the requirements above shall be applied to the distance between points of contraflexure.

10.51.5 Compression Flanges

+ **10.51.5.1** For unstiffened compression flanges, the
+ critical stress, F_{cr} , shall be computed as:

+ for
$$\frac{b}{t} \leq \frac{6,140}{\sqrt{F_y}} \quad (10-132)$$

+
$$F_{cr} = F_y \quad (10-132a)$$

+ for
$$\frac{6,140}{\sqrt{F_y}} < \frac{b}{t} \leq \frac{13,300}{\sqrt{F_y}} \quad (10-133)$$

+
$$F_{cr} = 0.592 F_y \left(1 + 0.687 \sin \frac{c\pi}{2} \right) \quad (10-134)$$

+
$$c = \frac{13,300 - \frac{b}{t} \sqrt{F_y}}{7,160} \quad (10-135)$$

+ for
$$\frac{b}{t} > \frac{13,300}{\sqrt{F_y}} \quad (10-136)$$

+
$$F_{cr} = 105 \left(\frac{t}{b} \right)^2 \times 10^6 \quad (10-137)$$

+ where:

b = flange width between webs (in.) +
 t = flange thickness (in.) +

10.51.5.2 Deleted +

10.51.5.3 Deleted +

10.51.5.4 If longitudinal stiffeners are used, they shall be equally spaced across the flange width and shall be proportioned so that the moment of inertia of each stiffener about an axis parallel to the flange and at the base of the stiffener meet the following requirement: +

$$I_s \geq \phi t^3 w \quad (10-138)$$

where:

$\phi = 0.07 k^3 n^4$ when n equals 2, 3, 4, or 5;

$\phi = 0.125 k^3$ when n equals 1;

w = width of flange between longitudinal stiffeners or distance from a web to the nearest longitudinal stiffener (in.) +

n = number of longitudinal stiffeners;

k = buckling coefficient which shall not exceed 4.

10.51.5.4.1 For longitudinally stiffened flanges, the critical stress, F_{cr} , shall be computed as: +

for
$$\frac{w}{t} \leq \frac{3,070 \sqrt{k}}{\sqrt{F_y}} \quad (10-139) +$$

$$F_{cr} = F_y \quad (10-139a) +$$

for
$$\frac{3,070 \sqrt{k}}{\sqrt{F_y}} < \frac{w}{t} \leq \frac{6,650 \sqrt{k}}{\sqrt{F_y}} \quad (10-140) +$$

$$F_{cr} = 0.592 F_y \left(1 + 0.687 \sin \frac{c\pi}{2} \right) \quad (10-141) +$$

$$c = \frac{6,650 \sqrt{k} - \frac{w}{t} \sqrt{F_y}}{3,580} \quad (10-141a) +$$

+ for
$$\frac{b}{t} > \frac{6,650\sqrt{k}}{\sqrt{F_y}} \quad (10-142)$$

+
$$F_{cr} = 26.2k \left(\frac{t}{w} \right)^2 \times 10^6 \quad (10-143)$$

+ 10.51.5.4.2 Deleted

+ 10.51.5.4.3 Deleted

10.51.5.4.4 When longitudinal stiffeners are used, it is preferable to have at least one transverse stiffener placed near the point of dead load contraflexure. The stiffener should have a size equal to that of a longitudinal stiffener. The number of longitudinal stiffeners preferably shall not exceed 2. If the number of longitudinal stiffeners exceeds 2, then the use of additional transverse stiffeners shall be considered.

+ 10.51.5.5 The width-to-thickness ratio of any outstanding element of the flange stiffeners shall not exceed the limiting values specified in Table 10.48.5A.

10.51.5.6 Compression flanges shall also satisfy the provisions of Article 10.51.4. The effective flange plate width shall be used to calculate the factored flange bending stress. The full flange plate width shall be used to calculate the buckling stress of the flange.

10.51.6 Diaphragms

Diaphragms, cross-frames, or other means shall be provided within the box girders at each support to resist transverse rotation, displacement, and distortion.

Intermediate diaphragms or cross-frames are not required for box girder bridges designed in accordance with this specification.

+ **10.51.7 Flange to Web Welds**

The total effective thickness of the web-flange welds shall not be less than the thickness of the web, except, when two or more interior intermediate diaphragms per span are provided, the minimum size fillet welds specified in Article 10.23.2.2 may be used. Regardless of the type weld used, welds shall be deposited on both sides of the connecting flange or web plate.

10.52 SHEAR CONNECTORS

10.52.1 General

The horizontal shear at the interface between the concrete slab and the steel girder shall be provided for by mechanical shear connectors throughout the simple spans and the positive moment regions of continuous spans. In the negative moment regions, shear connectors shall be provided when the reinforcing steel embedded in the concrete is considered a part of the composite section. In case the reinforcing steel embedded in the concrete is not considered in computing section properties of negative moment sections, shear connectors need not be provided in these portions of the span, but additional connectors shall be placed in the region of the points of dead load contraflexure as specified in Article 10.38.5.1.3.

10.52.2 Number of Connectors

The number of shear connectors shall be determined in accordance with Article 10.38.5.1.2 and checked for fatigue in accordance with Articles 10.38.5.1.1 and 10.38.5.1.3.

10.52.3 Maximum Spacing

The maximum pitch shall not exceed 24 inches except over the interior supports of continuous beams where wider spacing may be used to avoid placing connectors at locations of high stresses in the tension flange.

10.53 HYBRID GIRDERS

This section pertains to the design of girders that utilize a lower strength steel in the web than in one or both of the flanges. It applies to composite and non-composite plate girders and to composite box girders. At any cross section where the bending stress in either flange caused by the maximum design load exceeds the minimum specified yield strength of the web steel, the compression-flange area shall not be less than the tension-flange area. The top-flange area shall include the transformed area of any portion of the slab or reinforcing steel that is considered to act compositely with the steel girder.

The provisions of Article 10.48 through 10.52 shall apply to hybrid beams and girders except as modified below. In all equations of these articles, F_y shall be taken as the minimum specified yield strength of the steel of the element under consideration with the following exceptions:

- (1) In Articles 10.48.1.1(b), 10.48.4.1, 10.48.5.1, 10.48.6.1, 10.49.2, 10.49.3.2(b), and 10.50.1.1.2, use F_y of the compression flange.
- (2) Articles 10.57.1 and 10.57.2 shall apply to the flanges, but not to the web of hybrid girders.

The provisions specified in Article 10.40.4 shall also apply. Longitudinal web stiffeners preferably shall not be located in yielded portion of the web.

+ 10.53.1 Non-Composite Sections

10.53.1.1 Compact Sections

The equation of Article 10.48.1 for the maximum strength of compact sections shall be replaced by the expression:

$$M_u = F_{yf}Z \quad (10-145)$$

where:

- + F_{yf} = specified minimum yield strength of the flange
+ (psi)
+ Z = plastic section modulus (in.³)

+ In computing Z , the web thickness shall be multiplied
+ by the ratio of the specified minimum yield strength of the
+ web, F_{yw} , to the specified minimum yield strength of the
+ flange F_{yf} .

10.53.1.2 Braced Non-Compact Sections

+ The equations of Article 10.48.2 for the design bending
+ strength of braced non-compact sections shall be
+ replaced by the expressions

$$M_u = F_{yf}S_{xt}R \quad (10-146)$$

$$M_u = F_{cr}S_{xc}R_bR \quad (10-146a)$$

+ where:

S_{xt} = section modulus with respect to the tension
flange (in.³)

For symmetrical sections,

$$R = \frac{12 + \beta(3\alpha - \alpha^3)}{12 + 2\beta} \quad (10-147)$$

where:

$$\alpha = \frac{F_{yw}}{F_{yf}}$$

$$\beta = \frac{A_w}{A_f}$$

for unsymmetrical sections,

$$R = 1 - \frac{\beta\psi(1-\alpha)^2(3-\psi+\alpha\psi)}{6 + \beta\psi(3-\psi)} \quad (10-148)$$

where:

ψ = distance from the outer fiber of the tension
flange to the neutral axis divided by depth of the
steel section

R shall be taken 1.0 at sections where the bending
stress in both flanges caused by factored loads does not
exceed the specified minimum yield strength of the web.

10.53.1.3 Partially Braced Sections

The design bending strength of non-compact hybrid
sections of partially braced members not satisfying the
lateral bracing requirement given by Equation (10-101)
shall be calculated as the lesser of the M_u calculated from
Equation (10-146) or M_u calculated from Equation (10-
146a). M_u calculated from Equation (10-146a) is not to
exceed M_u calculated from the provisions of Article
10.48.4.1 with Equation (10-103a) replaced by the ex-
pression

$$M_u = M_r R_b R \quad (10-148a)$$

and the yield moment calculated as

$$M_y = F_{yf} S R \quad (10-148b)$$

where:

- + R = Reduction factor for hybrid girders determined from Article 10.53.1.2
- + R_b = bending reduction factor determined by Equation (10-103)

10.53.1.4 Transversely Stiffened Girders

Equation (10-114) of Article 10.48.8.1 for the shear capacity of transversely stiffened girders shall be replaced by the expression

$$V_u = V_p C \quad (10-149)$$

The provisions of Article 10.48.8.2 and equation for A in Article 10.48.5.3 are not applicable to hybrid girders.

+ 10.53.2 Composite Sections

+ The design strength of a compact composite section shall be computed as specified in Article 10.50.1.1.2 or Article 10.50.2.1, as applicable, using the specified minimum yield strength of the element under consideration to compute the plastic moment capacity. The yield moment in Article 10.50.1.1.2 shall be multiplied by R (for singly symmetrical sections) from Article 10.53.1.2, where ψ is calculated as specified below for non-compact composite sections.

+ The design bending strength of a non-compact composite section shall be taken as the design strength computed from Article 10.50.1.2 or Article 10.50.2.2, as applicable times R (for unsymmetrical sections) from Article 10.53.1.2, in which ψ is the distance from the outer fiber of the tension flange to the neutral axis of the transformed section divided by the depth of the steel section.

10.54 COMPRESSION MEMBERS

10.54.1 Axial Loading

+ 10.54.1.1 Design Axial Strength

+ The design axial compression strength of concentrically loaded columns shall be computed as:

$$P_u = 0.85 A_g F_{cr} \quad (10-150)$$

where:

- + A_g = gross effective area of the column cross section (in.²)
- + F_{cr} = critical stress determined by one of the following two formulas* (psi)

for
$$\frac{KL_c}{r} \leq \sqrt{\frac{2\pi^2 E}{F_y}} \quad (10-151) \quad +$$

$$F_{cr} = F_y \left[1 - \frac{F_y}{4\pi^2 E} \left(\frac{KL_c}{r} \right)^2 \right] \quad (10-152) \quad +$$

for
$$\frac{KL_c}{r} > \sqrt{\frac{2\pi^2 E}{F_y}} \quad (10-153) \quad +$$

$$F_{cr} = \frac{\pi^2 E}{\left(\frac{KL_c}{r} \right)^2} \quad (10-154) \quad +$$

where:

- + K = effective length factor in the plane of buckling;
- + L_c = length of the member between points of support (in.)
- + r = radius of gyration in the plane of buckling (in.)
- + F_y = yield stress of the steel (psi)
- + E = 29,000,000 (psi)

*Singly symmetric and unsymmetric compression members, such as angles, or tees, and doubly symmetric compression members, such as cruciform or built-up members with very thin walls, may also require consideration of flexural-torsional and torsional buckling. Refer to the *Manual of Steel Construction*, Ninth Edition, 1989, American Institute of Steel Construction.

10.54.1.2 Effective Length

The effective length factor K shall be determined as follows:

- (a) For members having lateral support in both directions at its end:

$K = 0.75$ for riveted, bolted, or welded end connections;

$K = 0.875$ for pinned ends.

- (b) For members having ends not fully supported laterally by diagonal bracing or an attachment to an adjacent structure, the effective length factor shall be determined by a rational procedure.*

10.54.2 Combined Axial Load and Bending

The combined maximum axial force P and the maximum bending moment M acting on a beam-column shall satisfy the following equations:

$$+ \frac{P}{0.85A_sF_{cr}} + \frac{M_x C_{mx}}{M_{ux} \left(1 - \frac{P}{A_s F_{ex}}\right)} + \frac{M_y C_{my}}{M_{uy} \left(1 - \frac{P}{A_s F_{ey}}\right)} \leq 1.0 \quad (10-155)$$

$$+ \frac{P}{0.85A_sF_y} + \frac{M_x}{M_{px}} + \frac{M_y}{M_{py}} \leq 1.0 \quad (10-156)$$

where:

F_{cr} = critical stress as determined by the equations of Article 10.54.1.1 (psi)

M_u = design bending strength as determined by Articles 10.48.1, 10.48.2, or 10.48.4;

$$+ F_e = \frac{E\pi^2}{\left(\frac{KL_c}{r}\right)^2} \text{ the Euler buckling stress in the plane of bending;} \quad (10-157)$$

C_{mx}, C_{my} = coefficients applied to bending terms in interaction formula for prismatic members; dependent upon member curvature caused by applied moments about the x-axis and y-axis, respectively, as determined from Table 10.36A

M_p = $F_y Z$, the full plastic moment of the section (lb-in.)

Z = plastic section modulus (in.³)

$\frac{KL_c}{r}$ = effective slenderness ratio in the plane of bending;

x = subscript; represents the x axis

y = subscript; represents the y axis

10.54.2.1 Deleted

10.54.2.2 Deleted

10.55 SOLID RIB ARCHES

10.55.1 Moment Amplification and Allowable Stresses

$$A_f = \frac{1}{1 - \frac{1.18T}{AF_e}} \quad (10-159)$$

$$F_a = \frac{F_y}{1.18} \left[1 - \frac{\left(\frac{KL}{r}\right)^2 F_y}{4\pi^2 E} \right] \text{ and } F_b = F_y \quad (10-160)$$

10.55.2 Web Plates

10.55.2.1 The width-thickness ratio (D/t_w) of the web plates shall not exceed the limiting values specified in Table 10.55.2A.

* B.G. Johnson, *Guide to Stability Design Criteria for Metal Structures*, John Wiley and Sons, Inc., New York, 1976.

TABLE 10.55.2A Limiting Width-Thickness Ratios for Solid Rib Arches

Description of Component		Width-Thickness ratio	Limiting Width-Thickness Ratio
Web Plates	Without longitudinal stiffeners	D/t_w	$\frac{6,750}{\sqrt{f_a}}$ (10-161)
	With two longitudinal stiffeners at the one-third points of the web depth		$\frac{10,150}{\sqrt{f_a}}$ (10-162)
			$\frac{13,500}{\sqrt{f_a}}$ (10-163)
	Outstanding element of stiffeners	b'/t_s	$\frac{2,200}{\sqrt{f_a + f_b/3}} \leq 12$ (10-164)
Flange Plates	Plates between webs	b'/t_f	$\frac{5,700}{\sqrt{f_a + f_b}}$ (10-165)
	Overhang plates		$\frac{2,200}{\sqrt{f_a + f_b}} \leq 12$ (10-166)

b' = width of flange plate or width of outstanding element of web stiffeners (in.)

D = clear distance between flanges (in.)

f_a = calculated axial compressive stress in the component under consideration (psi)

f_b = calculated compressive bending stress in the component under consideration (psi)

t_f = flange plate thickness (in.)

t_s = web stiffener outstanding element thickness (in.)

t_w = web plate thickness (in.)



+ **10.55.2.2** The width-thickness ratio (b'/t_s) of any
 + outstanding element of the web stiffeners shall not ex-
 + ceed the limiting values specified in Table 10.55.2.A.

10.55.3 Flange Plates

+ The width-thickness ratio (b'/t_f) of flange plates shall not
 + exceed the limiting values specified in Table 10.55.2.A.

10.56 SPLICES, CONNECTIONS, AND DETAILS

10.56.1 Connectors

10.56.1.1 General

+ Connectors and connections shall be proportioned so
 + that their design strength as given in this Article, as
 + applicable, shall be at least equal to the effects of service
 + loads multiplied by their respective load factors as speci-
 + fied in Article 3.22.

10.56.1.2 Welds

+ The design strength of the weld metal in groove and fillet
 + welds shall be equal to or greater than that of the base metal,
 + except that the designer may use electrode classifications
 + with strengths less than the base metal when detailing fillet
 + welds for quenched and tempered steels. However, the
 + welding procedure and weld metal shall be selected to
 + ensure sound welds. The effective weld area shall be taken
 + as defined in ANSI/AASHTO/AWS D1.5 Bridge Welding
 + Code, Article 2.3 and the Standard Specifications of the
 + California Department of Transportation.

+ The design strength of the weld metal, F (psi), shall be
 + taken as:

+ Groove Welds:

+
$$F = 1.00 F_y \quad (10-166a)$$

+ Fillet Welds:

+
$$F = 0.45 F_u \quad (10-166b)$$

+ where:

F_y = specified minimum yield strength of +
 connected material (psi) +
 F_u = specified minimum tensile strength of the weld- +
 ing rod but not greater than the tensile stress of +
 the connected parts (psi) +

10.56.1.3 Fasteners

10.56.1.3.1 In proportioning fasteners (rivets, bolts, +
 threaded studs and threaded rods), the cross sectional +
 area based upon nominal diameter shall be used.

10.56.1.3.2 Design Shear Strength

The design shear strength of a fastener, R_v (lb.), shall +
 be taken as: +

For fasteners in joints whose length between extreme +
 fasteners measured parallel to the line of action of the +
 force is less than 50 inches:

$$R_v = A_b F_v N_s \quad (10-166c)$$

where:

A_b = area of the fastener corresponding to the nomi- +
 nal diameter (in.²) +
 F_v = design shear strength of fastener material speci- +
 fied in Table 10.56A (psi) +
 N_s = number of shear planes of the fastener +

The design shear strength of a fastener in connections +
 greater than 50 inches shall be taken as 0.8 times the value +
 given by Equation (10-166c).

10.56.1.3.3 Design Tension Strength

The design tension strength of a fastener, R_t (lb.), shall +
 be taken as: +

$$R_t = A_b F_t \quad (10-166d)$$

where:

F_t = design tension strength of fastener material speci- +
 fied in Table 10.56A (psi) +

TABLE 10.56A Design Strength of and Fastener Materials

Type of Fasteners	Design Shear Strength $F_v = \phi F_{nv}$ (psi)		Design Tension Strength $F_t = \phi F_{nt}$ (psi)	
	ϕ	F_{nv} (psi)	ϕ	F_{nt} (psi)
Rivets	0.65	$0.58F_u$	0.65	F_u
Bolts Threads are excluded from shear plane	0.78	$0.48F_u$	0.65 (for A307, A36, A588, A572) 0.75 (for others)	$0.75F_u$
Bolts Threads are included in shear plane		$0.38F_u$		

F_u = specified minimum tensile strength of the fastener given in Table 10.2C (psi)

10.56.1.3.4 The design bearing strength, R (lb.), on the connected material in standard, oversized, short-slotted holes loaded in any direction, or long-slotted holes parallel to the applied bearing force shall be taken as:

$$R = 0.9L_c t F_u \leq 1.8d t F_u \quad (10-166e)$$

The design bearing strength, R (lb.), on the connected material in long-slotted holes perpendicular to the applied bearing force shall be taken as:

$$R = 0.75L_c t F_u \leq 1.5d t F_u \quad (10-166f)$$

The design bearing strength for the connection is equal to the sum of the design bearing force strength for the individual bolts in the connection.

where:

- R = design bearing strength (lb.)
- F_u = specified minimum tensile strength of the connected part (psi)
- L_c = clear distance between the holes or between the hole and the edge of the material in the direction of the applied bearing force (in.)
- d = nominal diameter of bolt (in.)
- t = thickness of connected material (in.)

10.56.1.3.5 High-strength bolts preferably shall be used for fasteners subject tension or combined shear and tension.

For combined tension and shear, bolts and rivets shall be proportioned so that the tensile stress does not exceed:

for $f_v / F_v \leq 0.33$

$$F'_t = F_t \quad (10-167)$$

for

$$F'_t = F_t \sqrt{1 - (f_v / F_v)^2} \quad (10-167a)$$

where:

- f_v = calculated rivet or bolt stress in shear (psi)
- F_v = design shear strength of rivet or bolt from Table 10.56A or equal to $K_h \mu T_b$ as specified in Article 10.57.3.1 (psi)
- F_t = design tensile strength of rivet or bolt from Table 10.56A (psi)
- F'_t = reduced design tensile strength of rivet or bolt due to the applied shear stress (psi)

10.56.1.4 Slip-Critical Joints

Slip-critical joints shall be designed to prevent slip at the overload in accordance with Article 10.57.3, but as a minimum the bolts shall be capable of developing the minimum strength requirements in bearing of Articles 10.18 and 10.19.

Potential slip of joints should be investigated at intermediate load stages especially those joints located in composite regions.

10.56.2 Bolts Subjected to Prying Action by Connected Parts

+ Bolts required to carry applied load by means of direct tension shall be proportioned for the sum of the external load and tension resulting from prying action produced by deformation of the connected parts. The total tension should not exceed the values given in Table 10.56A.

The tension due to prying actions shall be computed as:

$$Q = \left[\frac{3b}{8a} - \frac{t^3}{20} \right] T \quad (10-168)$$

where:

- + Q = prying tension per bolt (taken as zero when negative) (lb.)
- + T = direct tension per bolt due to external load (lb.)
- + a = distance from center of bolt under consideration to edge of plate (in.)
- + b = distance from center of bolt under consideration to toe of fillet of connected part (in.)
- + t = thickness of thinnest part connected (in.)

10.56.3 Rigid Connections

10.56.3.1 All rigid frame connections, the rigidity of which is essential to the continuity assumed as the basis of design, shall be capable of resisting the moments, shears, and axial loads to which they are subjected by maximum loads.

+ **10.56.3.2** The thickness of beam web shall meet the following requirement:

$$t_w \geq \sqrt{3} \left(\frac{M_c}{F_y d_b d_c} \right) \quad (10-169)$$

where:

- M_c = column moment (lb-in.) +
- d_b = beam depth (in.) +
- d_c = column depth (in.) +

When the thickness of the connection web does not satisfy the above requirement, the web shall be strengthened by diagonal stiffeners or by a reinforcing plate in contact with the web over the connection area. +

At joints where the flanges of one member are rigidly framed into one flange of another member, the thickness of the web, t_w , supporting the latter flange and the thickness of the latter flange, t_c , shall be checked by the formulas below. Stiffeners are required on the web of the second member opposite the compression flange of the first member when

$$t_w < \frac{A_f}{t_b + 5k} \quad (10-170)$$

and opposite the tension flange of the first member when

$$t_c < 0.4 \sqrt{A_f} \quad (10-171)$$

where:

- t_w = thickness of web to be stiffened (in.) +
- k = distance from outer face of flange to toe of web fillet of member to be stiffened (in.) +
- t_b = thickness of flange delivering concentrated force (in.) +
- t_c = thickness of flange of member to be stiffened (in.) +
- A_f = area of flange delivering concentrated load (in.²) +

10.57 OVERLOAD

The overload is defined as Group 1 loading divided by 1.3. If moment distribution is permitted under the provisions of Article 10.48.1.3, the limitations specified in Articles 10.57.1 and 10.57.2 shall apply to the modified

moments, but not to the original moments. Web bending-buckling shall be checked at overload according to Equation (10-173). For composite sections, D_c shall be calculated in accordance with Article 10.50(b). Sections that do not satisfy Equation (10-173) shall be modified to comply with the requirement.

10.57.1 Non-Composite Sections

At non-composite sections, the maximum overload flange stress shall not exceed $0.8F_y$.

10.57.2 Composite Sections

At composite sections, the maximum overload flange stress shall not exceed $0.95F_y$. In computing dead load stresses, the presence or absence of temporary supports during the construction shall be considered. For members with shear connectors provided throughout their entire length that also satisfy the provisions of Article 10.50.2.3, the overload flange stresses caused by loads acting on the appropriate composite section may be computed assuming the concrete deck to be fully effective for both positive and negative moment. For this case, the resulting stresses shall be combined with the stresses due to loads acting on the non-composite section to calculate D_c for checking web bend-buckling.

10.57.3 Slip-Critical Joints

10.57.3.1 In addition to the requirements of Articles 10.56.1.3.1 and 10.56.1.3.2 for fasteners, the force caused by the overload on a slip-critical joint shall not exceed the design slip strength, R_s (lb.), given by:

$$R_s = K_h \mu T_b A_n N_b N_s \quad (10-172)$$

where:

A_n = net cross section area of the bolt (in.²)

N_b = number of bolts in the joint

N_s = number of slip planes

T_b = required minimum bolt tension stress specified in the Standard Specifications of California Department of Transportation or equal to 70% of specified minimum tensile strength of bolts given in Table 10.2C (psi)

μ = slip coefficient specified in Table 10.57A

K_h = hole size factor specified in Table 10.57B

Class A, B or C surface conditions of the bolted parts as defined in Table 10.57A shall be used in joints designated as slip-critical except as permitted in Article 10.57.3.2.

High strength bolts done according to the Standard Specifications of the California Department of Transportation, Section 55, will be tensioned and the contact surface condition of the assembly will be Class B.

TABLE 10.57A Slip Coefficient μ

Class Types	Contact Surface of Bolted Parts	μ
Class A	Clean mill scale and blast-cleaned surfaces with Class A coating	0.33
Class B	Blast-cleaned surfaces and blast-cleaned surfaces with Class B coating	0.5
Class C	Hot-dip galvanized surfaces roughened by wire brushing after galvanizing	0.33

Note: Coatings classified as Class A or Class B include those coatings which provide a mean slip coefficient not less than 0.33 or 0.5, respectively, as determined by Testing Method to Determine the Slip Coefficient for Coatings Used in the Bolted Joints. See Article 10.32.3.2.3.

TABLE 10.57B Hole Size Factor Slip K_h

Hole Types	K_h
Standard	1.0
Oversize and Short-slotted	0.85
Long-slotted holes with the slot perpendicular to the direction of the force	0.70
Long-slotted holes with the slot parallel to the direction of the force	0.60

10.57.3.2 Subject to the approval of the Engineer, coatings providing a slip coefficient less than 0.33 may be used provided the mean slip coefficient is established by test in accordance with the requirements of Article



10.57.3.3, and the slip resistance per unit area established. The slip resistance per unit area shall be taken as equal to the slip resistance per unit area from Table 10.57A for Class A coatings as appropriate for the hole type and bolt type times the slip coefficient determined by test divided by 0.33.

10.57.3.3 Paint, used on the faying surfaces of connections specified to be slip critical, shall be qualified by test in accordance with "Test Method to Determine the Slip Coefficient for Coatings Used in Bolted Joints" as adopted by the Research Council on Structural Connections. See Appendix A of *Allowable Stress Design Specification for Structural Joints Using ASTM A 325 or A 490 Bolts*, published by the Research Council on Structural Connections.

10.57.3.4 For combined shear and tension in slip critical joints where applied forces reduce the total clamping force on the friction plane, the slip force shall not exceed the design slip strength given by:

$$R'_s = R_s (1 - 1.88 f_t / F_u) \quad (10-172b)$$

where:

- + f_t = calculated tensile stress in the bolt due to applied loads including any stress due to prying actions (psi)
- + R_s = design slip strength specified in Equation (10-172) (lb.)
- + F_u = specified minimum tensile strength of the bolt from Table 10.2C (psi)

10.58 FATIGUE

10.58.1 General

The analysis of the probability of fatigue of steel members or connection under service loads and the allowable range of stress for fatigue shall conform to Article 10.3, except that the limitation imposed by the basic criteria given in Article 10.3.1 shall not apply. For members with shear connectors provided throughout their entire length that also satisfy the provisions of Article 10.50.2.3, the range of stress may be computed using composite section assuming the concrete deck to be fully effective for both positive and negative moment.

10.58.2 Composite Construction

10.58.2.1 Slab Reinforcement

When composite action is provided in the negative moment region, the range of stress in slab reinforcement shall be limited to 20,000 psi.

10.58.2.2 Shear Connectors

The shear connectors shall be designed for fatigue in accordance with Article 10.38.5.1.

10.58.3 Hybrid Beams and Girders

Hybrid girders shall be designed for fatigue in accordance with Article 10.3.

10.59 DEFLECTION

The control of deflection of steel or of composite steel and concrete structures shall conform to the provision of Article 10.6.

10.60 ORTHOTROPIC SUPERSTRUCTURES

A rational analysis based on the Strength Design Method, in accordance with the specifications, will be considered as compliance with the specifications.

10.61 CONSTRUCTIBILITY

The Moment and shear capacity of a steel beam or girder shall meet the requirements specified below to control local buckling of the web and compression flange, and to prevent lateral torsional buckling of the cross section under the non-composite dead load prior to hardening of the deck slab. The casting or placing sequence of the concrete deck specified in plans shall be considered in determining the applied moments and shears. A load factor $\gamma = 1.3$ shall be used in calculating the applied moments and shears.

10.61.1 Web

The maximum factored non-composite dead load compressive bending stress in the web shall not exceed the allowable design bending stress given below:

$$F_b = \frac{26,200,000 a k}{\left(\frac{D}{t_w}\right)^2} \leq F_{yw} \quad (10-173)$$

where:

F_{yw} = specified minimum yield strength of the web (psi)

D_c = depth of the web of the steel beam or girder in compression (in.)

D = web depth (in.)

t_w = thickness of web (in.)

k = $9(D/D_c)^2$ for members without a longitudinal stiffener

a = 1.3 for members without a longitudinal stiffener

a = 1.0 for members with a longitudinal stiffener

Sections without longitudinal stiffeners that do not satisfy Equation (10-173) shall either be modified to comply with the requirement or a longitudinal stiffener shall be added to the web at a location on the web that satisfies both Equation (10-173) and all strength requirements, which may or may not correspond to the optimum location of the longitudinal stiffeners specified in Article 10.49.3.2(a). For longitudinally stiffened girders, the buckling coefficient, k is calculated as

for

$$\frac{d_s}{D_c} \geq 0.4 \quad k = 5.17 \left(\frac{D}{d_s}\right)^2 \geq 9\left(\frac{D}{D_c}\right)^2$$

for

$$\frac{d_s}{D_c} < 0.4 \quad k = 11.64 \left(\frac{D}{D_c - d_s}\right)^2$$

where:

d_s = distance from the centerline of a plate longitudinal stiffener or the gage line of an angle longitudinal stiffener to the inner surface or the leg of the compression flange component (in.)

The web thickness requirements specified in Articles 10.48.5.1, 10.48.6.1, 10.49.2 and 10.49.3.2(b) shall not be applied to the constructibility load case.

The sum of the factored non-composite and composite dead load shears shall not exceed design shear strength of the web specified in Article 10.48.8.1 (Equation 10-113).

10.61.2 Deleted

10.61.3 Cross Section

The maximum factored non-composite dead-load moment shall not exceed the value of M_u calculated for the steel beams or girder using the equations specified in Article 10.48.4.1.

10.61.4 Compression Flange

The ratio of the compression flange width to thickness in positive-moment regions shall meet the following requirement:

$$\frac{b}{t} \leq \frac{4,400}{\sqrt{f_{dl}}} \leq 24 \quad (10-174)$$

where:

f_{dl} = top-flange compressive stress due to the factored non-composite dead load divided by the factor R_b specified in Article 10.48.4.1, but not to exceed F_y . (psi)