

**California Transportation Permits Advisory Council (CTPAC)  
Steering Committee Meeting**

**Thursday, November 17<sup>th</sup>, 2022  
10:00 AM to 12:00 PM**

**Location: Caltrans District 12 Office  
1750 E. 4<sup>th</sup> Street, Santa Ana, CA 92705**

**Meeting Summary**

**Item #1 – Welcome, Agenda and Purpose of Meeting.**

CTPAC chairperson Eric Sauer, Chief Executive Officer of the California Trucking Association (CTA), welcomed attendees and especially thanked Caltrans District 12 Office for providing the facility. Eric appreciated everyone for participating in the meeting, including the trucking industry, the California Department of Transportation (Caltrans), the California Highway Patrol (CHP) representatives and Caltrans District 12 staff.

Bobi Hetick, District 12 Deputy District Director, and Karl Lindquist, District 12 Traffic Operations Office Chief, each welcomed the attendees to the District Office. Attendees started self-introductions to one another around the room, and a sign-in sheet was circulated during the meeting.

Eric asked members to review the proposed Advance Clean Fleets (ACF) regulation that would require all new medium and heavy-duty vehicle sales in the state to be zero-emission vehicles starting in 2040. The proposal will impact the truck industry greatly.

**Item #2 – Caltrans Updates**

Thomas Schriber, Chief of Caltrans' Office of Commercial Vehicle Operations (CVO), welcomed everyone at the meeting. Dan Brown, variance transportation permit writer responsible for variance permit processing and Armando Perez, construction liaison responsible for collecting vertical and horizontal clearance information are retired. Thomas also pointed out that August was the first month that had zero vacancies since he joined the CVO.

As mentioned in the previous meetings, CVO office has recently moved from 1823 14<sup>th</sup> Street to 1120 N street, Sacramento and mails sent to 14<sup>th</sup> street will be automatically forwarded to N street building. The new office has fewer cubicles compared to the old office and a few hotel cubicles for teleworking staff. CVO

is still setting up the new office and unpacking the boxes. As a result, there are maybe some delays in permit processing.

Caltrans Information technology (IT) staffs are still working on implementing electronic interface for annual and repetitive permits similar to STARS2.

In response to inspection report proposal, Caltrans proposes to develop a searchable repository of inspection reports allowing the customer to only turn in inspection reports once when applying for permits. However, it will take time to develop the program.

### **Item #3 – CHP Updates**

Sergeant Dave Kelly, CHP Commercial Vehicle Section (CVS), shared that CVS is going through some personnel changes and will ensure smooth connectivity through the transition. Lieutenant Nick Doko is currently the acting commander. In addition, Sergeant Dave Kelly shared the CHP regulatory actions web page with the members and encouraged everyone to regularly check the recently proposed or adopted regulations affecting commercial vehicles' operation within California.

<https://www.chp.ca.gov/News-Alerts/Regulatory-Actions>

### **Item #4 – Roundabouts on SHS**

Thomas announced that Brian Frazer from Caltrans Design retired recently, and his back-up cannot attend the meeting today. Here are some updates for roundabouts on the SHS.

Caltrans & the DMV met to discuss possible updates to the Commercial Driver's Handbook to include roundabout information for the commercial vehicle operator. The DMV was open and agreeable to including updates and there was no pushback from any party. Caltrans sent over potential handbook language to the DMV on Oct 2022 and updates are targeted to be included in the July 2023 update.

Updates include:

- Guidance for driving single and multiple lane roundabouts, including watching out for pedestrians and bicyclists
- Identifying truck aprons that have been designed specifically for truck off-tracking
- Including the option for commercial vehicles to straddle lanes as necessary to enter and traverse and multi-lane roundabout. (This guidance is also included in Highway Design Manual, so designers are aware that trucks prefer to use roundabouts this way)

- Additional roundabout types that may start popping up on the SHS, such as turbo roundabouts and mini roundabouts

Eric thanked everyone's efforts in updating Commercial Driver Handbook.

The roundabout section of Highway Design Manual was updated in May 2022 and includes the OS/OW vehicle shown below as a design vehicle check for roundabouts.

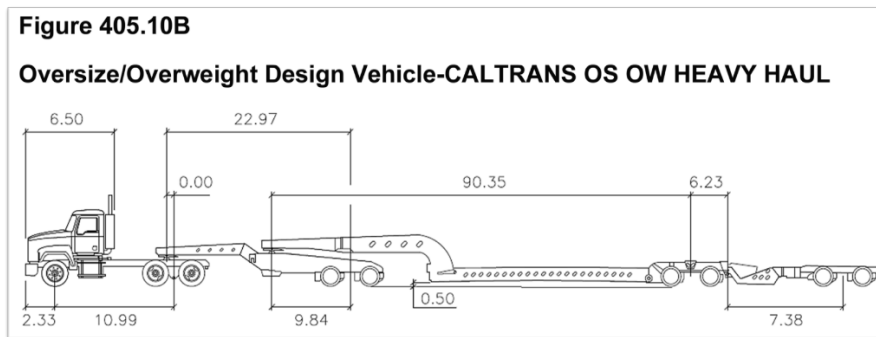

The Highway Design Manual updates also includes the requirement for the designer to coordinate with the District Truck Access Managers (DTAM) on other vehicle needs.

**Item #5 – Workgroup Updates**

**a) Crane**

Michael Vlaming could not join the meeting today and is still working on a proposal.

**b) Annuals**

No update.

**c) Fixed Loads/Tow Trucks**

No update.

**d) Variance**

Lorin Sabin said there are many inconsistencies in variance permit processing due to Dan Brown's retirement. Caltrans will follow up with the variance team.

**e) Inspection Report**

Caltrans has received a proposal from the Inspection Report Working Group and provided responses in item #6 below.

**Item #6 – Caltrans Action Items Updates**

Narayan Selwal, Chief of Transportation Permits Policies and Compliance / Legal Truck Access Branch shared some updates.

The revision of Transportation Permits Manual (TPM) Chapter 2 has been completed and published on the Caltrans website. <https://dot.ca.gov/-/media/dot-media/programs/traffic-operations/documents/transportation-permits/tpm/2022-cvo-transportation-permits-manual-chapter-2-a11y.pdf>

The paper copies of the TPM Chapter 1 revision were distributed during the meeting, and the electronic copy will be shared after the meeting.

Comments/inputs are valuable and highly appreciated.

A wide load collision occurred on Plumas County SR-70 on 4/20/2022. The load was not required to have a CHP escort. Dimensions were 14'8" wide, 110' long, with a KPRA of 60' and trailer length of 72'. Per CHP, travel with those dimensions is impossible without occupying the opposing lane in various locations. The office of CVO then reached out to District 2 DTAM for route reclassification and red route summary modification. District 2 DTAM spoke with all stakeholders and CTA to collect information to complete the request and still waiting for responses. In the meantime, District 2 DTAM is proceeding with analysis using the smallest manufactured home dimensions possible and is 50% completed. Once analysis is completed and stakeholders' inputs are received, District 2 will finalize reclassifications and red route summary table changes.

Suzanne Scheideker Cook said it would be very helpful to document the history of a red route modification, such as the reasons for change. She suggested that information could be kept in a centralized statewide repository.

Regarding CTPAC Work Group's Proposal of Inspection Report, Caltrans agreed with the concept that customers only need to submit an inspection report once when applying for permits. However, at this point, Caltrans does not have a searchable electronic repository for inspection reports. CVO is working with IT staff to develop a searchable database. Until a repository (or database) has been developed to house Inspection Reports, the proposal cannot be implemented.

For information sharing purpose, Narayan informed that Caltrans is going to add California Truck Network Map and Truck Weigh Station locations in Caltrans QuickMap. Narayan demonstrated the test version of the QuickMap. The map will be available in both web version and mobile versions (both in IOS and Android). Narayan encouraged members to download the QuickMap app if

they have not used it and demonstrated how to use the app. Members found it very useful.

### **Item #7 Southern California Truck Route Closures**

Eric shared that over the past couple of years some cities in the Southern California region have been illegally declassifying legal truck routes. This has led to neighboring cities seeing an increase of trucks that has led them to doing the same thing. Local cities do not have jurisdiction to close the ramp without going through the proper process, including notifying the public and neighboring jurisdictions.

### **Item #8 Public comments**

Q: Can we have access to bridge inventory from SM&I?

A: Summer Silveira responded that the bridge inventory will provide to the members upon request.

### **Item #9 – Summarize Action Items from Meeting**

Eric summarized the following action items.

- 1) Variance procedures.  
Thomas will follow up with the variance group regarding inconsistency in permit processing, and it would be helpful if the industry could provide some denial permit applications. Eric will work with Lorin to collect some examples. It will also be beneficial if the variance permit customer can work with SM&I directly to discuss possible routes.
- 2) Eric and Lorin will work on a band-aid solution while Caltrans develops a searchable database for inspection reports.
- 3) CTPAC members and CHP will review the TPM Chapter 1 revision and provide comments by January 16, 2023.
- 4) Stakeholders and CTA will follow up with District 2 DTAM regarding Plumas Route 70 red route request. District 2 Contact: Jesse Solorio, (530)-215-8353.
- 5) SM&I will provide bridge inventory to Eric, and Eric will send out bridge inventory to members upon request.
- 6) Eric will send out an email to encourage members and Caltrans to attend WASHTO annual meeting to increase participation.

### **Item #10: Next Meeting**

The next CTPAC meeting will be held at Carlsbad and tentatively scheduled in April 2023.

**Item #11 – Adjourn**

The meeting was adjourned by Eric Sauer.

CTPAC Action Items

No.	CTPAC Meeting	Item	Due Date	Status/Notes
1	2/18/2016	Roundabout presentation - create advisory committee of CTPAC representatives (Leon F., Tim M., Lorin S., Curt W.)		<p><u>06/17/21</u>: Eric will include roundabout discussion to the agenda at the next meeting.</p> <p><u>10/06/21</u>: Brian Frazer of Caltrans Design presented. See Item 5 below.</p> <p><u>02/10/22</u>: Brian Frazer of Caltrans Design presented. See Item 5 below.</p> <p><u>06/30/22</u>: Brian Frazer of Caltrans Design presented. See Item 5 below.</p> <p><u>11/17/22</u>: Brian Frazer retired. See Item 5 below.</p>
2	4/22/2019	Annual electronic copy of truck permit to replace hardcopy permit		<p><u>01/16/20</u>: Kien stated that there are no reasons that annual electronic copy of truck permit should replace hardcopy permit given the frequency of usage. Kien fully supported the electronic copy of the single trip permit, but not annual permit. The haulers should always keep the permit in possession.</p> <p><u>06/17/21</u>: Caltrans is working with IT Division to develop an online system that allows the customers to submit the permit applications electronically, including</p>

No.	CTPAC Meeting	Item	Due Date	Status/Notes
				<p>annual, repetitive and sea container.  <u>10/06/21</u>: On-going.  <u>02/10/22</u>: Three information technology staff are currently working on an online interface system for applying and issuing annual, repetitive, and sea container transportation permits.  <u>06/30/22</u>: on-going.    <u>11/17/22</u>: on-going.</p>
3	9/12/2019	<p>Framed Load Bed Permit Issue from Oversize Transfer Trucking Inc.</p> <p>Greg Sanden emailed regarding permit for framed load bed container that typical sits at 4' high on framed flat rack to travel in the LA/LB Heavy Corridor.</p>		<p><u>9/22/2019</u>: Greg Sanden will contact Caltrans' Permit Office to resolve the issue. The sizes of the loads are vary widely – Will look into details. Single trip permits might be issued.  <u>01/16/20</u>: Greg Sanden was not present at the meeting.  <u>10/01/20</u>: No update.  <u>02/16/21</u>: No update.  <u>06/17/21</u>: No update.  <u>10/06/21</u>: No update.  <u>02/10/22</u>: No update.  <u>06/30/22</u>: No update.    <u>11/17/22</u>: No update.</p>
4	10/01/2020	<p>Port of Long Beach asked members to provide support letters regarding the expansion project on Anaheim Way and Farragut Avenue.</p>		<p>On-going</p> <p><u>02/16/21</u>: No update.  <u>06/17/21</u>: No update.  <u>10/06/21</u>: Port of Long Beach asked members to provide support letters regarding the expansion</p>



No.	CTPAC Meeting	Item	Due Date	Status/Notes
				<p>project on Anaheim Way and Farragut Avenue.  <u>02/10/22</u>: No update.  <u>06/30/22</u>: No update.</p> <p><u>11/17/22</u>: No update.</p>
5	10/06/2021	<p>Brian Frazer of Caltrans Design - Roundabouts - Described industry role in providing feedback. Discussed possible changes to CVC and CA Commercial Drivers Handbook.</p>		<p>On-going  <u>02/10/22</u>: Eric will reach out to DMV to discuss the possible updates of Commercial Driver Handbook. Eric will follow up with possible changes to CVC.  <u>06/30/22</u>: Follow up meeting by CHP, CTA, and Caltrans on possible vehicle code changes and changes to Commercial Drivers Handbook related to commercial vehicles in roundabouts. Industry will review the locations of where the roundabouts are being planned and provide comments.</p> <p><u>11/17/22</u>: DMV is agreed to include roundabouts info in the July 2023 update.</p>
6	10/06/2021	<p>Inspection Report Requirements:</p> <p>Permits Processing  1. Inspection report requirements for California haulers – CT</p>		<p><u>10/27/2021</u>: Caltrans issued clarification memo regarding inspection report requirements.  <u>02/10/22</u>:  1. Caltrans met with industry virtually on 6</p>

No.	CTPAC Meeting	Item	Due Date	Status/Notes
		<p>Permits will issue clarification MEMO and update permit writers via training.</p> <p>2. Two tiered variances. Brad Tuttle will follow up with Permits Manager Devinder Sandhu via Webex, on or before week ending 10/22/2021</p>		<p>January 2022 to clarify the inspection report requirement memo. Work group is formed to review vehicle inspection requirements. Eric will provide a list of inspection report work group members.</p> <p>2. Caltrans met with Bragg Heavy Transport virtually in October 2021 to discuss the issues related to two tiered variances and issues resolved.</p> <p><u>06/30/22</u>: Work group submitted inspection report proposal. Caltrans will review the proposal and provide feedback.</p> <p><u>11/17/22</u>: Caltrans provided feedback and is working with IT to develop a searchable database for inspection reports. Eric and Lorin will work on a band-aid solution while Caltrans develops a searchable database for inspection reports.</p>
7	06/30/2022	Additional \$50 charge on variance permits when the work was already done on a previous permit.		<p><u>06/30/22</u>: Caltrans will clarify with the variance team on additional charges and provide feedback.</p> <p>11/17/22: No update.</p>

No.	CTPAC Meeting	Item	Due Date	Status/Notes
8	06/30/2022	SR 70 Red Route		<p>06/30/22: Caltrans HQ will follow up with the district and CHP regarding SR 70 red route.</p> <p><u>11/17/22</u>: Stakeholders and CTA will follow up with District 2 DTAM to provide relevant information regarding Plumas Route 70 red route request.</p>
9	11/17/2022	Variance procedures		<p><u>11/17/22</u>: Thomas will follow up with the variance group regarding inconsistency in permit processing, and the industry will provide some examples.</p>
10	11/17/22	TPM Chapter 1 revision		<p><u>11/17/22</u>: CTPAC members and CHP will review the TPM Chapter 1 revision and provide comments by January 16, 2023.</p>