

DIST	COUNTY	ROUTE	POST MILES TOTAL PROJECT	SHEET No.	TOTAL SHEETS
					>

REGISTERED CIVIL ENGINEER DATE \_\_\_\_\_

PLANS APPROVAL DATE \_\_\_\_\_

The State of California or its officers or agents shall not be responsible for the accuracy or completeness of scanned copies of this plan sheet.

The Registered Civil Engineer for the project is responsible for the selection and proper application of the component design and any modifications shown.

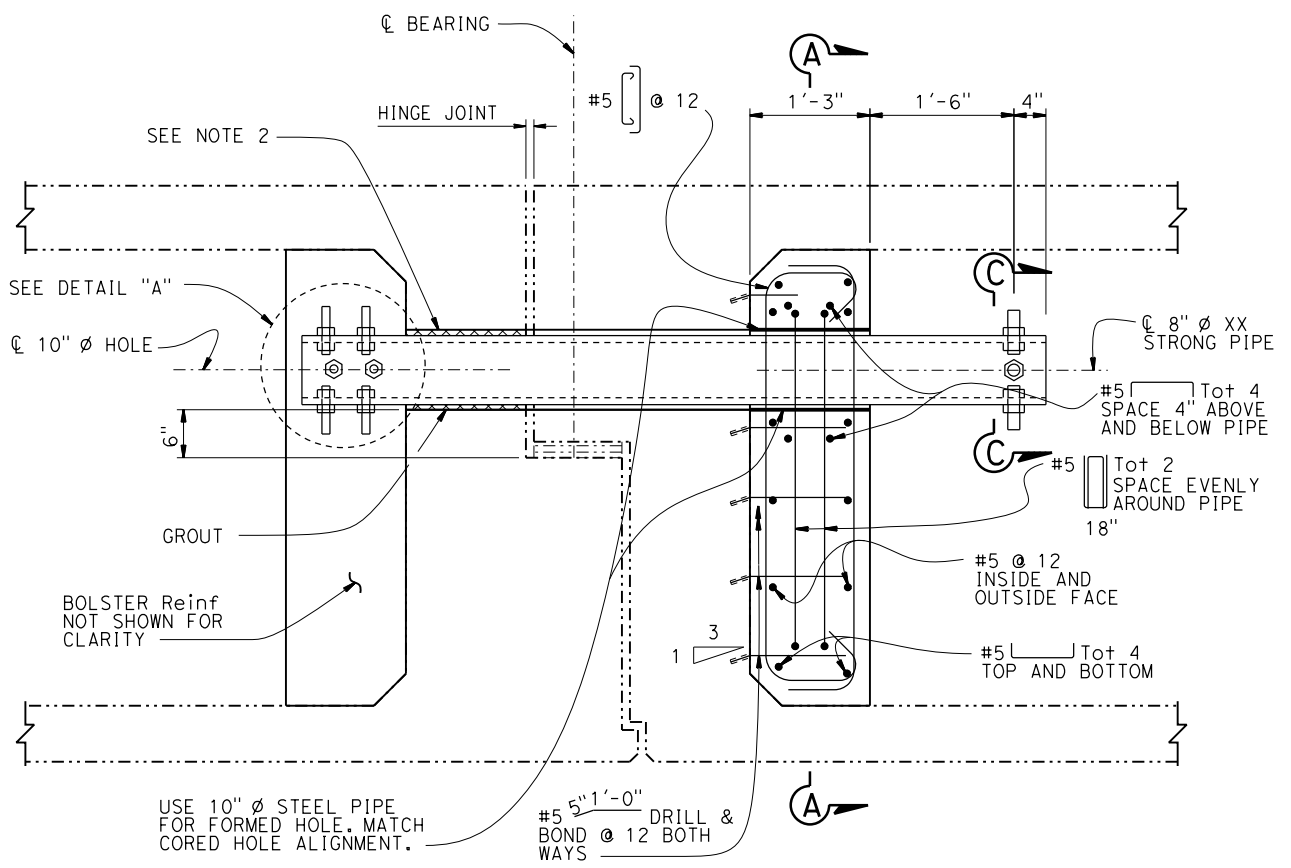
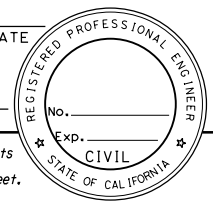

**PIPE EXTENDER ELEVATION**  
NO SCALE

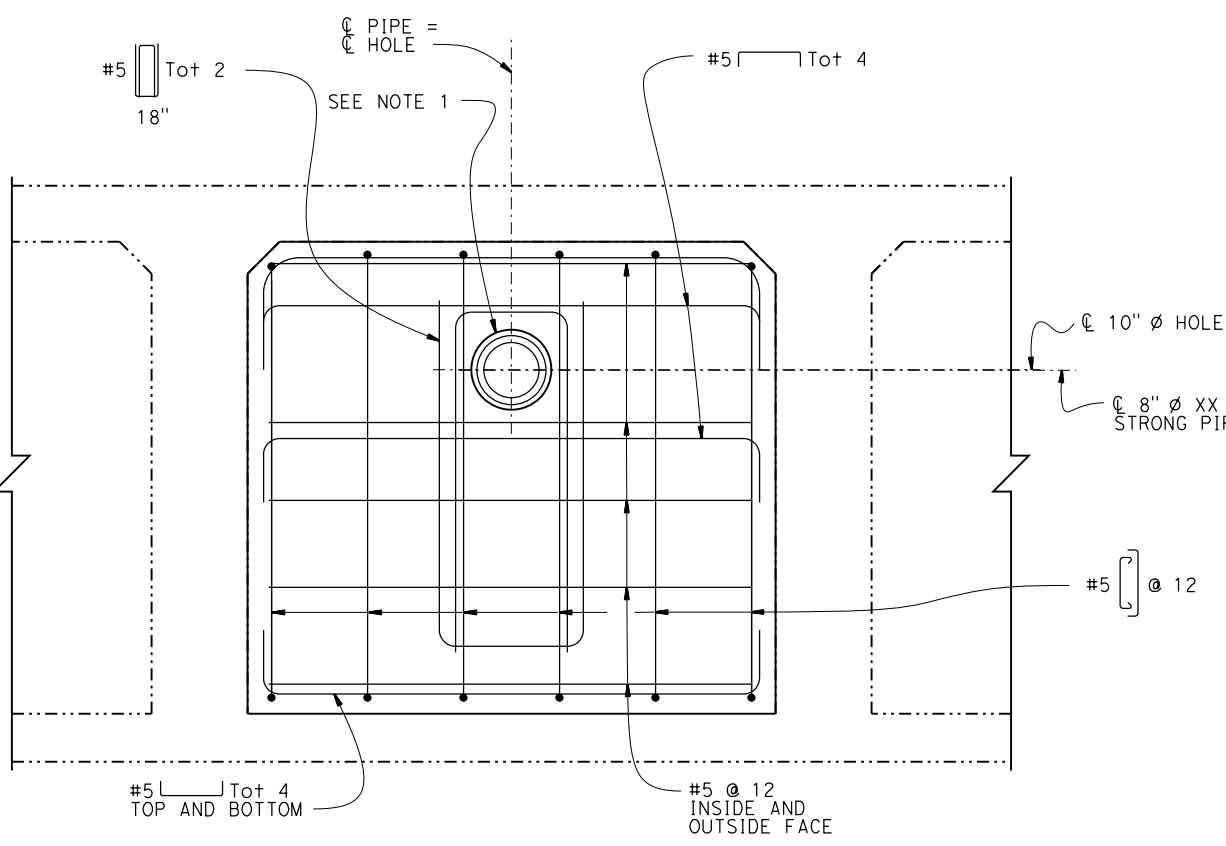

**SECTION A-A**  
NO SCALE

- PIPE SEAT EXTENDER NOTES**
1. Core 10" hole parallel to girders for 8" XX Strong pipe.
  2. Place pipe 3/4" down from top of cored hole along the entire length and grout annulus space around the support end of pipe prior to placing bolster concrete. Seal end of grouted region to prevent grout from entering hinge opening.
  3. Adjust bolster reinforcement to accommodate bridges with skews.
  4. If equalizer bolts are encountered, adjust cored hole horizontally to clear bolts by 6".
  5. Galvanize 8" XX Strong pipe. Paint inside drilled holes, ends, and outside surfaces of pipe that are not galvanized with zinc rich primer.
  6. Block out bolsters to allow drainage of soffit vents as needed.
  7. Use thread locking system. Torque to 300 ft-lb min.
  8. Adjust C of drilled hole for HS Threaded Rods so the tip of Rod has 2" min cover concrete.

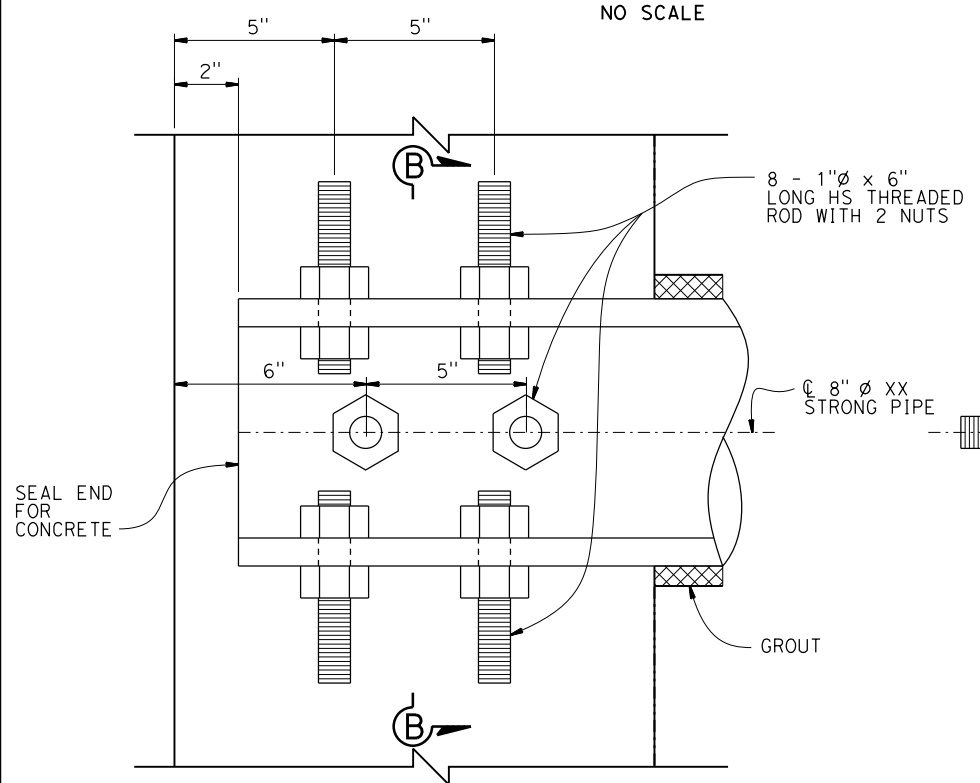

**DETAIL "A"**  
NO SCALE

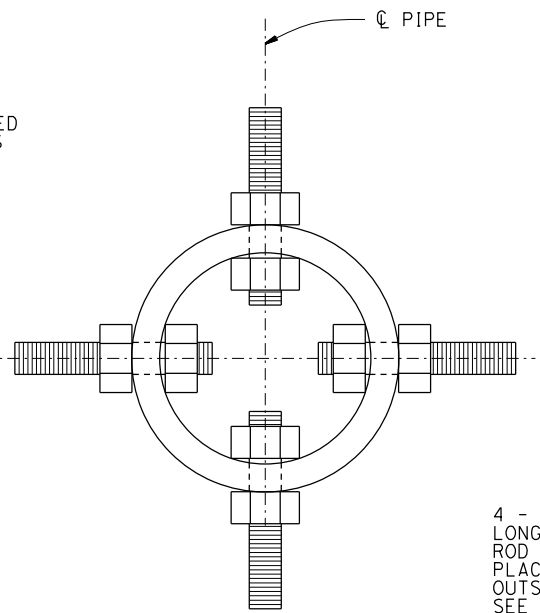

**SECTION B-B**  
NO SCALE

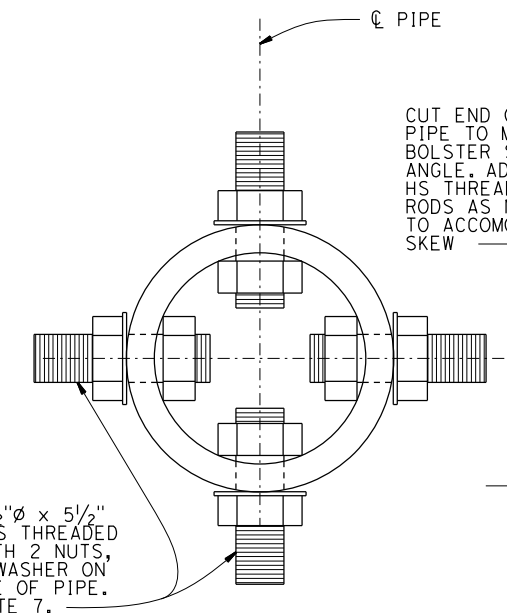

**SECTION C-C**  
NO SCALE

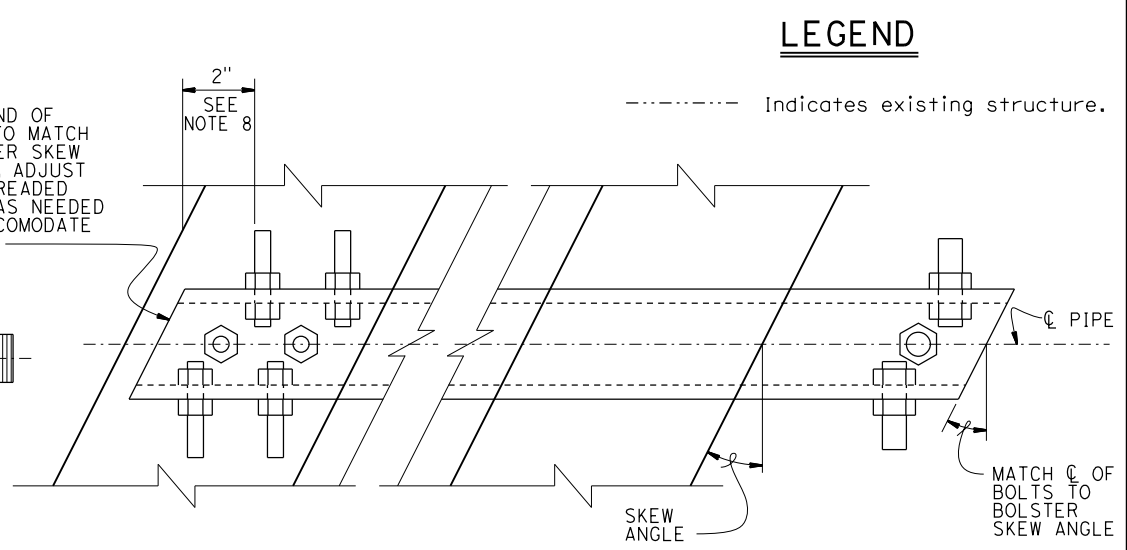

**PART PLAN**  
**BRIDGES WITH SKEWS**  
NO SCALE

**LEGEND**  
----- Indicates existing structure.

**BRIDGE STANDARD DETAILS**

<b>xs7-083</b> FILE NO.	October 2016 APPROVAL DATE	The components of the Bridge Standard Details have been prepared under the responsible charge of the Technical Owner, a registered civil engineer in the State of California.
----------------------------	-------------------------------	---

FILE => \$REQUEST	USERNAME => \$USER	TIME PLOTTED => \$TIME	DATE PLOTTED => \$DATE
-------------------	--------------------	------------------------	------------------------

**STATE OF CALIFORNIA**  
DEPARTMENT OF TRANSPORTATION

**DIVISION OF ENGINEERING SERVICES**

BRIDGE NO.	
POST MILE	
<b>135 KIP PIPE SEAT EXTENDER (RETROFIT)</b>	