

CHAPTER 2G. PREFERENTIAL AND MANAGED LANE SIGNS

Section 2G.01 Scope

Support:

01 Preferential lanes are lanes designated for special traffic uses such as high-occupancy vehicles (HOVs), light rail, buses, taxis, or bicycles. Preferential lane treatments might be as simple as restricting a turning lane to a certain class of vehicles during peak periods, or as sophisticated as providing a separate roadway system within a highway corridor for certain vehicles.

02 Preferential lanes might be barrier-separated (on a separate alignment or physically separated from the other travel lanes by a barrier or median), buffer-separated (separated from the adjacent general-purpose lanes only by a narrow buffer area created with longitudinal pavement markings), or contiguous (separated from the adjacent general-purpose lanes only by a lane line). Preferential lanes might allow continuous access with the adjacent general-purpose lanes or restrict access only to designated locations. Preferential lanes might be operated in a constant direction or operated as reversible lanes. Some reversible preferential lanes on a divided highway might be operated counter-flow to the direction of traffic on the immediately adjacent general-purpose lanes.

03 Preferential lanes might be operated on a 24-hour basis, for extended periods of the day, during peak travel periods only, during special events, or during other activities.

04 Open-road tolling lanes and toll plaza lanes that segregate traffic based on payment method are not considered preferential lanes. Chapter 2F contains information regarding signing of open-road tolling lanes and toll plaza lanes.

05 Managed lanes typically restrict access with the adjacent general-purpose lanes to designated locations only.

06 Under certain operational strategies, such as the occupancy requirement of an HOV lane changing in response to actual congestion levels, a managed lane is a special type of preferential lane (see Sections 2G.03 through 2G.07).

07 A managed lane operated on a real-time basis in response to changing conditions might be operated as an HOV lane for a period of time as needed to manage congestion levels.

08 Sections 2G.16 through 2G.18 contain additional information regarding signs for managed lanes that use tolling or pricing as a management strategy.

09 Section 9B.04 contains information regarding Preferential Lane signs for bike lanes.

Section 2G.02 Sizes of Preferential and Managed Lane Signs

Standard:

01 **Except as provided in Section 2A.11, the sizes of preferential and managed lane signs that have standardized designs shall be as shown in Table 2G-1.**

Support:

02 Section 2A.11 contains information regarding the applicability of the various columns in Table 2G-1.

Option:

03 Signs larger than those shown in Table 2G-1 may be used (see Section 2A.11).

Section 2G.03 Regulatory Signs for Preferential Lanes – General

Standard:

01 **When a preferential lane is established, the Preferential Lane regulatory signs (see Figure 2G-1) and pavement markings (see Chapter 3D) for these lanes shall be used to advise road users.**

Support:

02 Preferential Lane (~~R3-10 series~~ [R3-11 series](#) through R3-15 series, [R82B\(CA\) through R88\(CA\)](#), [R91\(CA\) series through R94\(CA\)](#), [SR50\(CA\) series](#) and the [SR60\(CA\) series](#)) regulatory signs consist of several different general types of regulatory signs as follows (see Figure 2G-1 and [Figure 2G-1\(CA\)](#)):

A. Vehicle Occupancy Definition signs define the vehicle occupancy requirements applicable to an HOV lane (such as “2 OR MORE PERSONS PER VEHICLE”) or types of vehicles not meeting the minimum

occupancy requirement (such as motorcycles or ILEVs) that are allowed to use an HOV lane (see Section 2G.04).

- B. Periods of Operation signs notify road users of the days and hours during which the preferential restrictions are in effect (see Section 2G.05).
- C. Preferential Lane Advance signs notify road users that a preferential lane restriction begins ahead (see Section 2G.06).
- D. Preferential Lane Ends signs notify users of the termination point of the preferential lane restrictions (see Section 2G.07).

Standard:

03 Regulatory signs applicable only to a preferential lane shall be distinguished from regulatory signs applicable to general-purpose lanes by the inclusion of the applicable symbol(s) and/or word(s) (see Figure 2G-1 and Figure 2G-1(CA)).

Support:

04 The symbol and word message displayed on a particular Preferential Lane regulatory sign will vary based on the specific type of allowed traffic and on other related operational constraints that have been established for a particular lane, such as an HOV lane, a bus lane, or a taxi lane.

Option:

05 Changeable message signs may supplement, substitute for, or be incorporated into static Preferential Lane regulatory signs where travel conditions change or where multiple types of operational strategies (such as variable occupancy requirements or vehicle types) are used and varied throughout the day or week, or on a real-time basis, to manage the use of, control of, or access to preferential lanes.

Support:

06 Figure 2G-1 illustrates examples of changeable messages incorporated into static Preferential Lane regulatory signs.

Standard:

07 When changeable message signs (see Chapter 2L) are used as regulatory signs for preferential lanes, they shall be the required sign size and shall display the required letter height and legend format that corresponds to the type of roadway facility and design speed.

Guidance:

08 *When Preferential Lane regulatory signs are used on conventional roads, the decision regarding whether to use a post-mounted or overhead version of a particular type of sign should be based on an engineering study that considers the available space, the existing signs for the adjacent general-purpose traffic lanes, roadway and traffic characteristics, the proximity to existing overhead signs, the ability to install overhead signs, and any other unique local factors.*

09 *If overhead regulatory signs applicable only to a preferential lane are located in approximately the same longitudinal position along the highway as overhead signs applicable only to the general-purpose lanes, the signs for the preferential lane should be separated laterally from the signs for the general-purpose lanes to the maximum extent practical to minimize conflicting information, while maintaining their visual relationship to the lanes below necessitated by specific legend or arrows indicating lane assignment.*

Standard:

10 If used, overhead Preferential Lane (R3-13 series, R3-14 series, ~~and~~ R3-15 series, and R87(CA) series) regulatory signs shall be installed on the side of the roadway where the entrance to the preferential lane is located and any appropriate adjustments shall be made to the sign message.

Option:

11 Where a median of sufficient width is available, the R3-13 series and R3-15 series signs may be post-mounted.

Support:

12 The sizes for Preferential Lane regulatory signs will differ to reflect the design speeds for each type of roadway facility. Table 2G-1 provides sizes for each type of roadway facility.

Guidance:

13 *The edges of Preferential Lane regulatory signs that are post-mounted on a median barrier should not project beyond the outer edges of the barrier, including in areas where lateral clearance is limited.*

Option:

¹⁴ Where lateral clearance is limited, Preferential Lane regulatory signs that are post-mounted on a median barrier and that are 72 inches or less in width may be skewed up to 45 degrees in order to fit within the barrier width or may be mounted higher, such that the vertical clearance to the bottom of the sign, light fixture, or structural support, whichever is lowest, is not less than 14 feet above any portion of the pavement and shoulders.

Standard:

¹⁵ **Where lateral clearance is limited, Preferential Lane regulatory signs that are post-mounted on a median barrier and that are wider than 72 inches shall be mounted with a vertical clearance that complies with the provisions of Section 2A.18 for overhead mounting.**

Guidance:

¹⁶ *On conventional roadways, Preferential Lane regulatory sign spacing should be determined by engineering judgment based on speed, block length, distances from adjacent intersections, and other site-specific considerations.*

Support:

¹⁷ Sections 2G.04 and 2G.05 contain provisions regarding the placement of Preferential Lane regulatory signs on freeways and expressways.

Standard:

¹⁸ **The signs illustrated in Figure 2G-1 and Figure 2G-1(CA) that incorporate the diamond symbol shall be used exclusively with preferential lanes for high-occupancy vehicles to indicate the particular occupancy requirement and time restrictions applying to that lane. The signs illustrated in Figure 2G-1 that do not have a diamond symbol shall be used with preferential lanes that are not HOV lanes, but are designated for use by other types of vehicles (such as bus and/or taxi use).**

Option:

¹⁹ Agencies may select from either the HOV abbreviation or the diamond symbol, or use both, to reference the HOV lane designation.

Standard:

²⁰ **When the diamond symbol (or HOV abbreviation) is used without text on the post-mounted Preferential Lane (~~R3-10 series~~, R3-11 series, and R3-12 series, **R93-2(CA)**, and **SR50-2(CA)**) regulatory signs, it shall be centered on the top line of the sign. When the diamond symbol (or HOV abbreviation) is used with associated text on the post-mounted Preferential Lane (~~R3-10 series~~, R3-11 series, and R3-12 series, **R82-1(CA)**, **R84-2(CA)**, **R86(CA) series**, **R88(CA)**, and **R91(CA) series**) regulatory signs, it shall appear to the left of the associated text. When the diamond symbol is used on the overhead Preferential Lane (R3-13, R3-13a, R3-14, and R3-14a, and **R87(CA) series**) regulatory signs, it shall appear in the top left quadrant. The diamond symbol for the R3-15, R3-15a, R3-15b, and R3-15c, and **SR50-1(CA)** signs shall appear on the left side of the sign. The diamond symbol shall not be used on the bus, taxi, or bicycle Preferential Lane signs.**

²¹ **Vehicle Occupancy Definition, Periods of Operation, and Preferential Lane Advance regulatory signs for HOV lanes shall display the minimum allowable vehicle occupancy requirement established for each HOV lane, displayed immediately after the word message HOV or the diamond symbol.**

Support:

²² The agencies that own and operate HOV lanes have the authority and responsibility to determine how they are operated and the minimum occupancy requirements. Information about federal requirements for certain types of vehicles not meeting the minimum occupancy requirement to be eligible to use HOV lanes that receive Federal-aid program funding and about requirements associated with proposed significant changes to the operation of an existing HOV lane and certain vehicles are contained in the "Federal-Aid Highway Program Guidance on High Occupancy Vehicle (HOV) Lanes" (see Section 1A.11).

Standard:

²³ **The provisions of Sections 2G.03 through 2G.07 regarding regulatory signs for Preferential lanes shall apply to managed lanes operated at all times or at certain times by varying vehicle occupancy requirements (HOV) or by using vehicle type restrictions as a congestion management strategy. Such managed lanes shall use changeable message signs or changeable message elements within static signs to display the appropriate regulatory sign messages only when they are in effect.**

24 When certain types of vehicles (such as trucks) are prohibited from using a managed lane or when a managed lane is restricted to use by only certain types of vehicles during certain operational strategies, regulatory signs or regulatory panels within the appropriate guide signs that include changeable message elements shall be used to display the open/closed status of the managed lane for such vehicle types.

25 When the vehicle occupancy required for use of an HOV lane is varied as a part of a managed lane operational strategy, regulatory signs that include changeable message elements shall be used to display the required vehicle occupancy in effect.

Support:

26 See Section 2G.17 for regulatory signs for managed lanes that use tolling or pricing as a congestion management strategy, either exclusively or with other management strategies.

27 Figures 2G-2 and 2G-3 illustrate the use of regulatory signs for the beginning, along the length, and at the end of contiguous or buffer-separated preferential lanes that provide continuous access with the adjacent general-purpose lanes.

Support:

28 For State highways, see Caltrans' High Occupancy Vehicle (HOV) Guidelines. See Section 1A.11 for information regarding this publication.

29 Refer to CVC 21655.5 for Exclusive- or Preferential-Use Lanes for High Occupancy Vehicles.

30 Refer to Figure 2G-1(CA) for Preferential Lane Regulatory Signs and Plaques.

Section 2G.04 Preferential Lane Vehicle Occupancy Definition Regulatory Signs (R3-10 Series and R3-13 Series)

Standard:

01 The R3-10, R3-13, and R3-13a, and R93-2(CA) Vehicle Occupancy Definition signs (see Figure 2G-1 and Figure 2G-1(CA)) shall be used where agencies determine that it is appropriate to provide a sign that defines the minimum occupancy of vehicles that are allowed to use an HOV lane.

Guidance:

02 *The Inherently Low Emission Vehicle (ILEV) (R3-10a) sign (see Figure 2G-1) should be used when it is permissible for a properly labeled and certified ILEV, regardless of the number of occupants, to use an HOV lane. When used, the ILEV signs should be post mounted in advance of and at intervals along the HOV lane based upon engineering judgment and the placement of other Preferential Lane regulatory signs. The R3-10a sign is only applicable to HOV lanes and should not to be used with other preferential lane applications.*

Support:

03 ILEVs are defined by the Environmental Protection Agency (EPA) as vehicles having no fuel vapor (hydrocarbon) emissions and are certified by the EPA as meeting the emissions standards and requirements specified in 40 CFR 88.311-93 and 40 CFR 88.312-93(e).

Guidance:

03a *The VEHICLES WITH DMV CLEAN AIR DECALOK (R93A(CA)) sign should be used when it is permissible for a properly labeled and certified low or zero emission vehicle, regardless of the number of occupants, to use an HOV lane. Refer to CVC 21655.9.*

03b *The R93A(CA) should be used in advance of and at intervals along the HOV lane based on engineering judgment.*

Standard:

03c **When used, the R93A(CA) sign shall be placed below the R93-2(CA) sign.**

Option:

03d The AUTOS/PICKUPS 2 SEATERS WITH 2 PERSONS OK (R91B(CA)) sign may be placed below the R93-2(CA) sign for preferential lane facilities at toll plazas that require 3 or more persons per vehicle but can also be utilized by vehicles designed by the manufacturer to be occupied by no more than 2 persons. Refer to Streets & Highways Code, Section 30101.8.

Guidance:

04 *The legend format of the R3-10 and R3-13 signs should have the following sequence:*

A. Top Line: "HOV 2+ ONLY" (or 3+ or 4+ if appropriate)

B. Bottom Lines: "2 OR MORE PERSONS PER VEHICLE" (or 3 or 4 if appropriate)

05 The legend format of the R3-13a sign should have the following sequence:

- A. Top Line: "HOV 2+ ONLY" (or 3+ or 4+ if appropriate)*
- B. Middle Lines: "2 OR MORE PERSONS PER VEHICLE" (or 3 or 4 if appropriate)*
- C. Bottom Lines: Times and days the occupancy restriction is in effect*

05a The legend format of the R93-2(CA) sign should have the following sequence:

- A. Top Line: "HOV 2+ IS" (or 3+ or 4+ if appropriate)*
- B. Bottom Lines: "2 OR MORE PERSONS PER VEHICLE" (or 3 or 4 if appropriate)*

Support:

06 Section 2G.17 contains information regarding the legends of Vehicle Occupancy Definition signs for a priced managed lane that has an occupancy requirement for non-toll travel.

Standard:

07 For barrier- or buffer-separated or contiguous preferential lanes where access between the preferential and general-purpose lanes is restricted to designated locations, an overhead Vehicle Occupancy Definition (R3-13 or R3-13a) sign shall be installed at least 1/2 mile in advance of the beginning of or initial entry point to an HOV lane. ~~These signs shall only be displayed in advance of the beginning of or initial entry point to HOV lanes.~~

Guidance:

07a The R3-13 or R3-13a sign should be installed at least 1/4 mile in advance of any intermediate access points or gaps in the barrier where vehicles are allowed to legally access the access-restricted preferential lanes.

Option:

08 For barrier-separated HOV lanes, the sequence of a post-mounted Periods of Operation (R3-11a or R86(CA) series) sign followed by a post-mounted Vehicle Occupancy Definition (~~R3-10~~) (R93-2(CA)) sign may be located at intervals of approximately 1/2 mile along the length of the HOV lane, at intermediate entry points, and at ~~designated enforcement areas as defined by the operating agency~~ downstream of direct access ramps.

Standard:

09 For buffer-separated or contiguous HOV lanes where access is restricted to designated locations, the sequence of a post-mounted Periods of Operation (R3-11a or R86(CA) series) sign followed by a post-mounted Vehicle Occupancy Definition (~~R3-10~~) (R93-2(CA)) sign shall be located at intervals not greater than 1/2 mile along the length of the access-restricted HOV lane, at designated gaps where vehicles are allowed to legally access the HOV lane, and ~~within designated enforcement areas as defined by the operating agency.~~ downstream of direct access ramps.

10 For ~~buffer-separated or~~ contiguous HOV lanes where continuous access with the adjacent general-purpose lanes is provided, the sequence of a post-mounted Periods of Operation (R3-11a or R86(CA) series) sign followed by a post-mounted Vehicle Occupancy Definition (~~R3-10~~) (R93-2(CA)) sign, and HLEV (~~R3-10a~~) signs if appropriate, shall be located at intervals not greater than 1/2 mile along the length of the HOV lane.

Guidance:

11 The signs within each Preferential Lane regulatory sign sequence should be separated by a minimum distance of 800 feet and a maximum distance of 1,000 feet.

Standard:

12 For all types of direct access ramps that provide access to or lead to HOV lanes, a post-mounted Vehicle Occupancy Definition (~~R3-10~~) (R93-2(CA)) sign, and an HLEV (~~R3-10a~~) sign if appropriate, shall be used at the beginning or initial entry point for the direct access ramp.

Option:

12a The (HOV) NO TRUCKS 3 AXLES OR MORE – NO VEHICLES WITH TRAILERS (R91-4(CA)) sign may be placed adjacent to the HOV lane, as needed, where incidences of trucks or vehicles with trailers in the HOV lanes have commonly occurred and on surface streets approaching direct access ramps that provide access to or lead to HOV lanes.

Section 2G.05 Preferential Lane Periods of Operation Regulatory Signs (R3-11 Series and R3-14 Series)

Guidance:

⁰¹ *The sizes of post-mounted Periods of Operation (R3-11 series, R86(CA) series, and SR60-3(CA) through SR60-7(CA)) signs should remain consistent to accommodate any manual addition or removal of a single line of text for each sign.*

Support:

⁰² Consistent sign sizes are beneficial for agencies when ordering sign materials, as well as when making text changes to existing signs if changes occur to operating times or occupancy restrictions in the future. For example, the R3-11e sign has space for one line located below "24 HOURS" if an agency determines that it is appropriate to display additional information (such as "MON-FRI"), yet the R3-11e sign has the same dimensions as the other R3-11 series signs.

Standard:

⁰³ **When used, the post-mounted Periods of Operation (R3-11 series, R86(CA) series, and SR60-3(CA) through SR60-7(CA)) signs shall be located adjacent to the preferential lane, and the overhead Periods of Operation (R3-14 series, R3-14c, R87-3(CA), SR60-8(CA) and SR60-9(CA)) signs shall be mounted directly over the lane.**

⁰⁴ **The legend format of the post-mounted Periods of Operation (R3-11 series, R86(CA) series, and SR60-3(CA) through SR60-7(CA)) signs shall have the following sequence:**

- A. **Top Lines:** Lanes applicable, such as "RIGHT LANE" or "2 RIGHT LANES" or "THIS LANE"
- B. **Middle Lines:** Eligible uses, such as "HOV 2+ ONLY" (or 3+ or 4+ if appropriate) or "BUSES ONLY" or other applicable uses or eligible turning movements
- C. **Bottom Lines:** Applicable times and days, such as "7 AM – 9 AM" or "6:30 AM – 9:30 AM, MON-FRI" or "24 HOURS".

⁰⁵ **The legend format of the overhead Periods of Operation (R3-14 series and R87-3(CA)) signs shall have the following sequence:**

- A. **Top Line:** Eligible uses, such as "HOV 2+ ONLY" (or 3+ or 4+ if appropriate) or "BUSES ONLY" or other applicable uses or eligible turning movements
- B. **Bottom Lines:** Applicable times and days, with the time and day placed above the down arrow, such as "7 AM – 9 AM" or "6:30 AM – 9:30 AM, MON-FRI". (When the operating periods exceed the available line width, the hours and days of the week shall be stacked as shown for the R3-14a sign in Figure 2G-1.)

⁰⁶ **For preferential lanes that are in effect on a full-time basis, either the full-time Periods of Operation (R3-11b and R3-14b R3-14b, R86-4(CA) and SR60-4(CA) through SR60-6(CA)) signs shall be used, or the legends of the part-time Periods of Operations (R3-11, R3-11a, R3-14, R3-14a) signs shall be modified to display the legend 24 HOURS. The R3-11a, R3-14, R3-14a, R3-14c, R86-3(CA), R87-3(CA), and SR60-3(CA) signs shall be used for preferential lanes that are in effect on a part-time basis.**

⁰⁷ **The full-time Periods of Operation (R3-14b R3-14c, R86-4(CA) and SR60-4(CA) through SR60-6(CA)) signs shall not be used where the preferential lane is in effect only on a part-time basis.**

Option:

⁰⁸ Where additional movements are permitted from a preferential lane on an approach to an intersection, the format and words used in the legend in the middle lines on the post-mounted Periods of Operation (R3-11 series and R86(CA) series) signs and on the top line of the overhead Periods of Operation (R3-14 series and R87-3(CA)) signs may be modified to accommodate the permitted movements (such as "HOV 2+ AND RIGHT TURNS ONLY").

^{08a} **The Mandatory/Optional HOV Movement Lane Control (R94(CA)) sign may be installed on local streets when one of the mandatory turn lanes (left or right) is designated as a HOV only lane.**

⁰⁹ ~~A MOTORCYCLES ALLOWED (R3-11P) plaque may be used where motorcycles, regardless of the number of occupants, are allowed to use an HOV lane.~~

Standard:

¹⁰ ~~If used, the MOTORCYCLES ALLOWED plaque shall be mounted below a post-mounted Preferential Lane Periods of Operation (R3-11, R3-11a, or R3-11e) sign.~~

¹¹ **For all barrier- or buffer-separated or contiguous preferential lanes where access is restricted to designated locations, an overhead Periods of Operation (R3-14 series, R87-3(CA), SR60-8(CA) or SR60-9(CA)) sign shall be used at the beginning or initial entry point, and at any intermediate entry points or gaps in the barrier where vehicles are allowed to legally access the access-restricted preferential lanes. For all barrier-**

separated and buffer-separated preferential lanes, post-mounted Periods of Operation (R3-11 series, R86(CA) series and SR60-3(CA) through SR60-7(CA)) signs shall be used only as a supplement to the overhead signs at the beginning or initial entry point, or at any intermediate entry points or gaps in the barrier or buffer.

¹² For ~~buffer-separated or~~ contiguous preferential lanes where continuous access with the adjacent general-purpose lanes is provided, including those where a preferential lane is added to the roadway (see Figure 2G-2 for HOV lanes) and those where a general-purpose lane transitions into a preferential lane (see Figure 2G-3 for HOV lanes), an overhead Periods of Operation (R3-14 series or R87-3(CA)) sign shall be used at the beginning or initial entry point of the preferential lane.

Guidance:

Option:

¹³ Overhead (R3-14 series, R87-3(CA), SR60-8(CA) and SR60-9(CA)) or post-mounted (R3-11 series, R86(CA) series and SR60-3(CA) through SR60-7(CA)) Periods of Operation signs ~~should~~ **may** be installed at periodic intervals along the length of a contiguous ~~or buffer-separated~~ preferential lane where continuous access with the adjacent general-purpose lanes is provided.

Option:

¹⁴ Additional overhead (R3-14 series, R87-3(CA), SR60-8(CA) and SR60-9(CA)) or post-mounted (R3-11 series, R86(CA) series and SR60-3(CA) through SR60-7(CA)) Periods of Operation signs may be provided along the length of any type of preferential lane.

¹⁵ On conventional roads, the overhead Periods of Operation (R3-14 series, R87-3(CA), SR60-8(CA) and SR60-9(CA)) signs may be installed at the beginning or entry points and/or at intermediate points along preferential lanes in any geometric configuration.

Standard:

¹⁶ **For all types of direct access ramps that provide access to or lead to preferential lanes, a post-mounted an overhead Periods of Operation (~~R3-11 series~~ R87-4(CA) or R87-5(CA)) sign shall be used at the beginning or initial entry point of the direct access ramp.**

Option:

~~¹⁷ For direct access ramps to preferential lanes, an overhead Periods of Operation (R3-14 series) sign may be used at the beginning or initial entry point to supplement the required post-mounted signs.~~

¹⁸ Lane-use control signals (see Chapter 4M) may be used at access points to preferential lanes to indicate that a ramp or access roadway leading to the preferential lane or facility, or one or more specific lanes of the facility, are open or closed (see Figure 2G-14).

Section 2G.06 Preferential Lane Advance Regulatory Signs (R3-12, R3-12e, R3-12f, R3-15, R3-15a, and R3-15d)

Guidance:

Standard:

⁰¹ **The Preferential Lane Advance (R3-12, R3-12f, R3-15, and R3-15d, SR60-1(CA) and SR60-2(CA)) signs ~~should~~ shall be used for advance notification of a ~~barrier-separated, buffer-separated, or~~ contiguous preferential lane that is added to the general-purpose lanes **and continuous access with the adjacent general-purpose lanes is provided** (see Figure ~~2G-12~~ 2G-2).**

⁰² **The Preferential Lane Advance (R3-12e and R3-15a) signs ~~should~~ shall be used for advance notification of a general-purpose lane that becomes a preferential lane **and continuous access with the adjacent general-purpose lanes is provided** (see Figure ~~2G-13~~ 2G-3).**

Option:

⁰³ The legends on the R3-12f and R3-15d signs may be modified to suit the type of preferential lane.

Guidance:

⁰⁴ *On conventional roads, for general-purpose lanes that become preferential lanes, a post-mounted (R3-12e) or overhead (R3-15a) Preferential Lane Advance sign should be installed in advance of the beginning of or initial entry point to the preferential lane at a distance determined by engineering judgment based on speed, traffic*

characteristics, and other site-specific considerations. The distance selected should provide adequate opportunity for ineligible vehicles to vacate the lane prior to the beginning of the restriction.

⁰⁵ On freeways and expressways, for general-purpose lanes that become preferential lanes, an overhead Preferential Lane Advance (R3-15a) sign should be installed at least 1 mile in advance of the beginning of the preferential lane restriction.

Option:

⁰⁶ Additional post-mounted or overhead Preferential Lane Advance signs may be placed farther in advance of or closer to the beginning or initial entry points to a preferential lane.

Standard:

⁰⁷ **A Specific Hours/Days (R82A(CA) or R82B(CA)) Plaque shall be used to designate the periods of operation for preferential lanes that operate on a part-time basis.**

Guidance:

⁰⁸ *The Specific Hours/Days plaque, when used, should be placed below the R3-12, R3-12e, R3-12f, SR60-1(CA), and SR60-2(CA) signs.*

Section 2G.07 Preferential Lane Ends Regulatory Signs (R3-12a, R3-12b, R3-12c, R3-12d, R3-12g, R3-12h, R3-15b, R3-15c, and R3-15e)

Standard:

⁰¹ **A post-mounted Preferential Lane Ends (R3-12b or R3-12h) sign shall be installed at least 1/2 mile in advance of the termination of a preferential lane.**

⁰² **Except as provided in Paragraph 6, a post-mounted Preferential Lane Ends (R3-12a or R3-12g or SR60-7(CA)) sign shall be installed at the point where a preferential lane and restriction end and traffic must merge into the general-purpose lanes.**

⁰³ **A post-mounted Preferential Lane Ends (R3-12d) sign shall be installed at least 1/2 mile in advance of the point where a preferential lane restriction ends and the lane becomes a general-purpose lane.**

⁰⁴ **Except as provided in Paragraph 7, a post-mounted Preferential Lane Ends (R3-12c) sign shall be installed at the point where a preferential lane restriction ends and the lane becomes a general-purpose lane.**

Option:

⁰⁵ The legends on the R3-12g and R3-15e signs may be modified to suit the type of preferential lane.

⁰⁶ An overhead Preferential Lane Ends (R3-15b or R3-15e) sign may be installed instead of or in addition to a post-mounted R3-12a or R3-12g sign at the point where a preferential lane and restriction ends and traffic must merge into the general-purpose lanes.

⁰⁷ An overhead Preferential Lane Ends (R3-15c) sign may be installed instead of or in addition to a post-mounted R3-12c sign at the point where the preferential lane restriction ends and the lane becomes a general-purpose lane.

Section 2G.08 Warning Signs on Median Barriers for Preferential Lanes

Option:

⁰¹ When a warning sign applicable only to a preferential lane is installed on a median barrier with limited lateral clearance to the adjacent travel lanes or shoulders, the warning sign may have a vertical rectangular shape. For a High Occupancy Vehicle lane, such signs may be used instead of using the HOV Plaque (W16-11P) (see Section 2G.09) with a standard diamond-shaped warning sign.

Standard:

⁰² **When a vertical rectangular-shaped warning sign applicable only to a preferential lane is installed on a median barrier, the top portion of the sign shall be comprised of a white symbol or legend denoting the type of preferential lane (such as the diamond symbol for HOV or the legend BUS LANE) on a black background with a white border, and the bottom portion of the sign shall be comprised of the standard word message or symbol of the standard warning sign as a black legend on a yellow background with a black border (see Figure 2G-4).**

Guidance:

03 Where lateral clearance is limited, such as when a post-mounted warning sign applicable only to a preferential lane is installed on a median barrier, the edges of the sign should not project beyond the outer edges of the barrier.

Option:

04 Where lateral clearance is limited, warning signs applicable only to a preferential lane that are post-mounted on a median barrier and that are 72 inches or less in width may be skewed up to 45 degrees in order to fit within the barrier width or may be mounted higher, such that the vertical clearance to bottom of the sign, light fixture, or its structural support, whichever is lowest, is not less than 14 feet above any portion of the pavement and shoulders.

Standard:

05 Where lateral clearance is limited, Preferential Lane warning signs that are post-mounted on a median barrier and that are wider than 72 inches shall be mounted with a vertical clearance that complies with the provisions of Section 2A.18 for overhead mounting.

Guidance:

06 The HOV Lane Reduction (W11-1(CA)) sign (see Figure 2G-4(CA)) should be used to warn of a reduction in the number of HOV lanes.

07 The HOV Merge (W59-1(CA)) sign (see Figure 2G-4(CA)) should be used in advance of locations where HOV lanes converge. This includes HOV direct access ramps where high speeds and volumes prevail and merging or weaving must be accomplished in a relatively short distance.

08 The HOV Advisory Exit (Ramp) Speed (W72B(CA)) sign when used, should be placed on the left of an HOV drop ramp or freeway to freeway connector to advise motorists of the speed at which the drop ramp or freeway to freeway connector can be comfortably negotiated.

09 The HOV THRU TRAFFIC MERGE LEFT (RIGHT) (W74-1(CA)) sign (see Figure 2G-4(CA)) should be used to inform motorists that the outside or inside lane of an HOV facility with two or more directional HOV lanes is being dropped at the next exit and through HOV traffic must merge into the adjacent HOV lane. This sign should not be used for a lane reduction.

Option

10 The HOV Lane Selection SW54(CA) and SW54-1(CA) signs (see Figure 2G-4(CA)) may be used as an advance warning that motorists will have to choose whether or not to be in an HOV lane. These signs may be used where geometrics make entrapment likely or where there is a history of vehicles being entrapped in an HOV lane.

Guidance:

11 The SW54(CA) and SW54-1(CA) signs should not be used at the entrance of an HOV lane.

12 The SW54C(CA) sign (see Figure 2G-4(CA)) should be used in conjunction with the Lane Selection sign so that motorists can determine if they are eligible to use the HOV lane.

Section 2G.09 High-Occupancy Vehicle (HOV) Plaque (W16-11P)

Option:

01 In situations where there is a need to warn drivers in an HOV lane of a specific condition, a HOV (W16-11P) plaque (see Figure 2G-4) may be used above a warning sign. The HOV plaque may be used to differentiate a warning sign specific for HOV lanes when the sign is also visible to traffic on the adjacent general-purpose roadway. Among the warning signs that may be possible applications of the HOV plaque are the Advisory Exit Speed, Added Lane, and Merge signs.

02 The diamond symbol may be used instead of the word message HOV on the W16-11P plaque. When appropriate, the words LANE or ONLY may be used on this plaque.

Support:

03 Section 2G.08 contains information regarding warning signs that can be mounted on barriers for HOV or other types of preferential lanes.

Section 2G.10 Preferential Lane Guide Signs – General

Support:

01 Preferential lanes are used on freeways, expressways, and conventional roads. Except as otherwise provided, Sections 2G.10 through 2G.15 apply only to guide signs for preferential lanes on freeways and expressways.

Guidance:

02 On conventional roads, guide signs applicable only to preferential lanes are ordinarily not needed, but if used they should comply with the provisions for guide signs in Chapter 2D and any principles for Preferential Lane guide signs in Sections 2G.10 through 2G.15 that engineering judgment finds to be appropriate for the conditions.

Support:

03 Consistency in signs and pavement markings for preferential lanes plays a critical role in building public awareness, understanding, and acceptance, and makes enforcement more effective.

04 Additional guidance and standards related to the designation, operational considerations, signs, pavement markings, and other considerations for preferential lanes is provided in Sections 2G.03 through 2G.07, and 2G.09, and Chapter 3D.

Guidance:

05 The appropriate combinations of pavement markings and standard overhead and post-mounted regulatory, warning, and guide signs for a specific preferential lane application should be selected based on an engineering study.

06 If overhead signs applicable only to a preferential lane are located in approximately the same longitudinal position along the highway as overhead signs applicable only to the general-purpose lanes, the signs for the preferential lane should be separated laterally from the signs for the general-purpose lanes to the maximum extent practical to minimize conflicting information.

07 The Preferential Lane signs should be designed and located to avoid overloading the road user. Based on the importance of the sign, regulatory signs should be given priority over guide signs. The order of priority of guide signs should be Advance Guide, Preferential Lane Entrance Direction, and finally Preferential Lane Exit Destination supplemental guide signs.

Standard:

08 Signs applicable only to a preferential lane shall be distinguished from signs applicable to general-purpose lanes by the inclusion of the applicable symbol(s) and/or word(s).

Support:

09 The symbol and/or word message that appears on a particular guide sign applicable only to a preferential lane will vary based on the specific type of allowed traffic and on other related operational constraints that have been established for a particular lane, such as an HOV lane, a bus lane, or a taxi lane.

Standard:

10 For HOV lanes, the diamond symbol shall appear on each Advance Guide sign, Preferential Lane Entrance Direction sign, and Preferential Lane Entrance Gore sign, as shown in Figures 2G-5 through 2G-7 for the designated entry and exit points for barrier- and buffer-separated geometric configurations and direct access ramps to or from such lanes. The diamond symbol shall not be used with preferential lanes for other types of traffic, such as bus lanes or taxi lanes.

11 Signing for an HOV lane that is managed by means of varying the occupancy requirement in response to changing conditions shall also comply with these provisions.

12 The diamond symbol shall be displayed in the legend of each Preferential Lane guide sign at the designated entry and exit points for all types of HOV lanes (including barrier- and buffer-separated, contiguous, and direct access ramps) in order to alert motorists that there is a minimum allowable vehicle occupancy requirement for vehicles to use the HOV lanes. Guide signs shall not display the occupancy requirement for the preferential lane.

13 A combination of guide and regulatory signs shall be used in advance of and at the initial entry point and all intermediate entry points from general-purpose lanes or facilities to contiguous, barrier-separated, and buffer-separated preferential lanes where access between the preferential and general-purpose lanes is restricted to designated locations. The regulatory signs shall comply with the provisions of Sections 2G.03 through 2G.07.

14 Regulatory signs alone shall be used in advance of, at the beginning of, and at periodic intervals along contiguous or buffer-separated preferential lanes that provide continuous access between the adjacent general-purpose lanes and the preferential lane (see Figures 2G-12 and 2G-13). The design and placement of the regulatory signs shall comply with the provisions of Sections 2G.03 through 2G.07.

15 Except as otherwise provided in Sections 2G.10 through 2G.13, guide signs applicable to a preferential lane with a vehicle occupancy requirement shall be distinguished from those applicable to general-purpose lanes by displaying the white diamond symbol on a black background at the left-hand edge of these signs.
Option:

16 When post-mounted guide signs applicable only to a preferential lane are installed on a median barrier with limited lateral clearance to the adjacent travel lanes or shoulders, the guide signs may have a vertical rectangular shape.

Standard:

17 When vertical rectangular shaped guide signs applicable only to a preferential lane are installed on a median barrier, the top portion of the signs shall be comprised of the applicable white symbol or white word message that identifies the type of preferential lane (such as the diamond symbol for an HOV lane) on a black background with a white border, and the bottom portion of the sign shall be comprised of the appropriate guide sign legend on a green background with a white border (see Figures 2G-3, 2G-6, and 2G-7).

Guidance:

18 *Where lateral clearance is limited, such as when a post-mounted Preferential Lane guide sign is installed on a median barrier, the edges of the sign should not project beyond the outer edges of the barrier.*

Option:

19 Where lateral clearance is limited, Preferential Lane guide signs that are 72 inches or less in width may be skewed up to 45 degrees in order to fit within the barrier width or may be mounted higher, such that the vertical clearance to the bottom of the sign, light fixture, or its structural support, whichever is lowest, is not less than 14 feet above any portion of the pavement and shoulders.

Standard:

20 Where lateral clearance is limited, Preferential Lane guide signs that are post-mounted on a median barrier and that are wider than 72 inches shall be mounted with a vertical clearance that complies with the provisions of Section 2A.18 for overhead mounting.

Option:

21 Lane-use control signals (see Chapter 4M) may be used at access points to preferential lanes to indicate that a ramp or access roadway leading to or from the preferential lane or facility, or one or more specific lanes of the facility, are open or closed.

22 Changeable message signs may supplement, substitute for, or be incorporated into static guide signs where travel conditions change or where multiple types of operational strategies (such as variable occupancy requirements, vehicle types, or pricing policies) are used and varied throughout the day or week to manage the use of, control of, or access to preferential lanes.

Standard:

23 When changeable message signs (see Chapter 2L) are used as guide signs for preferential lanes, they shall be the required sign size and shall display the required letter height and legend format that corresponds to the type of roadway facility and design speed.

24 Advance Guide signs, Preferential Lane Entrance Direction signs, and Preferential Lane Entrance Gore signs for the initial entry point and intermediate entry points into a preferential lane from the general-purpose lanes on the same designated route shall not identify the entry point as an exit by using the word "EXIT" on the sign or on a plaque.

Guidance:

25 *Advance Guide signs and Preferential Lane Entrance Direction signs for initial and intermediate entry points into a preferential lane should use the word "ENTRANCE," such as "HOV LANE ENTRANCE" (see Figures 2G-5 and 2G-6) to convey the fact that vehicles are not leaving the designated route.*

26 *Preferential Lane Entrance Gore signs (see Figure 2G-7) at the initial entry point to a preferential lane should use the word "ENTRANCE." Preferential Lane Entrance Gore signs at intermediate entry points to a barrier-separated preferential lane where the sign would be located immediately adjacent to and directly viewed by traffic in the preferential lane should not use the word "ENTRANCE."*

Standard:

27 When the entry point is on the left-hand side of the general-purpose lanes, a LEFT (E1-5aP) plaque (see Figure 2E-22) shall be ~~added to~~ placed above and abutting the top left edge of the Advance Guide and Preferential Lane Entrance Direction signs. The LEFT plaque shall not be used on a preferential lane regulatory sign.

Section 2G.11 Guide Signs for Initial Entry Points to Preferential Lanes

Standard:

01 Except where a ~~buffer-separated or~~ contiguous preferential lane is added or where a general-purpose lane becomes a ~~buffer-separated or~~ contiguous preferential lane, and provides continuous access with the adjacent general-purpose lanes as illustrated in Figures 2G-2 and 2G-3, an Advance Guide sign shall be provided at least 1/2 mile prior to the initial entry point to all types of preferential lanes in any type of geometric configuration. A Preferential Lane Entrance Direction sign shall also be provided at the initial entry point. Advance Guide and Preferential Lane Entrance Direction signs for such entry points shall not include the word "EXIT" (see Section 2G.10).

Guidance:

Option:

02 An Advance Guide sign ~~should~~ may also be installed and located approximately 1 mile in advance of the initial entry point to a preferential lane that restricts access with the adjacent general-purpose lanes to designated locations.

Option:

03 An Advance Guide sign may also be installed and located approximately 2 miles in advance of the initial entry point to a preferential lane that restricts access with the adjacent general-purpose lanes to designated locations.

Standard:

04 For barrier-separated, buffer-separated, or contiguous preferential lanes where entry is restricted to only designated points, the Advance Guide and Preferential Lane Entrance Direction signs shall be mounted overhead.

Guidance:

Option:

05 Preferential Lane Exit Destination guide signs, identifying final destination and downstream exit locations accessible from the preferential lane (see Figures 2G-8, ~~2G-13~~, 2G-14, and 2G-16), ~~should~~ may be installed in advance of the initial entry points to access-restricted preferential lanes (such as barrier- and buffer-separated).

Guidance:

These Preferential Lane Exit Destination guide signs should be located based on the priority of the message, the available space, the existing signs on adjacent general-purpose traffic lanes, roadway and traffic characteristics, the proximity to existing overhead signs, the ability to install overhead signs, and other unique local factors.

Standard:

06 Advance destination guide signs for preferential lanes shall include an upper section displaying a black legend that includes the type of preferential lane and the word "EXITS," such as "HOV EXITS," on a white background. For preferential lanes that incorporate a vehicle occupancy requirement, the white diamond symbol on a black background shall be displayed at the left edge of this upper section (see Figure 2G-8). Advance destination guide signs for preferential lanes shall only list direct exits from the preferential lane to another highway.

Support:

07 Figure 2G-8 shows an example of signs for the initial entry point to a preferential lane.

Section 2G.12 Guide Signs for Intermediate Entry Points to Preferential Lanes

Standard:

01 For barrier-separated, buffer-separated, and contiguous preferential lanes where entry is restricted only to designated points, an overhead Preferential Lane Entrance Direction sign shall be provided at intermediate entry points to the preferential lane from the general-purpose lanes.

Guidance:

02 For barrier- and buffer-separated preferential lanes where intermediate entry from the general-purpose lanes is provided via a separate lane or ramp (see Figure 2G-9), at least one Advance Guide sign should be provided in addition to the Preferential Lane Entrance Direction sign.

03 For access-restricted preferential lanes where intermediate entrance and egress are at the same designated access location, the Preferential Lane Entrance Direction sign should be located between 1/2 and 1/4 of the length of the designated entry area, as measured from the downstream end of the entry area (see Figure 2G-10).

Standard:

04 The Advance Guide signs, if used for intermediate entry points to a preferential lane from the general purpose lanes, shall be overhead.

Option:

05 Advance Guide signs may be provided at approximately 1/2 mile, 1 mile, and 2 miles in advance of intermediate entry points from the general-purpose lanes to a preferential lane.

Standard:

06 Advance Guide and Preferential Lane Entrance Direction signs for intermediate entry points shall not include the word "EXIT" (see Section 2G.10).

Guidance:

Option:

07 Exit Destination guide signs, identifying the final destination and downstream exit locations accessible from the preferential lane, ~~should~~ **may** be installed in advance of intermediate entry points from the general-purpose lanes to access-restricted preferential lanes.

Support:

08 Section 2G.11 contains information on the design and placement of Preferential Lane Exit Destination guide signs.

09 Figures 2G-9 and 2G-10 show examples of signs for various geometric configurations of intermediate entry to a barrier- or buffer-separated preferential lane where access is restricted to designated locations.

Section 2G.13 Guide Signs for Egress from Preferential Lanes to General-Purpose Lanes

Standard:

01 For barrier-separated, buffer-separated, and contiguous preferential lanes where egress is restricted only to designated points, post-mounted Advance Guide and post-mounted Intermediate Egress Direction signs (see Figure 2G-11) shall be installed in the median or on median barriers that separate two directions of traffic prior to and at the intermediate exit points from the preferential lanes to the general-purpose lanes (see Figure 2G-9).

02 The legends of these signs shall refer to the next exit or exits from the general-purpose lanes by displaying the appropriate destination information, exit number(s), or both. The Intermediate Egress Direction signs for egress from the preferential lanes to the general-purpose lanes shall not refer to the egress as an exit.

Support:

03 Section 2G.10 contains information on the design of post-mounted guide signs applicable to a preferential lane when installed on a median barrier. Figures 2G-9 and 2G-12 show examples of signs for various geometric configurations of intermediate egress from a barrier- or buffer-separated preferential lane where access is restricted to designated locations.

Guidance:

04 Where two or more adjacent preferential lanes are present in a single direction, consideration should be given to the use of overhead guide signs to display the information related to egress from the preferential lanes.

05 For barrier-separated and buffer-separated preferential lanes where egress from a preferential lane to the general-purpose lanes is restricted only to designated points via a separate lane or ramp, the Advance Guide and Intermediate Egress Direction signs for the egress should be mounted overhead and a Pull-Through sign should be mounted with the Intermediate Egress Direction sign (see Figure 2G-12).

Standard:

06 For preferential lanes that incorporate a vehicle occupancy requirement, the design of the overhead Advance Guide and Egress Direction signs for intermediate egress from the preferential lanes to the general-purpose lanes shall display a white diamond symbol on a black background at the left-hand edge of the signs.

07 The design of Pull-Through signs when used in conjunction with an Egress Direction sign at an intermediate egress from the preferential lanes to the general-purpose lanes shall be distinguished from those applicable to general-purpose lanes by inclusion of an upper section with the applicable black legend on a white background, such as HOV LANE. For preferential lanes that incorporate a vehicle occupancy requirement, the white diamond symbol on a black background shall be displayed at the left-hand edge of this upper section.

Section 2G.14 Guide Signs for Direct Entrances to Preferential Lanes from Another Highway

Standard:

01 For direct access ramps to preferential lanes from a transit facility (such as a park - ride lot or a transit station or terminal) that is accessible from surface streets, advance guide signs shall be provided along the adjoining surface streets to direct traffic into and through the transit facility to the preferential lane (see [Figure 2G-13](#)).

01a The HOV Advance Lane Assignment (G20-9(CA)) sign (see [Figure 2G-6\(CA\)](#)) shall be used on a multilane cross street approaching a direct access ramp to an HOV lane to direct traffic into the proper lane to access the ramp.

01b The HOV LANE ENTRANCE (G92-1(CA)) sign (see [Figure 2G-6\(CA\)](#)) shall be used at the entrance to a direct access ramp to an HOV lane. The G92-1(CA) sign is similar to the FREEWAY ENTRANCE (D13-3) sign and shall be installed similarly. Refer to [Section 2A18](#) and [2B.41](#).

Support:

02 ~~Figure 2G-14~~ [2G-13](#) provides examples of recommended uses and layouts of signs for HOV lanes for direct access ramps, park - ride lots, and access from surface streets.

Section 2G.15 Guide Signs for Direct Exits from Preferential Lanes to Another Highway

Standard:

01 For contiguous preferential lanes on the left-hand side of the roadway, Advance Guide signs, Exit Direction signs, and Exit Gore signs (see [Figure 2G-14](#) and [Figure 2G-14\(CA\)](#)) specifically applicable to the preferential lanes shall be used for exits to direct access ramps, such as HOV lane ramps (see [Figure 2G-15](#) [2G-15\(CA\)](#)) or ramps to park - ride facilities.

02 The design of Advance Guide, Exit Direction, and Pull-Through signs for direct exits from preferential lanes shall be distinguished from those applicable to general-purpose lanes by inclusion of an upper section with the applicable black legend on a white background, such as HOV LANE (for Pull-Through signs) or HOV EXIT (for Advance Guide and Exit Direction signs). For preferential lanes that incorporate a vehicle occupancy requirement, the white diamond symbol on a black background shall be displayed at the left-hand edge of this upper section (see [Figures 2G-15](#) [2G-15\(CA\)](#) and [2G-16](#)).

02a The HOV Supplemental Destination (G86-15(CA)) and HOV Advance Guide (G83-6(CA)) signs shall be used for Advance Guide signs for exits to direct access ramps from an HOV lane.

02b The HOV Exit Direction (G85-12(CA)) sign shall be used as the Exit Direction sign for exits to direct access ramps from an HOV lane.

Option:

02c If an auxiliary lane is not used in advance of the direct access ramp, the G83-6(CA) sign and the W61C(CA) panel on the G85-12(CA) sign may be eliminated.

Standard:

02d The HOV Exit with Arrow (E8-4) sign shall be used as the Exit Gore sign for exits to direct access ramps from an HOV lane.

Guidance:

02e The arrow on the E8-4 sign should be aligned to approximately the angle of departure and should be positioned to avoid confusion that the exit may serve general purpose traffic.

03 Advance Guide ~~and Exit Direction~~ signs for exits to direct access ramps from a preferential lane should be mounted overhead. A Pull-Through sign should be used with the Exit Direction sign at exits to direct access ramps.

Standard:

03a Exit Direction signs for exits to direct access ramps from a preferential lane shall be mounted overhead.

04 Post-mounted guide signs in a vertical rectangular shape installed on a median barrier shall not be used for the ~~Advance Guide and Exit Direction~~ signs for exits to direct access ramps.

05 Because direct access ramps for preferential lanes at interchanges connecting two freeways are typically left-hand side exits and typically have design speeds similar to the preferential lane, overhead Advance Guide signs and overhead Exit Direction signs shall be provided in advance of and at the entry point to each freeway-to-freeway preferential lane ramp (see Figure 2G-16).

Guidance:

06 The use of guide signs for preferential lanes at freeway interchanges should comply with the provisions for guide signs established in this Manual.

Support:

07 Guide signs for direct access ramps for preferential lanes at interchanges connecting two freeways are similar to those for a connecting ramp between two freeway facilities.

Section 2G.16 Signs for Priced Managed Lanes – General

Support:

01 A priced managed lane is a managed lane that employs tolling or pricing, typically through electronic toll collection, to manage congestion levels and maintain a certain level of service for users of the facility. A priced managed facility typically provides a less congested alternative to adjacent lanes along the same designated route, or to a nearby facility, that experience recurring congestion during peak periods. A priced managed lane might allow non-toll travel by certain vehicles based on occupancy or other criteria. A variety of operational management strategies might be used in conjunction with tolling or pricing.

02 The number and combination of operational strategies that are applied to a managed lane to manage congestion or improve efficiency might be practically limited by the amount of information that can be legibly displayed on signs or in signing sequences and still be readily comprehended by road users. Such factors to consider when evaluating alternatives for managed lanes are locations of signs for general-purpose interchanges and for other roadway conditions, the number of intermediate access points between the managed and general-purpose lanes and the need to repeat the operational information, and the distance over which a signing sequence that displays all of the eligibility requirements can be displayed.

03 Because managed lanes have the capability to employ a variety of operational strategies on a changing basis, it is not practical to assign a naming convention to such lanes for the purpose of signing based on the specific operational management strategies, as is more readily accomplished with other types of preferential lanes, such as HOV, Bus, or Bike lanes. Instead, the various requirements, restrictions, and eligibility criteria are more appropriately conveyed through a sequence of regulatory and guide signs with a more encompassing designation for the purpose of providing directional information.

04 As priced managed lanes become more prevalent as an operational strategy, it will be important to establish a uniform naming convention to distinguish those lanes that are an alternative to travel on adjacent general-purpose lanes on the same designated route to effectively communicate to motorists the range of basic requirements for similar facilities in different regions.

Standard:

05 Priced managed lanes that are adjacent to general-purpose lanes along the same designated route shall be signed using the legend EXPRESS or EXPRESS LANE(S). This provision shall apply when any of the following operational strategies is used for a managed lane:

A. All users of the managed lane are charged a fixed or variable toll;

B. General-purpose traffic using the managed lane is charged a fixed or variable toll, but HOV traffic is allowed to travel without being charged a toll on either a full- or part-time basis;

- C. General-purpose traffic using the managed lane is charged a fixed or variable toll, but HOV traffic is offered a discounted toll on either a full- or part-time basis; or**
- D. General-purpose traffic using the managed lane is charged a fixed or variable toll, but HOV traffic registered with a local program travels at a discounted toll or without being charged a toll on either a full- or part-time basis (a transponder or other identifier is typically required of HOVs to indicate registration in conjunction with electronic or visual enforcement and verification of vehicle occupancy).**

⁰⁶ **The legends EXPRESS and EXPRESS LANE(S) shall not be used on signs for entrances to highways on which all lanes are managed and there are no adjacent general-purpose lanes on the same designated route. The legends EXPRESS and EXPRESS LANE(S) shall not be used on signs for a managed ramp connection that provides an alternative to a general-purpose ramp connection (see Figure 2F-7), except where the ramp leads directly to a managed lane as described in Section 2G.14. The legends EXPRESS and EXPRESS LANE(S) shall not be used on signs for open-road tolling lanes that bypass a conventional toll plaza (see Chapter 2F).**

⁰⁷ **The diamond symbol shall be reserved exclusively for preferential lanes whose operational strategy is occupancy-based only (see Sections 2G.03 through 2G.14) and shall not be used to designate a managed lane in which other operational strategies, such as tolling and pricing, are employed to allow general-purpose traffic to use the lane.**

Section 2G.17 Regulatory Signs for Priced Managed Lanes

Standard:

⁰¹ **Except as otherwise provided in this Section, the provisions of Sections 2G.03 through 2G.07 regarding regulatory signs for Preferential lanes shall apply to priced managed lanes operated at all times or at certain times with a toll payment requirement of some or all vehicles to use the lane(s). Such managed lanes shall use changeable message signs or changeable message elements within static signs to display the appropriate regulatory sign messages only when they are in effect.**

⁰² **Regulatory signs for preferential lanes shall be appropriately modified for adaptation to a priced managed lane, where applicable, as shown in Figure 2G-17.**

⁰³ **Regulatory signs shall be used to indicate the toll charged. If the toll varies, regulatory signs that include changeable message elements, such as the R3-48 and R3-48a signs that are shown in Figure 2G-17, shall be used to display the actual toll amount in effect at any given time.**

⁰⁴ **When only vehicles with a registered ETC account are allowed to use a managed lane where some or all vehicles are charged a toll, regulatory signs to indicate such a restriction shall be provided and shall incorporate the pictograph adopted by the toll facility's ETC payment system and the word ONLY (see Section 2G.18 for the incorporation of such regulatory legends into the guide signs for the entrances to such facilities). The display of the ETC system pictograph shall comply with the provisions of Sections 2F.03 and 2F.04 as shown in Figures 2G-17 and 2G-18.**

⁰⁵ **When HOV traffic is allowed to use a priced managed lane without paying a toll and registration in a local program is not required to receive the toll exemption, the Vehicle Occupancy Definition (R3-10 (R93-2(CA)) or R3-13) signs (see Section 2G.04) shall be modified to delete the diamond symbol to create priced managed lane Vehicle Occupancy Definition (R3-40 and R3-43) signs to indicate the minimum occupancy related to the management strategy (see Figure 2G-17).**

⁰⁶ **A priced managed lane Periods of Operation (R3-44 or R3-44a) sign (see Figure 2G-17) shall be installed at the beginning or initial entry point, and at any intermediate entry points where vehicles are allowed to legally enter an access-restricted priced managed lane.**

⁰⁷ **When the vehicle occupancy required for non-toll use of a managed lane is varied as a part of a priced managed lane operational strategy, regulatory signs that include changeable message elements shall be used to display the required vehicle occupancy in effect for non-toll travel.**

Option:

⁰⁸ Where registration in a local program or ETC account is required for HOV traffic to travel in a priced managed lane without being charged a toll or by being charged a discounted toll, such information may be displayed on a separate sign within the sequence of the required regulatory and guide signs.

Guidance:

^{08a} *No more than two destinations should be shown on the R3-48 or R3-48a sign. If multiple destinations are used, one of these destinations should be the furthest destination on the facility; the other destination(s) should be an intermediate interchange. The particular intermediate interchange to be shown on the R3-48 or R3-48a sign should be determined on a case-by-case basis, depending upon local factors including the relative importance of the intermediate interchanges.*

Standard:

⁰⁹ **R3-42 Series and R3-45 Series signs (see Figure 2G-17) shall be installed in accordance with the provisions of Section 2G.07 to indicate the termination of a priced managed lane or restriction. The R3-42, R3-42a, and R3-45 signs shall be used only where the managed lane and restriction end and traffic must merge into the general-purpose lanes. The R3-42b, R3-42c, and R3-45a signs shall be used only where the managed lane restriction ends and the lane becomes a general-purpose lane.**

Section 2G.18 Guide Signs for Priced Managed Lanes

Standard:

⁰¹ **Except as otherwise provided in this Section, guide signs for barrier-separated, buffer-separated, and contiguous managed lanes shall follow the specific provisions for Preferential Lane guide signs contained in Sections 2G.10 through 2G.15. Except as otherwise provided in this Section, guide signs for highways on which all lanes are managed shall follow the general provisions for freeway and expressway guide signs as contained in Chapter 2E as a whole. Guide signs for highways on which all lanes are managed and tolling or pricing is used as a management strategy shall follow the applicable provisions for toll road guide signs as contained in Chapter 2F, in addition to the general provisions of Chapter 2E.**

⁰² **If fixed or variable tolls are used as an operational strategy for a managed lane, the guide signs shall comply with the provisions of Sections 2F.03, 2F.04, and 2F.17 regarding the use, size, and placement of ETC-account pictographs.**

Support:

⁰³ Figure 2G-18 shows examples of Guide signs for entrances to priced managed lanes and other ETC account-only toll facilities that incorporate header panels with ETC account pictographs and regulatory legends.

Guidance:

Option:

⁰⁴ Exit Destination supplemental guide signs, identifying final destination and downstream exit locations accessible from the managed lane (see Figure 2G-19), ~~should~~ **may** be installed in advance of the initial entry points to priced managed lanes. ~~These signs should be located in accordance with the provisions of Paragraph 5 of Section 2G.11.~~

Guidance:

^{04a} *Exit Destination supplemental guide signs should be located in accordance with the provisions of Paragraphs 5 and 6 of Section 2G.11.*

Option:

⁰⁵ For managed lanes that are available as an alternative to travel on adjacent general-purpose lanes on the same designated route, changeable message signs indicating the comparative travel times or congestion levels using the managed lanes versus the general-purpose lanes (see Figure 2G-20) ~~should~~ **may** be installed in advance of the initial and intermediate entry points to the managed lanes.

Option:

⁰⁶ Changeable message signs may also be used on non-managed highways to display comparative travel times or congestion levels for a nearby managed highway.

Standard:

⁰⁷ **Guide signs at the initial and intermediate entry points to a priced managed lane in which all general-purpose passenger vehicles are allowed shall include the legend EXPRESS or EXPRESS LANE(S). The guide signs shall incorporate the pictograph of the ETC account system into a header panel within the**

guide sign in accordance with Sections 2F.03, 2F.04, and 2F.17. For a priced managed lane that allows non-toll travel by HOV traffic without registration in a local program, the header panel shall be modified to a regulatory format to display both the pictograph of the ETC account system and the minimum occupancy requirement for non-toll travel with a black legend on a white background (see Figure 2G-19).

08 Guide signs at the initial and intermediate entry points to a managed lane that allows only HOV traffic with either a fixed or variable occupancy requirement shall follow the provisions of Sections 2G.10 through 2G.12 and 2G.14.

Support:

09 Figures 2G-21 through 2G-24 show examples of guide signs for various configurations of initial and intermediate entrances to a priced managed lane.

Standard:

10 The use and locations of guide signs for intermediate egress locations and direct exits from a priced managed lane (see Figures 2G-24 through 2G-27) shall comply with the provisions of Sections 2G.13 and 2G.15. The signs shall be suitably modified to display header messages of white legend on a green background that relate the guide sign legends to the managed lane(s) as appropriate in accordance with the following:

- A. Post-mounted or overhead-mounted Advance Guide signs for intermediate egress to the general-purpose lanes shall include the legend LOCAL EXITS in a header panel within the guide signs, destination information or the exit number(s) for the next exit(s) accessible from the general-purpose lanes, and the appropriate distance information to the location of the egress (see Figures 2G-24 and 2G-25).**
- B. Post-mounted or overhead-mounted Intermediate Egress Direction signs shall include the legend LOCAL EXITS in a header panel within the signs, the destination information or the exit number(s) of the next exit(s) accessible from the general-purpose lanes, and a diagonally upward-pointing directional arrow (see Figures 2G-24 and 2G-25).**
- C. For direct exits to another roadway, the legend EXPRESS EXIT shall be used on the Advance Guide and Exit Direction signs (see Figure 2G-26).**
- D. For pull-through signs, the legend EXPRESS LANE(S) shall be used, either as a header panel within the pull-through sign or as the principal legend of the sign without a header panel (see Figures 2G-25, 2G-26, and 2G-27).**

Support:

11 Section 2G.13 contains information on the use of overhead-mounted guide signs for intermediate egress to the general-purpose lanes.

12 Figures 2G-28 and 2G-29 show examples of guide signing for direct entrances to a priced managed lane from a crossroad or surface street.

Standard:

12a The G92-1(CA) sign shall be used for direct entrances to a priced managed lane from a crossroad or surface street. When used for this purpose the sign shall be modified in accordance with the provisions of this section.

Section 2G.101(CA) Preferential Lane Enforcement Signing (SR50(CA)) series

Guidance:

01 The HOV VIOLATION \$__ MINIMUM FINE (SR50-2(CA)) sign should be placed near the beginning of all HOV facilities and may be placed at intermediate entry point or gaps in the barrier or buffer for all barrier- or buffer-separated HOV lanes.

02 The SR50-2(CA) sign should also be used on priced managed lane facilities that charge HOV users no toll or a discounted toll.

Option:

03 The SR50-2(CA) sign may be repeated at 2-mile intervals or as needed at locations experiencing high violation rates.

04 The HOV VIOLATION \$__ MINIMUM FINE (SR50-1(CA)) sign may be used to supplement the SR50-2(CA) sign on HOV facilities or priced managed lane facilities where violation rates are particularly high.

Support:

05 The SR50-1(CA) is normally placed onto an existing overhead sign structure if it can adequately support the additional sign.

Standard:

- 06 **These signs shall be modified to delete the diamond symbol when utilized on priced managed lanes.**

Section 2G.102(CA) Regulatory Signs for Preferential Lanes at Metered On-Ramps

Support:

01 For State highways, see Caltrans' Ramp Metering Design Manual. See Section 1A.11 for information regarding this publication.

02 Refer to CVC 21655.5 for Exclusive- or Preferential-Use Lanes for High Occupancy Vehicles.

03 Refer to Section 2B.56 for additional regulatory signs to be used at metered on-ramps.

Guidance:

04 *The No Left Turn Specific Hours EXCEPT BUSES AND HOV __+(R33B(CA)) sign should be installed on local streets (with concurrence of local agency) whenever left turns are restricted to buses and high-occupancy vehicles only during peak hours. The No Left Turn WHEN METERED EXCEPT BUSES AND HOV __+ (R33C(CA)) sign should be installed on local streets (with concurrence of local agency) whenever left turns are restricted to buses and high-occupancy vehicles only during periods of ramp metering.*

Standard:

05 **The LEFT (RIGHT OR CENTER) LANE DO NOT STOP (BUSES ONLY) (R88(CA)) sign shall be used for preferential lanes at metered on-ramps to indicate that the preferential lane is not required to stop.**

06 **The diamond symbol shall not be utilized on the R88(CA) if the preferential lane is not for HOV usage.**

Guidance:

07 *The R88(CA) sign should be placed on the same side as the preferential lane, upstream of the meter.*

08 *The ALL VEHICLES STOP ON RED (R90-1(CA)) sign should be placed when converting a non-metered preferential lane to a metered operation.*

Option:

09 The R90-1(CA) sign may also be used on new installations where potential for confusion exists.

Standard:

10 **The LEFT (RIGHT OR CENTER) HOV __+ __ OR MORE ONLY WHEN METERED (R91-1(CA)) sign shall be used for preferential lanes at metered on-ramps to clearly indicate the lane and number of persons per vehicle required to use the lane.**

11 **The message "24 HOURS" shall be used instead of "WHEN METERED" if the preferential lane is in effect on a full-time basis.**

Option:

12 An alternate 1 line message, such as "BUSES OK" may also be used in place of "WHEN METERED" on line 6 of the R91-1(CA) sign.

Guidance:

13 *When used, the R91-1(CA) sign should be placed near a diamond symbol pavement marking.*

Figure 2G-1. Preferential Lane Regulatory Signs and Plaques (Sheet 1 of 2)

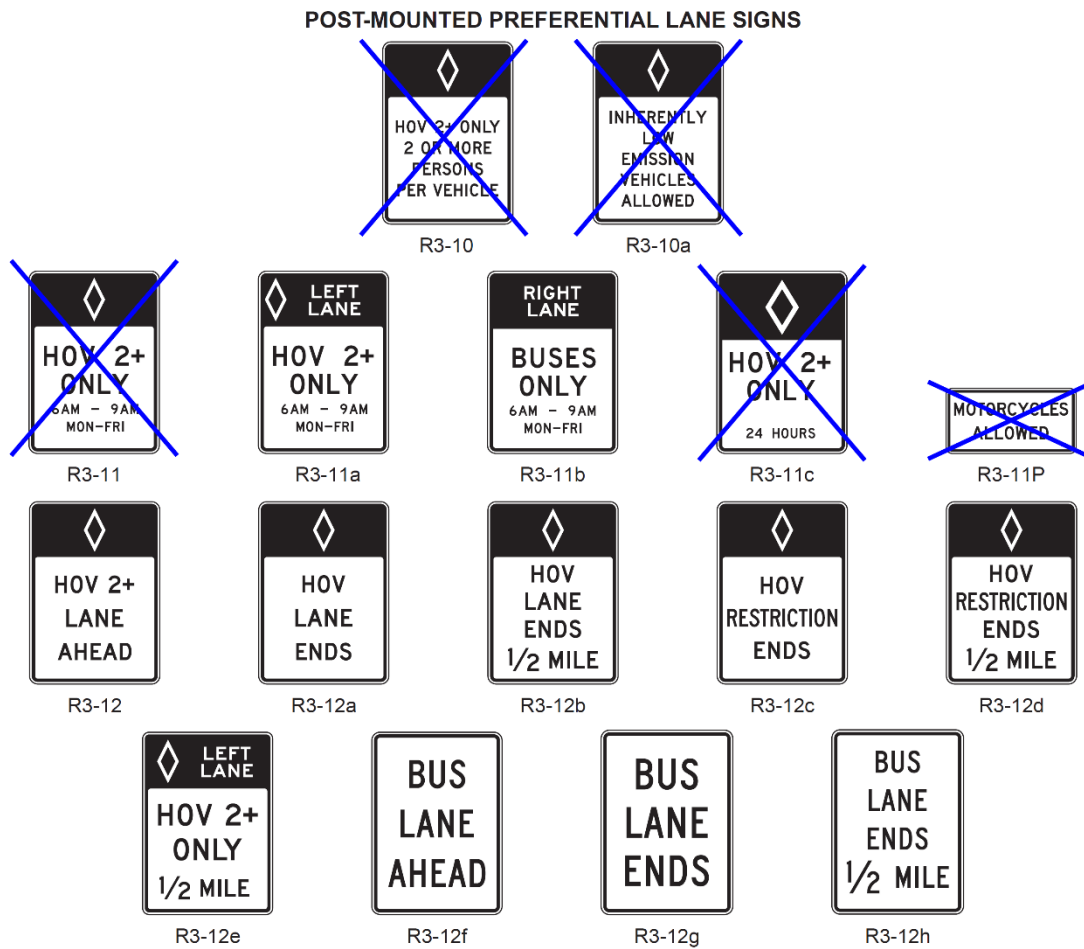

Notes:

1. The minimum vehicle occupancy requirement may vary for each facility (such as 2+, 3+, 4+).
2. The occupancy requirement may be added to the first line of the R3-12a, R3-12b, R3-12c, and R3-12d signs.
3. Some of the legends shown on these signs are for example purposes only. The specific legend for a particular application should be based upon local conditions, ordinances, and State statutes.

Figure 2G-1. Preferential Lane Regulatory Signs and Plaques (Sheet 2 of 2)

OVERHEAD PREFERENTIAL LANE SIGNS

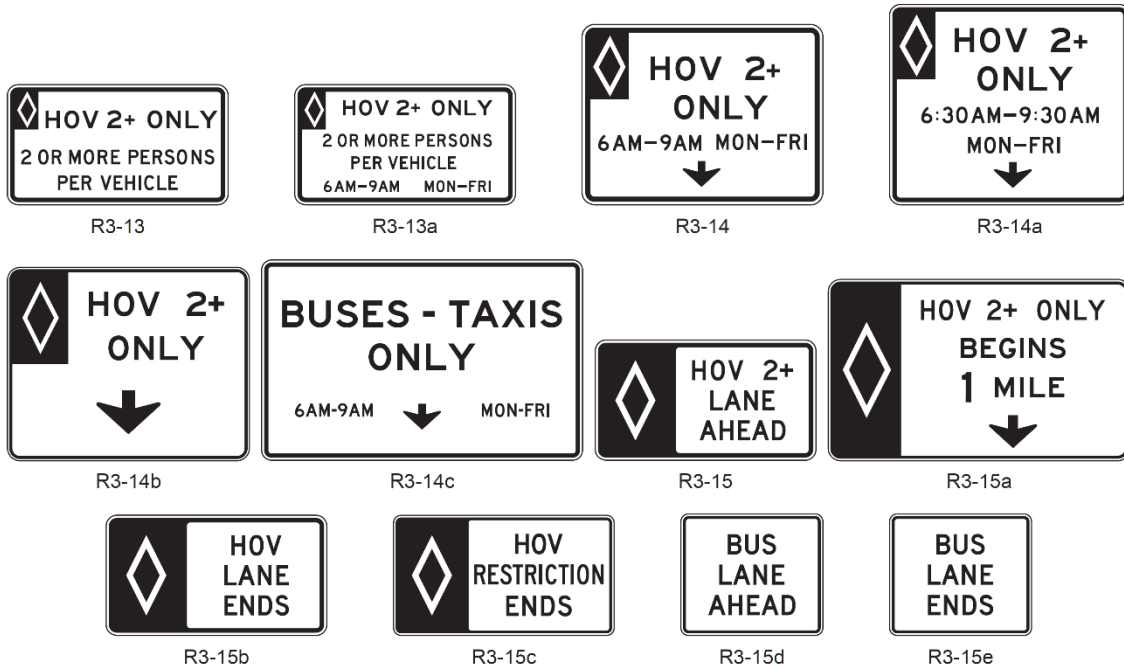

A lane-use control signal may be incorporated into an overhead preferential lane regulatory sign to indicate the status of a reversible operation as shown in the following example:

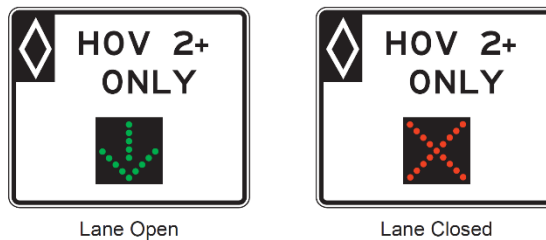

Notes:

1. The minimum vehicle occupancy requirement may vary for each facility (such as 2+, 3+, 4+).
2. The occupancy requirement may be added to the first line of the R3-15b and R3-15c signs.
3. Some of the legends shown on these signs are for example purposes only. The specific legend for a particular application should be based upon local conditions, ordinances, and State statutes.
4. Where sufficient median width is available, the R3-13 series and R3-15 series signs may be post-mounted.

Figure 2G-1 (CA). Preferential Lane Regulatory Signs and Plaques

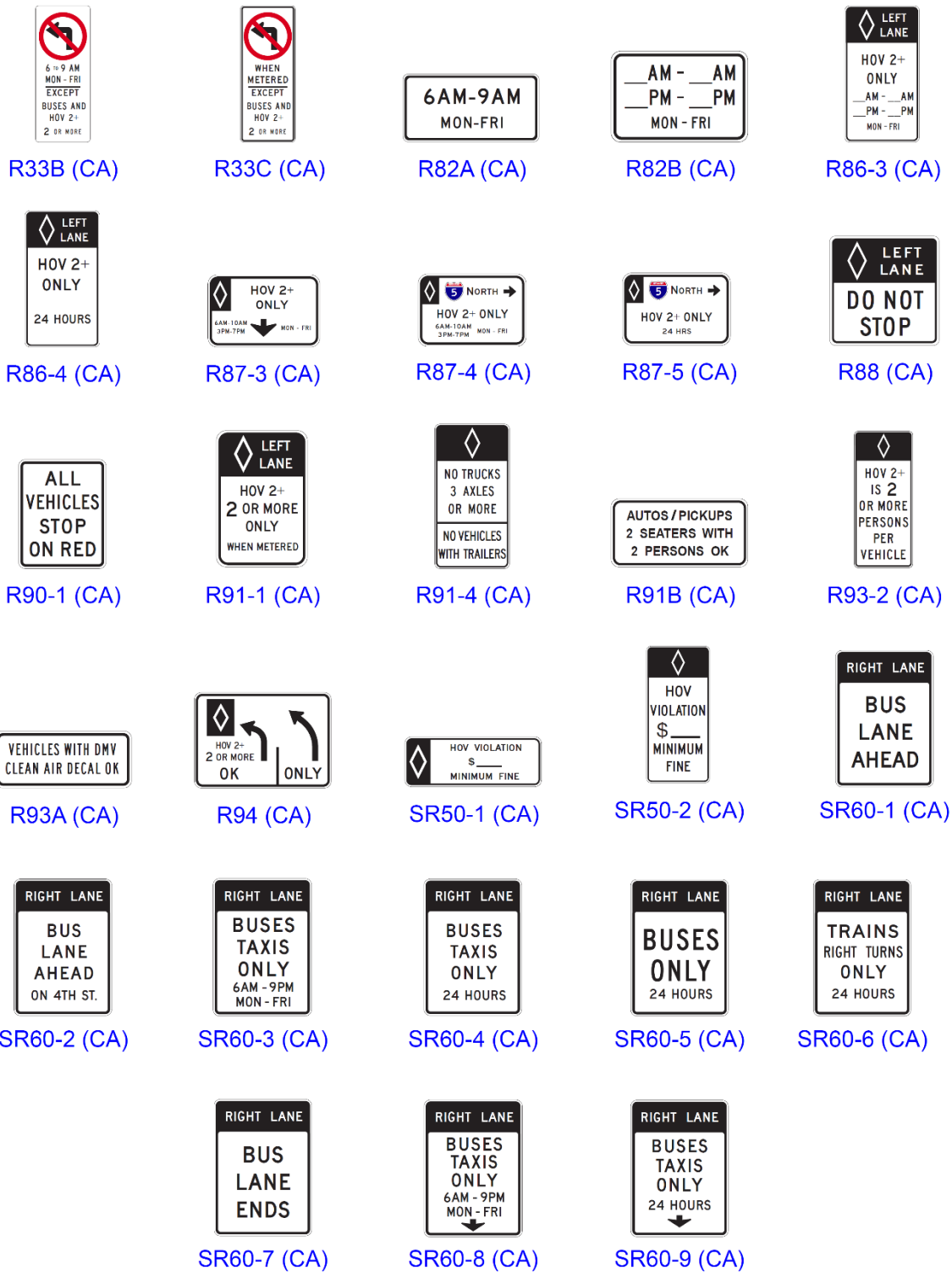

Figure 2G-2. Example of Signing for an Added Continuous-Access Contiguous or Buffer-Separated HOV Lane

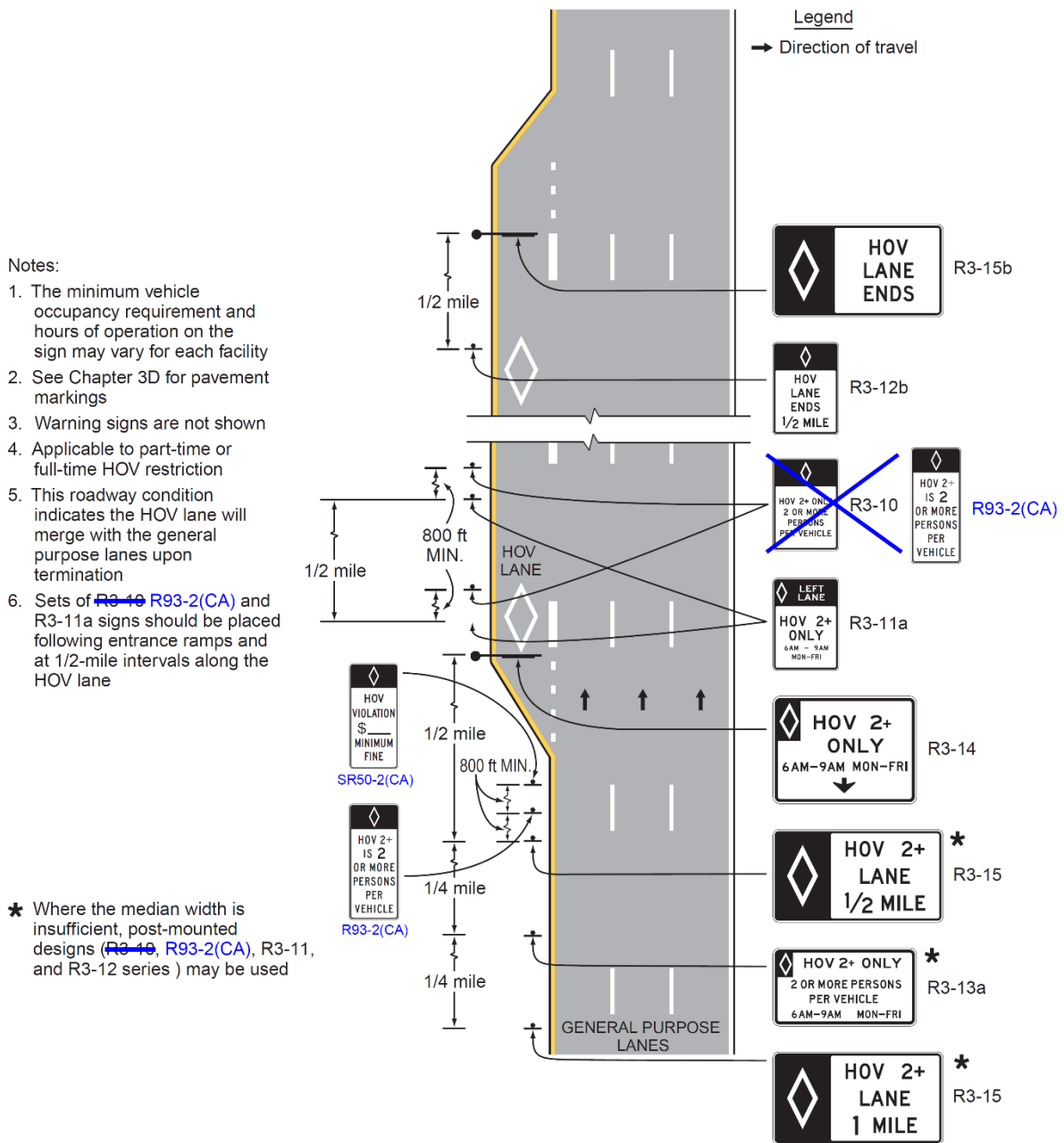

Figure 2G-3. Example of Signing for a General-Purpose Lane that Becomes a Continuous-Access Contiguous or Buffer-Separated HOV Lane

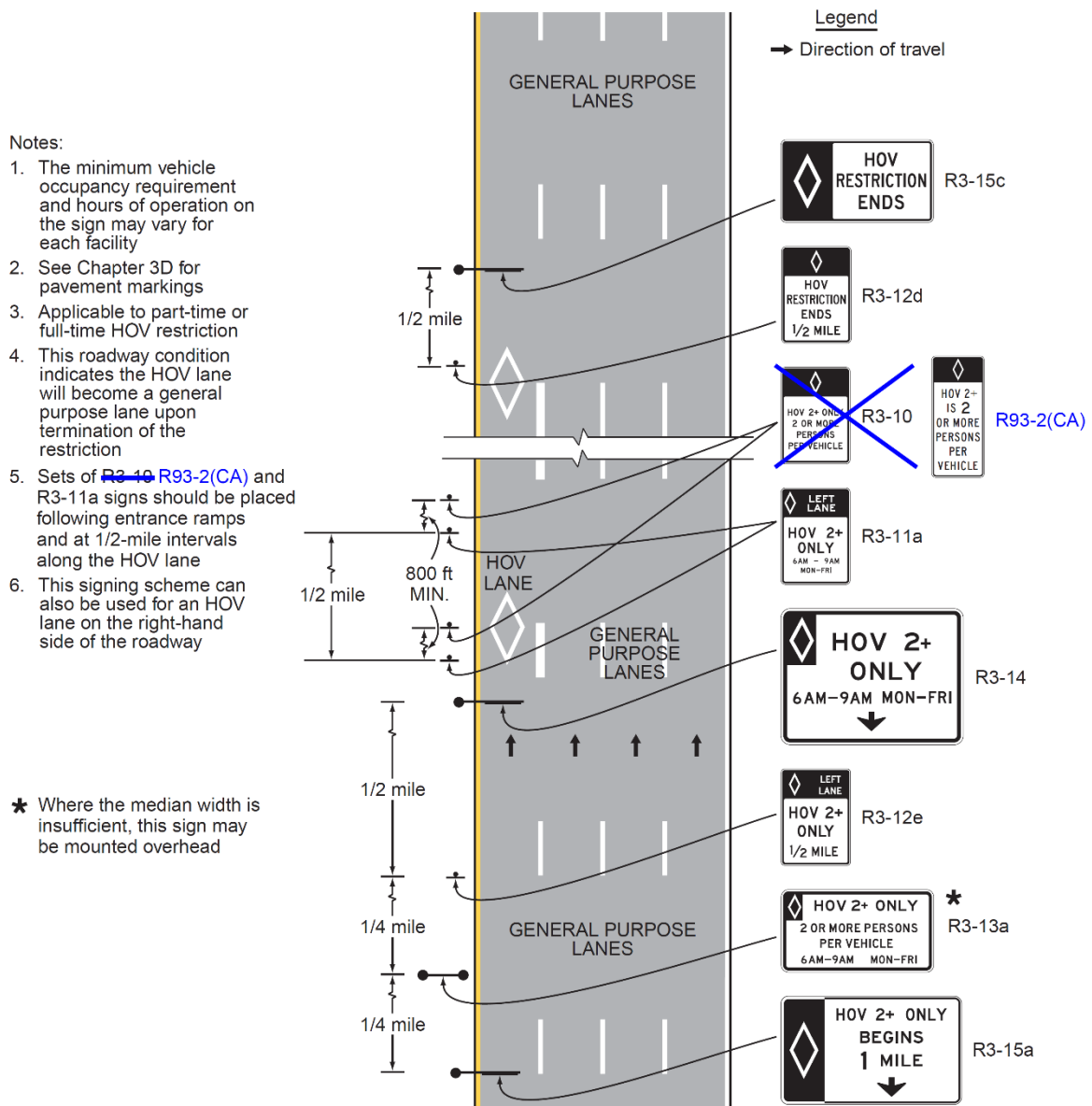
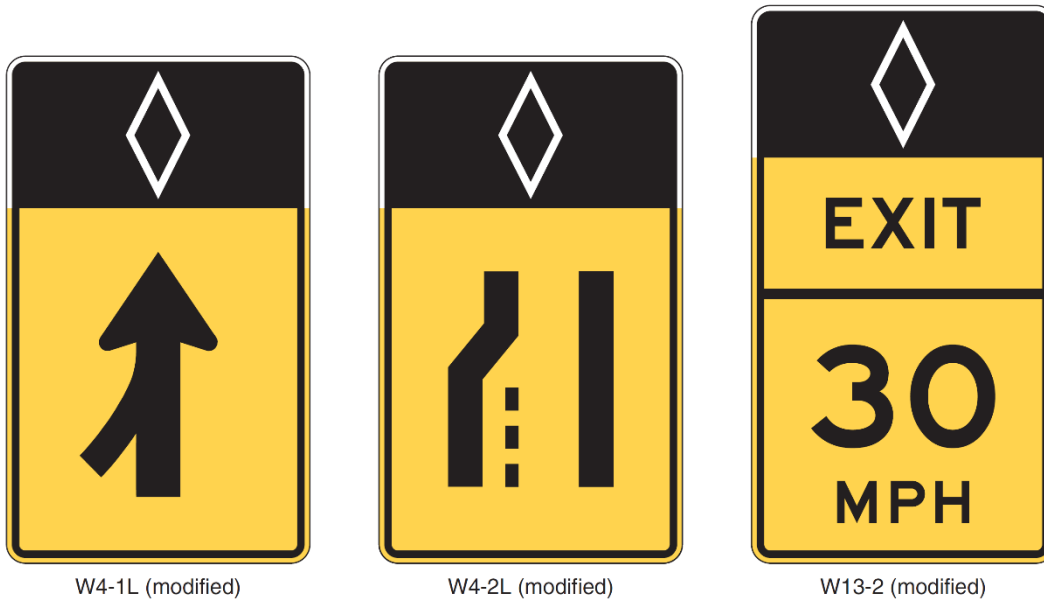

Figure 2G-4. Examples of Warning Signs and Plaques Applicable Only to Preferential Lanes

A - BARRIER-MOUNTED RECTANGULAR WARNING SIGNS



B - WARNING PLAQUE FOR USE ABOVE STANDARD DIAMOND-SHAPED WARNING SIGNS



W16-11P

Note: An HOV lane example (diamond symbol) is illustrated. For other types of preferential lanes, the appropriate symbol or word message (see Section 2G.03) shall be displayed in white on the black background of the top portion of these signs.

Figure 2G-4 (CA). Examples of Warning Signs and Plaques Applicable Only to Preferential Lanes

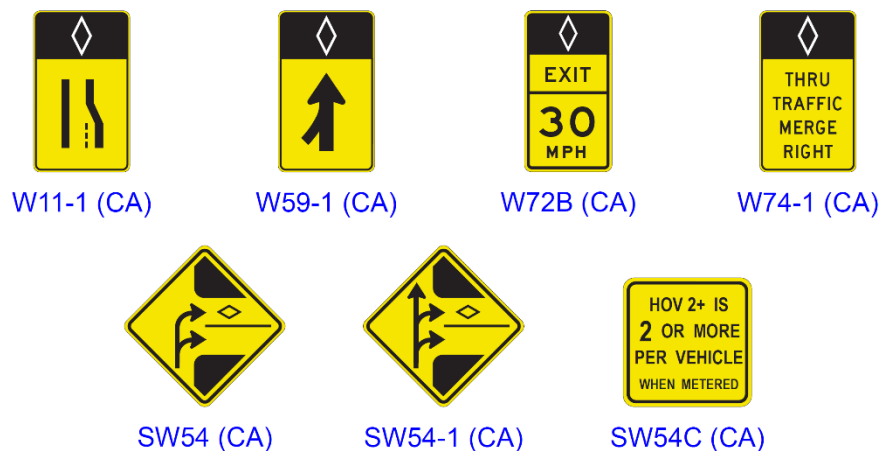

Figure 2G-5. Example of an Overhead Advance Guide Sign for a Preferential Lane Entrance



E8-3

Note: An example of an HOV Lane (diamond symbol) sign is illustrated. For other types of preferential lanes, the appropriate symbol or word message (see Section 2G.03) is displayed in white on the black background of the left-hand portion of this sign.

Figure 2G-6. Examples of Overhead or Post-Mounted Preferential Lane Entrance Direction Signs



E8-2
(overhead only)



E8-2a
(post-mounted only)

A changeable message sign may be incorporated into an overhead preferential lane guide sign to indicate the status of a reversible operation as shown in the following example:



Lane Open



Lane Closed

Note: Examples of HOV Lane (diamond symbol) signs are illustrated. For other types of preferential lanes, the appropriate symbol or word message (see Section 2G.03) is displayed in white on the black background of the top left-hand portion of these signs.

Figure 2G-6 (CA). Guide Signs for Direct Entrances to Preferential Lanes From Another Highway



G92-1 (CA)



G20-9 (CA)

Figure 2G-7. Entrance Gore Signs for Barrier-Separated Preferential Lanes

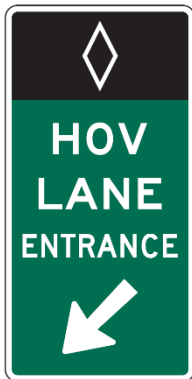

E8-1



E8-1a

Note: Examples of HOV Lane (diamond symbol) signs are illustrated. For other types of preferential lanes, the appropriate symbol or word message (see Section 2G.03) is displayed in white on the black background of the top portion of these signs.

Figure 2G-8. Example of Signing for an Entrance to Access-Restricted HOV Lanes

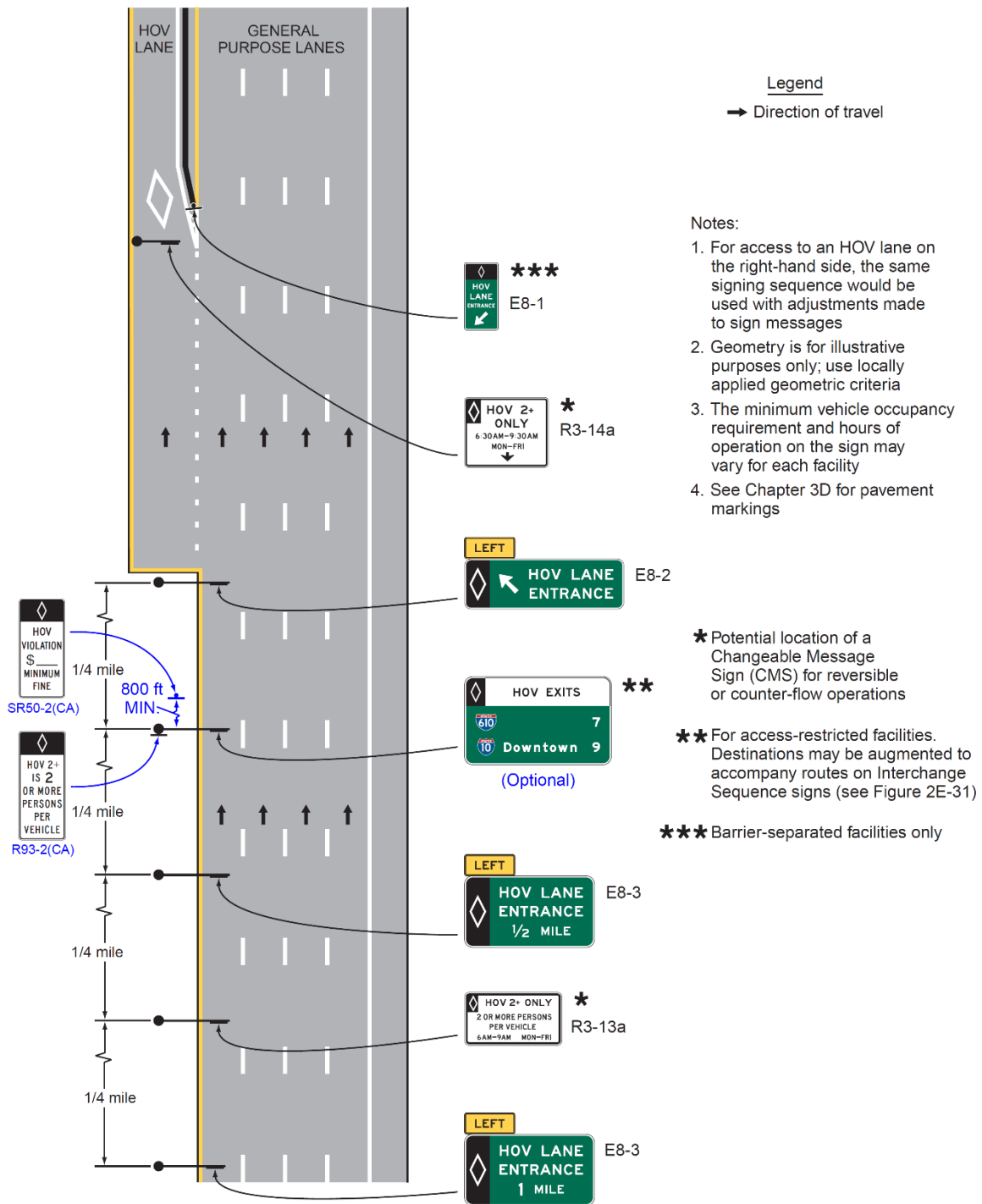

Figure 2G-9. Example of Signing for an Intermediate Entry to a Barrier- or Buffer-Separated HOV Lane

Notes:

1. For access to an HOV lane on the right-hand side, the same signing sequence would be used with adjustments made to sign messages
2. Geometry is for illustrative purposes only; use locally applied geometric criteria
3. The minimum vehicle occupancy requirement and hours of operation on the sign may vary for each facility
4. See Chapter 3D for pavement markings.
5. Warning signs are not shown

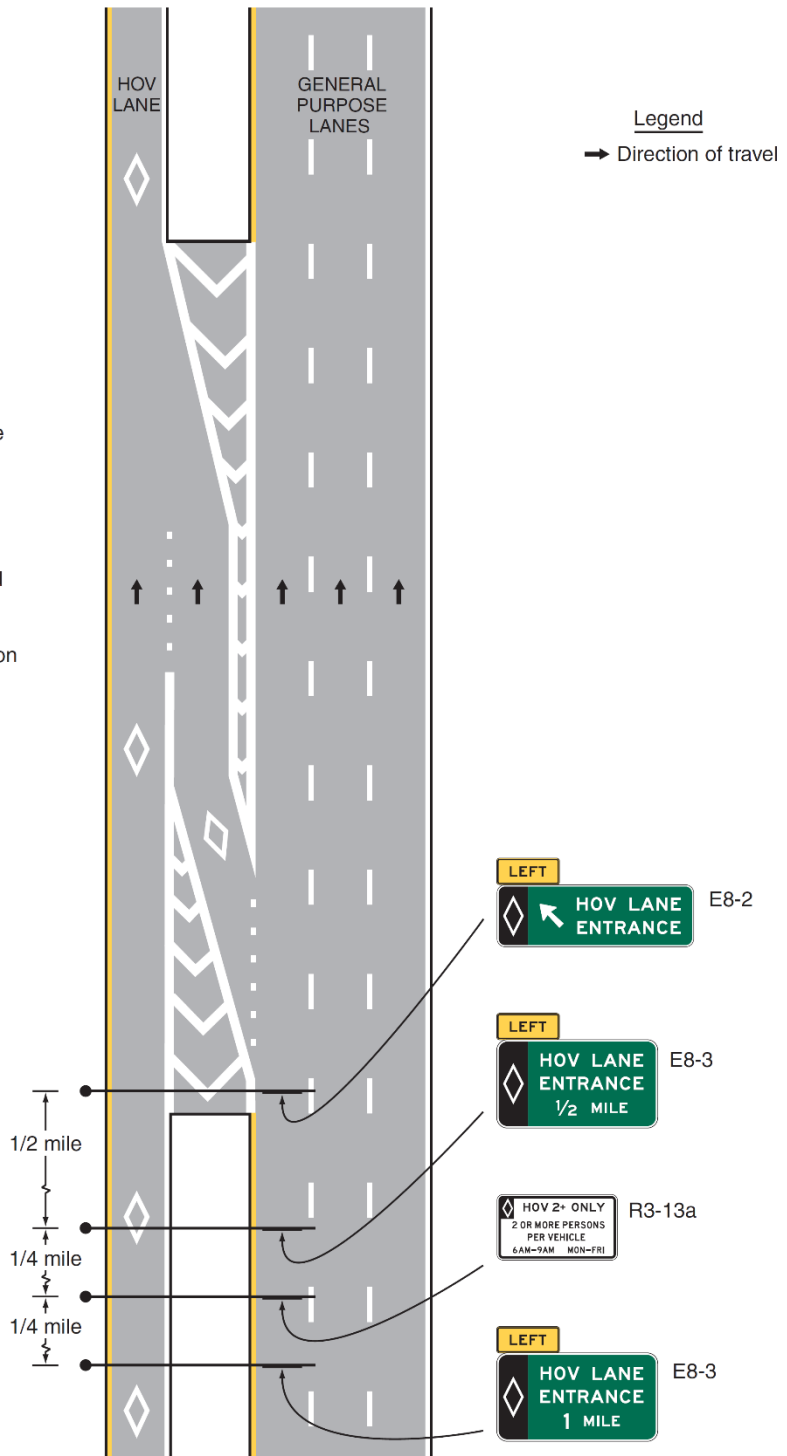

Figure 2G-10. Example of Signing for the Intermediate Entry to, Egress from, and End of Access-Restricted HOV Lanes

Notes:

1. Geometry is for illustrative purposes only; use locally applied geometric criteria
2. The minimum vehicle occupancy requirement and hours of operation on the sign may vary for each facility
3. See Chapter 3D for pavement markings
4. Warning signs are not shown
5. See Figure 2G-2(CA) for additional regulatory signs.
6. This roadway condition indicates the HOV lane will merge with the general purpose lanes upon termination.

★ Barrier-separated facilities only

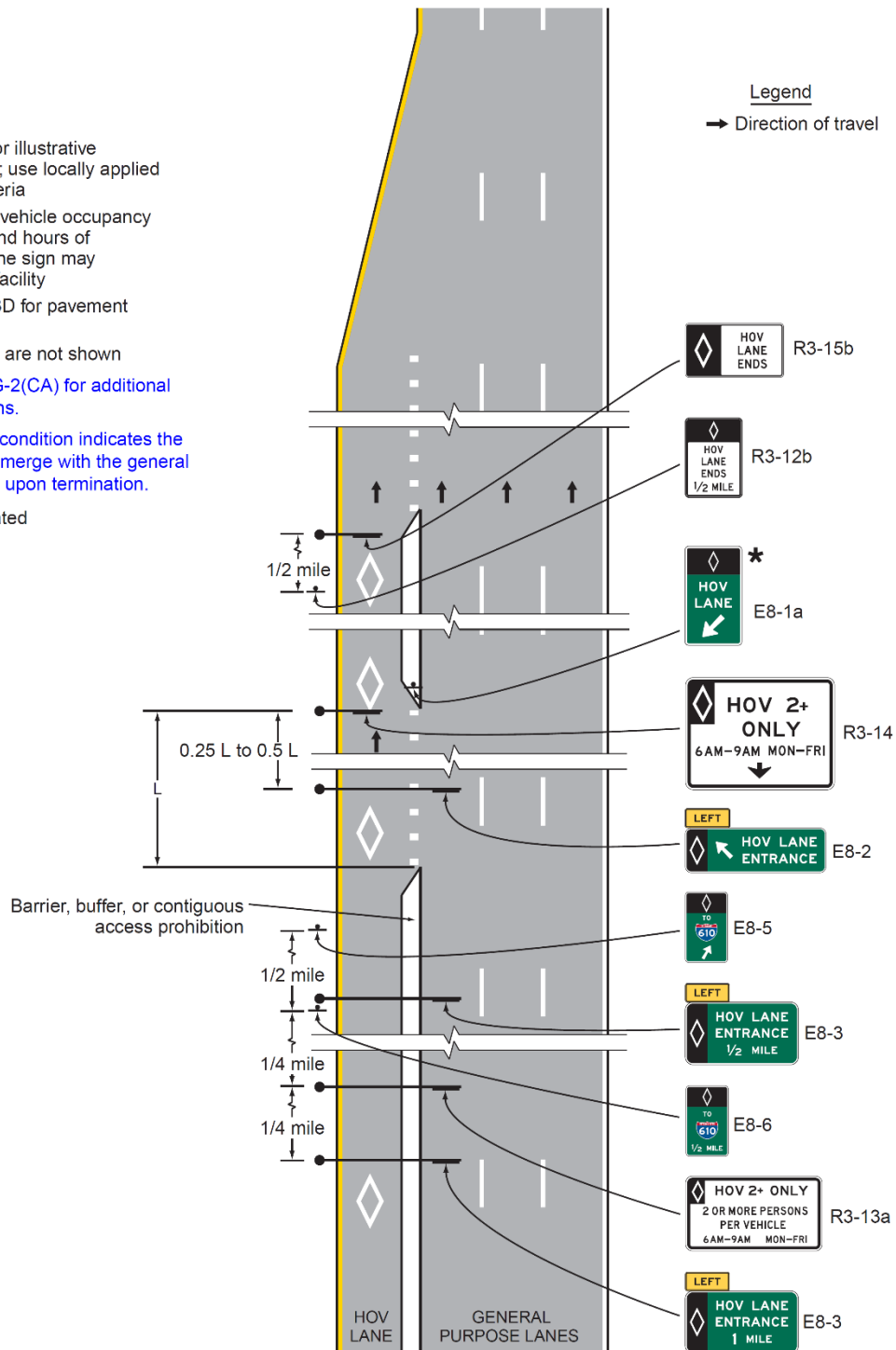
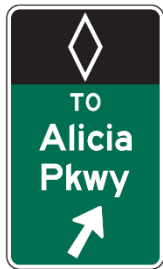
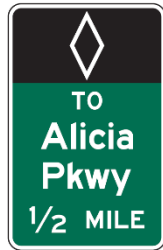

Figure 2G-11. Examples of Barrier-Mounted Guide Signs for an Intermediate Egress from Preferential Lanes



E8-5



E8-6

Note: Examples of HOV Lane (diamond symbol) signs are illustrated. For other types of preferential lanes, the appropriate symbol or word message (see Section 2G.03) is displayed in white on the black background of the top portion of these signs.

Figure 2G-12. Examples of Signs for an Intermediate Egress from a Barrier- or Buffer-Separated HOV Lane

Notes:

1. For an exit on the left-hand side from an HOV lane, the same signing sequence would be used with adjustments made to sign messages
2. Geometry is for illustrative purposes only; use locally applied geometric criteria
3. The minimum vehicle occupancy requirement and hours of operation on the sign may vary for each facility
4. See Sections Chapter 3D for pavement markings
5. Warning signs are not shown

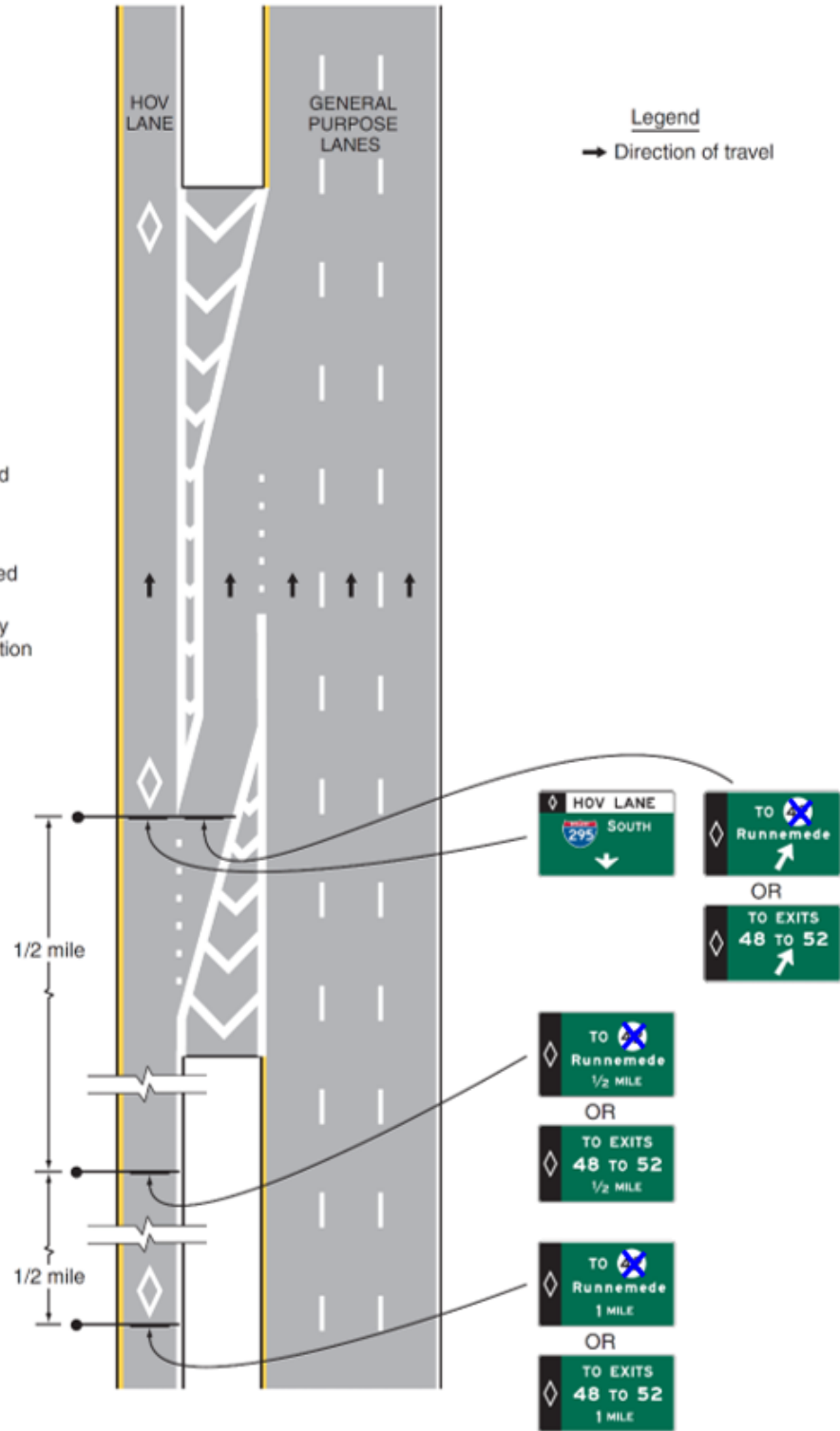

Note: For Guide Sign Assemblies use California State Route (G28-1(CA)) and US Route (G26-1(CA)) shields.

Figure 2G-13. Example of Signing for a Direct Entrance Ramp to an HOV Lane from a Park-and-Ride Facility and a Local Street

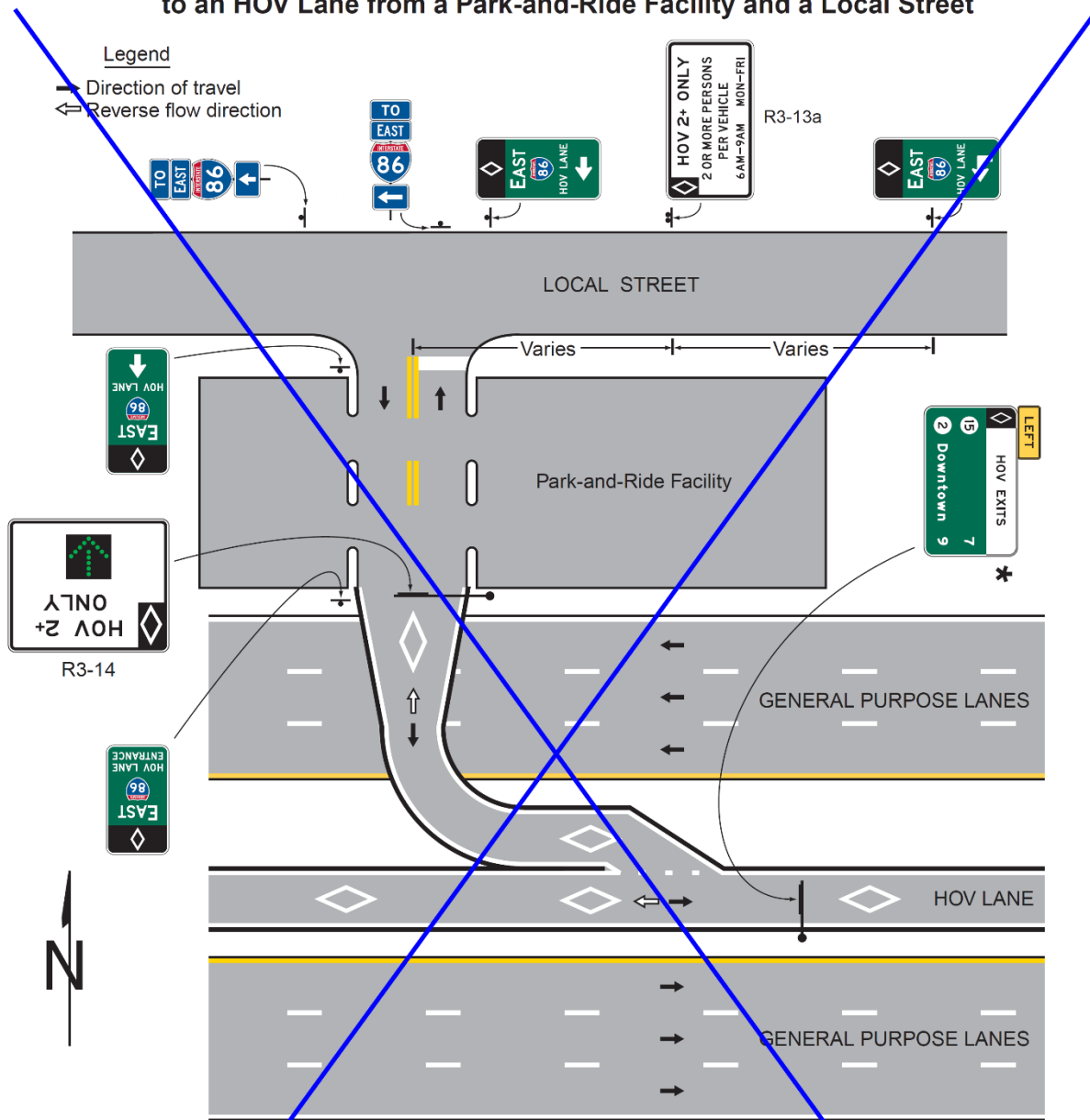

Notes:

1. The minimum vehicle occupancy requirement on the sign may vary for each facility
 2. See Chapter 3D for pavement markings
 3. Warning signs are not shown
 4. Sign locations are approximate
 5. Additional signs may be required to direct drivers from the surrounding streets into the park-and-ride lot and the HOV lane
 6. Additional signs are required on the adjoining surface streets to inform non-HOVs that they should not enter the HOV facility
 7. This figure illustrates a reversible HOV lane with a direct access ramp
 8. The guide signs directing local street traffic to the HOV lane should include the word ENTRANCE when the direct access ramp does not traverse a park-and-ride facility
- * For access-restricted facilities; destinations may be augmented to accompany routes on Interchange Sequence signs (see Figure 2E-31)

Figure 2G-14. Exit Gore Sign for a Direct Exit from a Preferential Lane



E8-4

Note: An example of an HOV Lane (diamond symbol) sign is illustrated. For other types of preferential lanes, the appropriate symbol or word message (see Section 2G.03) is displayed in white on the black background of the top portion of this sign.

Figure 2G-14 (CA). Advanced Guide and Exit Direction Sign for a Direct Exit from a Preferential lane

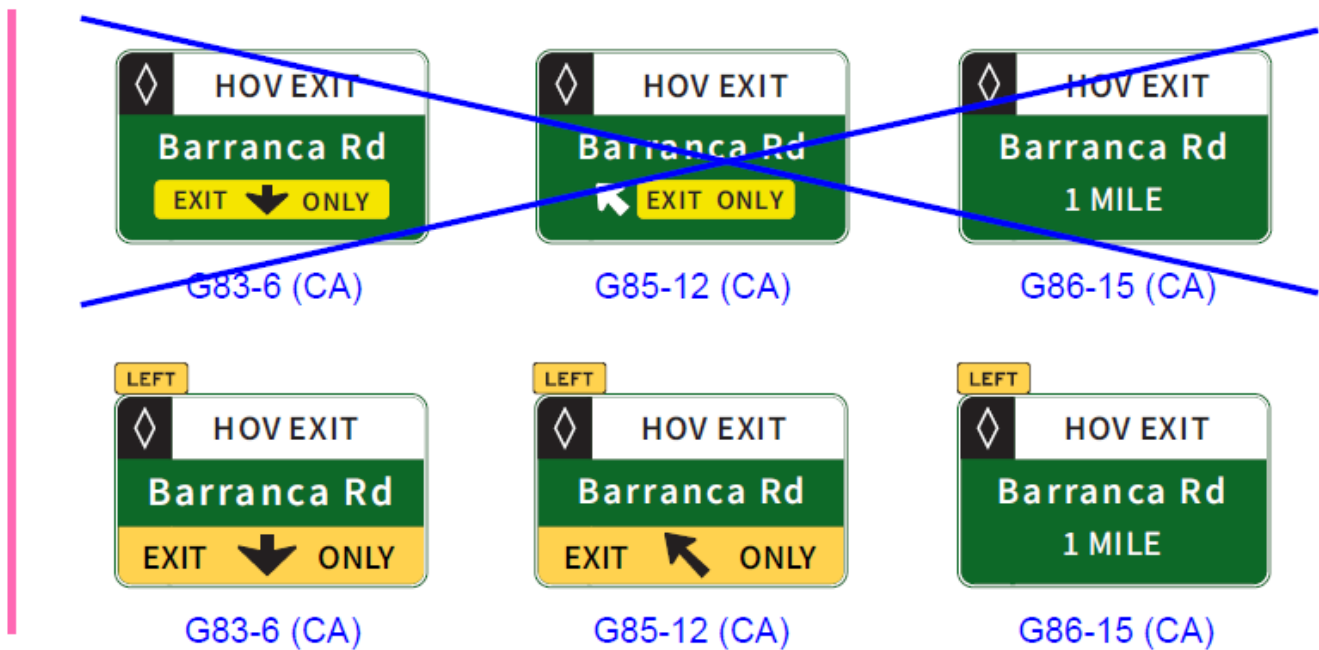

Figure 2G-15. Examples of Guide Signs for Direct HOV Lane Entrance and Exit Ramps

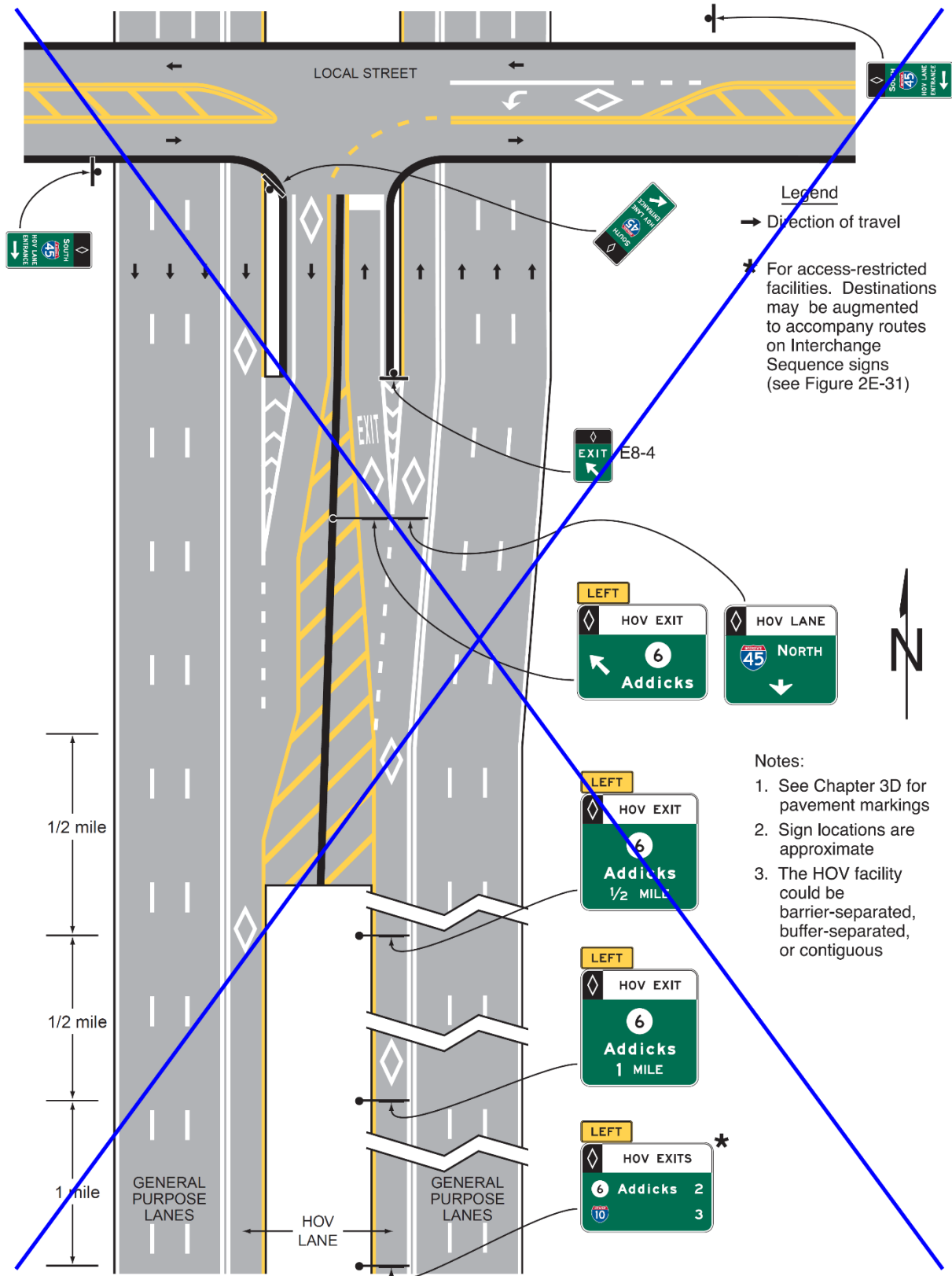
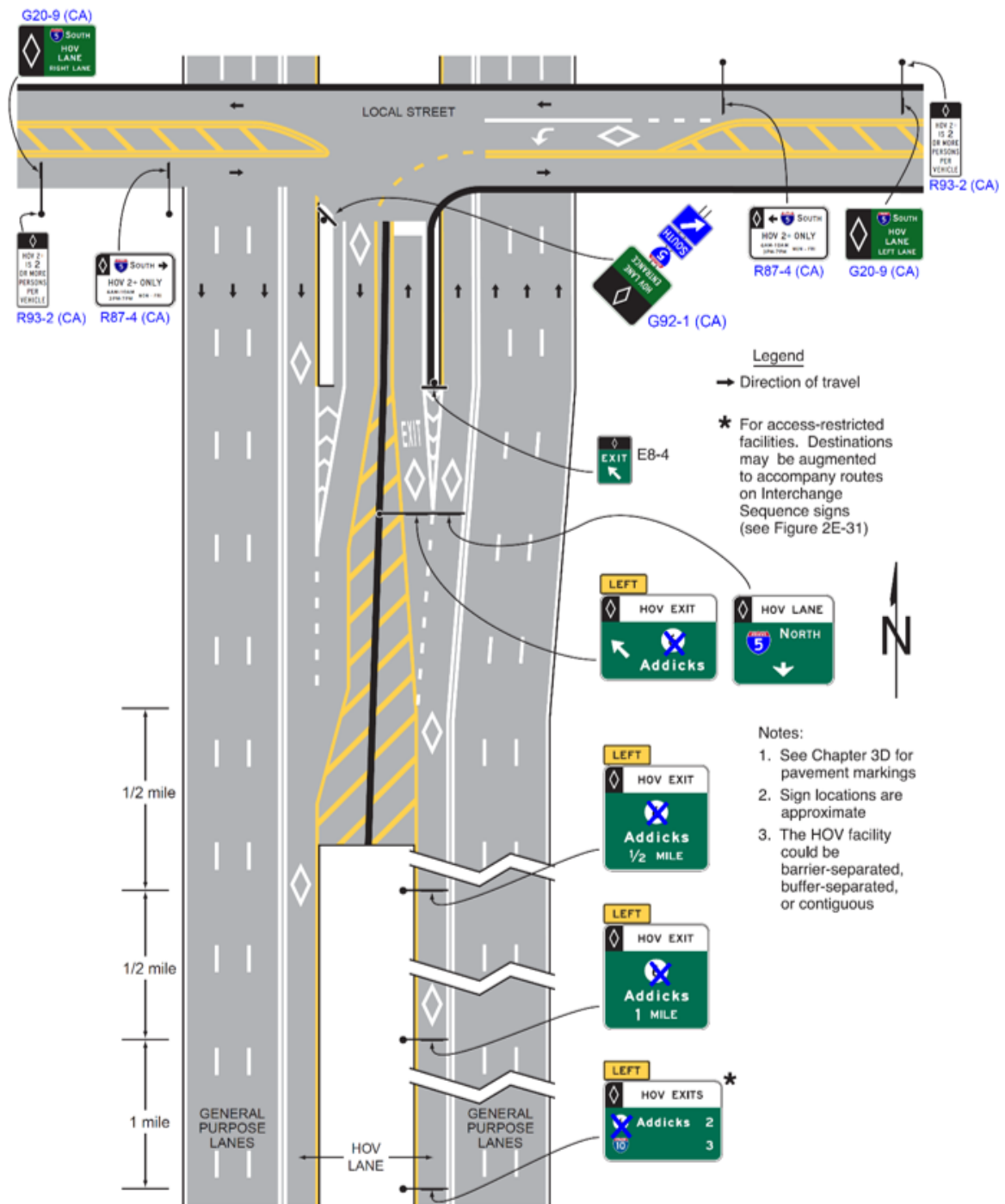
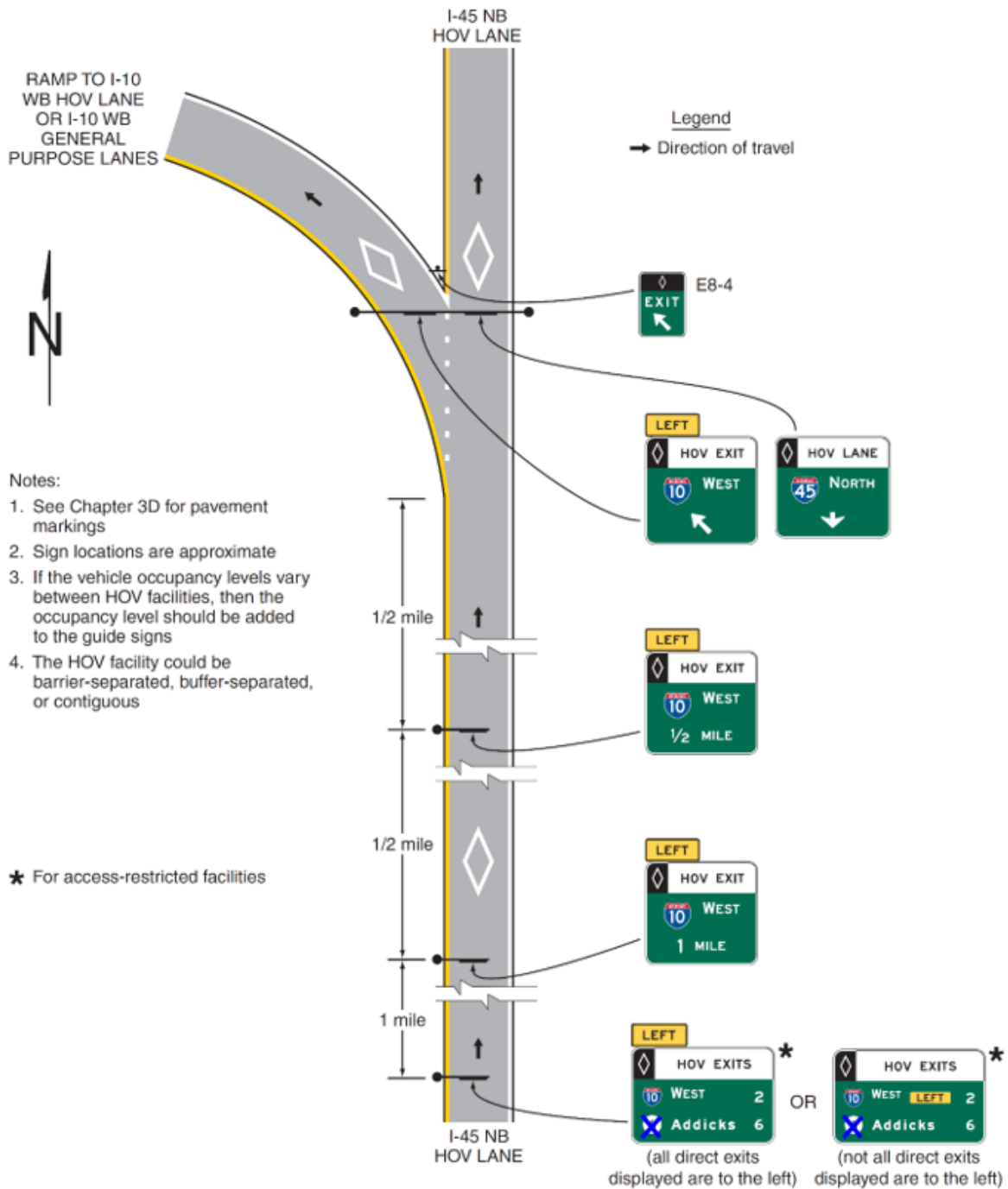

Figure 2G-15 (CA). Example of Guide Signs for Direct HOV Lane Entrance and Exit Ramps



Note: For Guide Sign Assemblies use California State Route (G28-1(CA)) or US Route (G26-1(CA)) shields.

Figure 2G-16. Examples of Guide Signs for a Direct Access Ramp between HOV Lanes on Separate Freeways



Note: For Guide Sign Assemblies use California State Route (G28-1(CA)) or US Route (G26-1(CA)) shields.

Figure 2G-17. Regulatory Signs for Managed Lanes



Notes:

1. The ETC pictograph shown is an example only. The pictograph for the toll facility's adopted ETC system shall be used.
2. Changeable message sign elements shall be used for the numerals displayed for the variable tolls.
3. For Guide Sign Assemblies use California State Route (G28-1(CA)) or US Route (G26-1(CA)) shields.

Figure 2G-18. Examples of Guide Signs for Entrances to Priced Managed Lanes

A - ENTRANCE TO A PRICED MANAGED LANE FROM A GENERAL PURPOSE LANE



B - DIRECT ENTRANCE TO A PRICED MANAGED LANE FROM A CROSSROAD



Note: 1. The ETC pictographs shown are examples only. The pictograph for the toll facility's adopted ETC system shall be used.
 2. The examples shown are for facilities on which registration in a toll account program is required for toll payments.

Figure 2G-19. Example of an Exit Destinations Sign for a Managed Lane

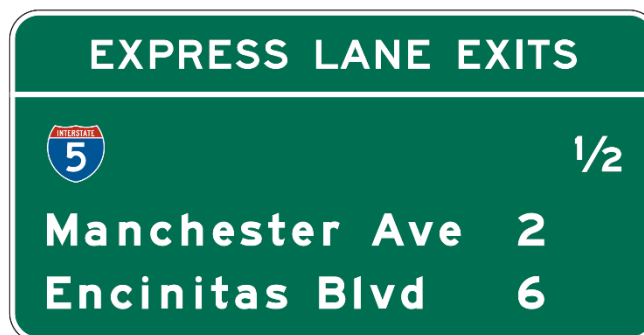
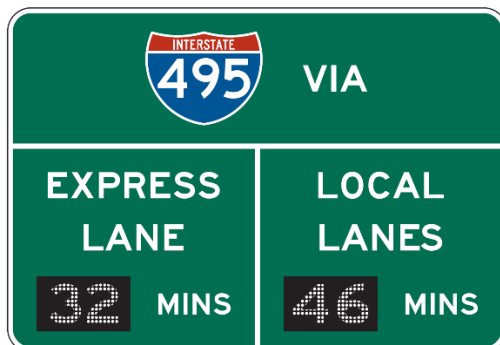

Figure 2G-20. Example of a Comparative Travel Time Information Sign for Preferential or Managed Lanes



Notes:

1. The ETC pictograph shown is an example only. The pictograph for the toll facility's adopted ETC system shall be used.
2. CMS elements shall be used for the numerals displayed for the estimated travel times.

Figure 2G-21. Example of Signing for the Entrance to an Access-Restricted Priced Managed Lane

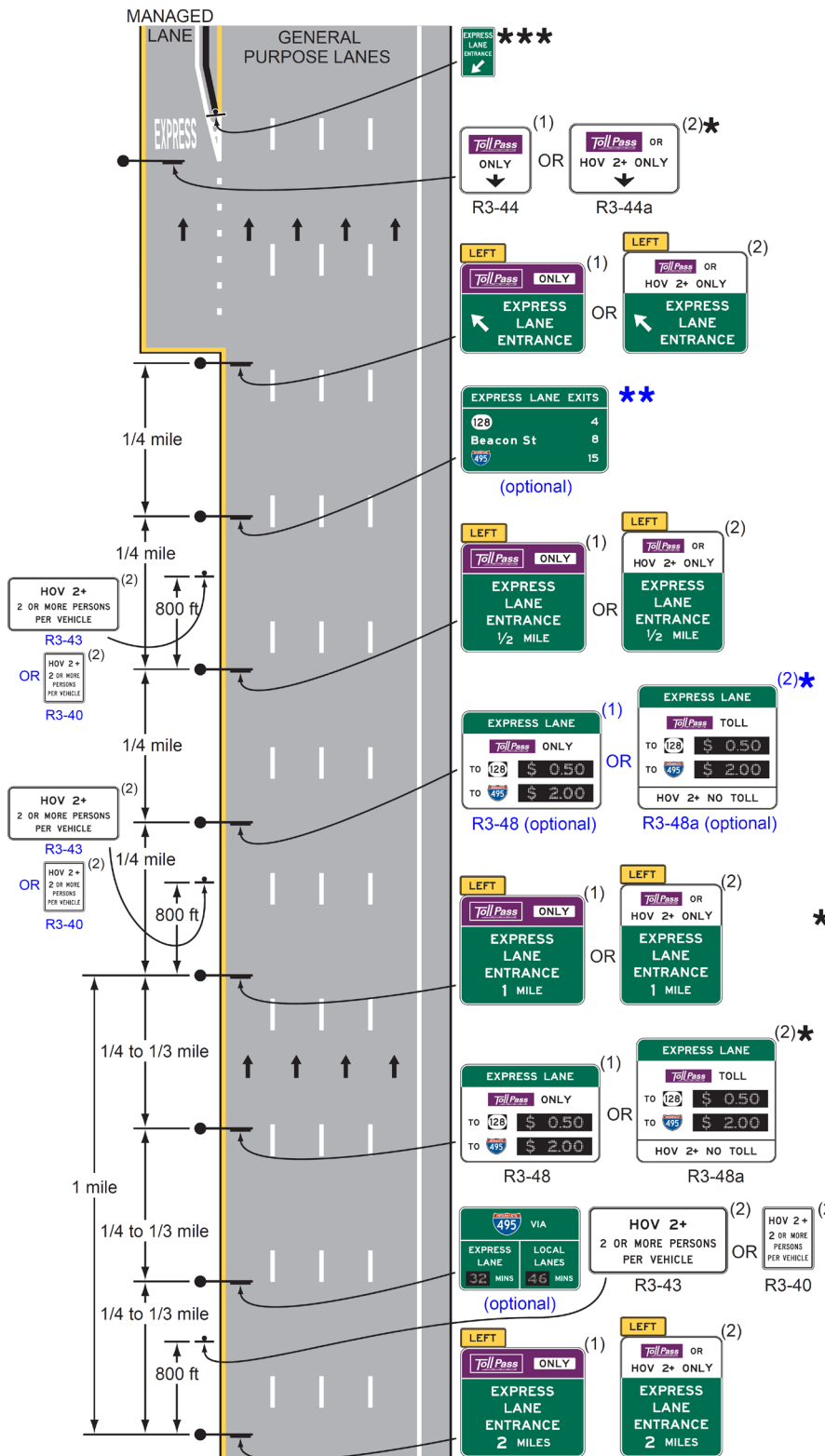

Legend
 → Direction of travel

Notes:

1. For access to a managed lane on the right-hand side, the same signing sequence would be used with adjustments made to sign messages
2. Geometry is for illustrative purposes only; use locally applied geometric criteria
3. The minimum vehicle occupancy requirement and hours of operation on the sign may vary for each facility
4. See Chapter 3D for pavement markings
5. Signs are to be located as described in the section of this manual that applies to the sign

- * Potential location of a Changeable Message Sign (CMS) for reversible or contraflow operations
- ** For access-restricted facilities; destinations may be augmented to accompany routes on Interchange Sequence signs (see Figure 2E-31)
- *** Barrier-separated facilities only

- (1) All vehicles must have a registered ETC account. Toll discounts or exemptions through a registration program might be applicable for certain vehicles.
- (2) All vehicles except HOV must have a registered ETC account. If registration is required for non-toll travel by HOV traffic, case (1) signing shall be used.

Figure 2G-22. Example of Signing for the Entrance to an Access-Restricted Priced Managed Lane Where a General-Purpose Lane Becomes the Managed Lane

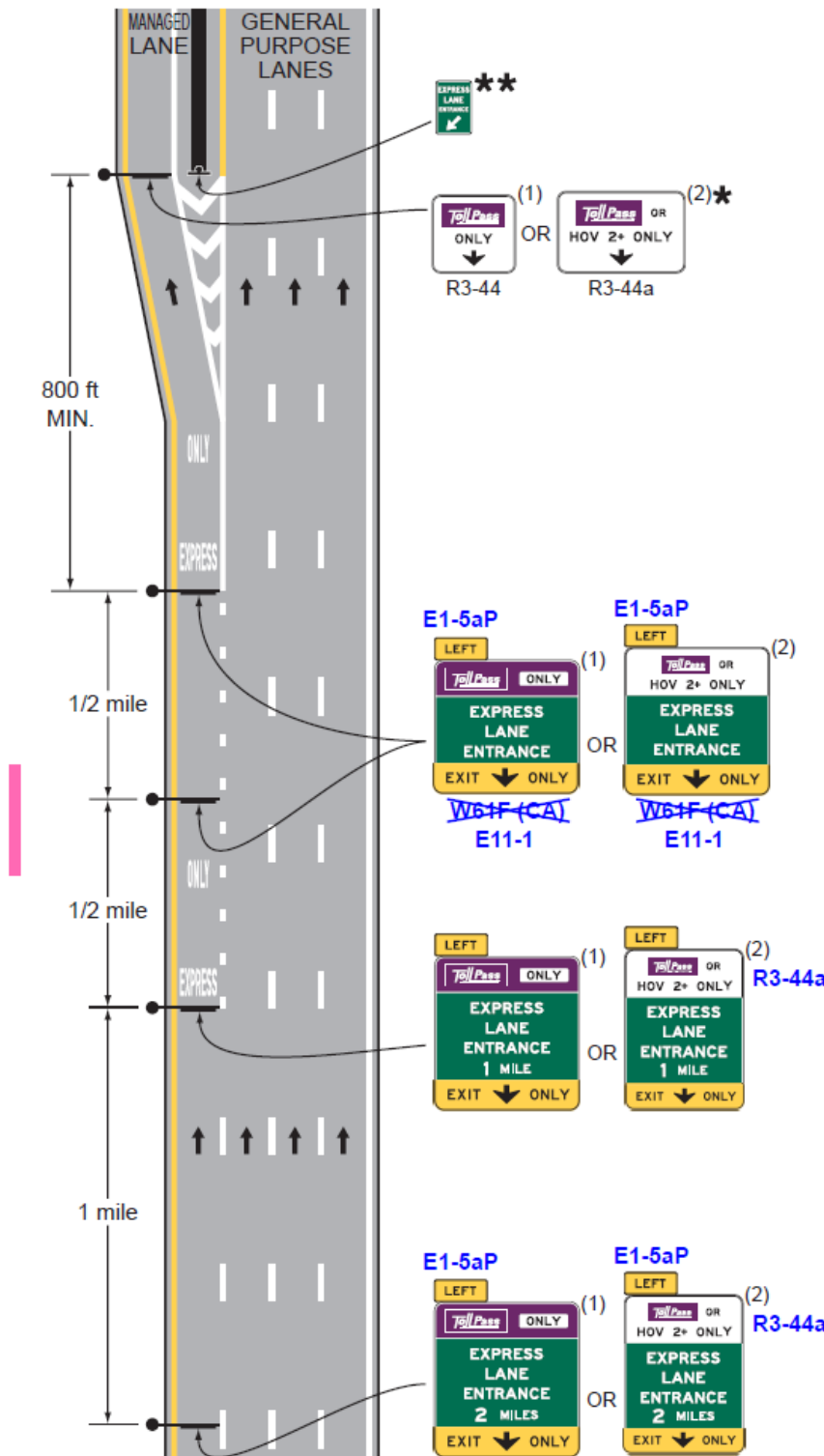

- Legend**
 → Direction of travel
- Notes:**
1. For access to a managed lane on the right-hand side, the same signing sequence would be used with adjustments made to sign messages
 2. Geometry is for illustrative purposes only; use locally applied geometric criteria
 3. The minimum vehicle occupancy requirement and hours of operation on the sign may vary for each facility
 4. See Chapter 3D for pavement markings
 5. See Figure 2G-21 for additional signing
 6. Signs are to be located as described in the section of this manual that applies to the sign
- ★ Potential location of a Changeable Message Sign (CMS) for reversible or contraflow operations
 ★★ Barrier-separated facilities only
- (1) All vehicles must have a registered ETC account. Toll discounts or exemptions through a registration program might be applicable for certain vehicles.
 (2) All vehicles except HOV must have a registered ETC account. If registration is required for non-toll travel by HOV traffic, case (1) signing shall be used.

Figure 2G-23. Example of Signing for an Intermediate Entry to a Barrier- or Barrier-Separated Price Managed Lane

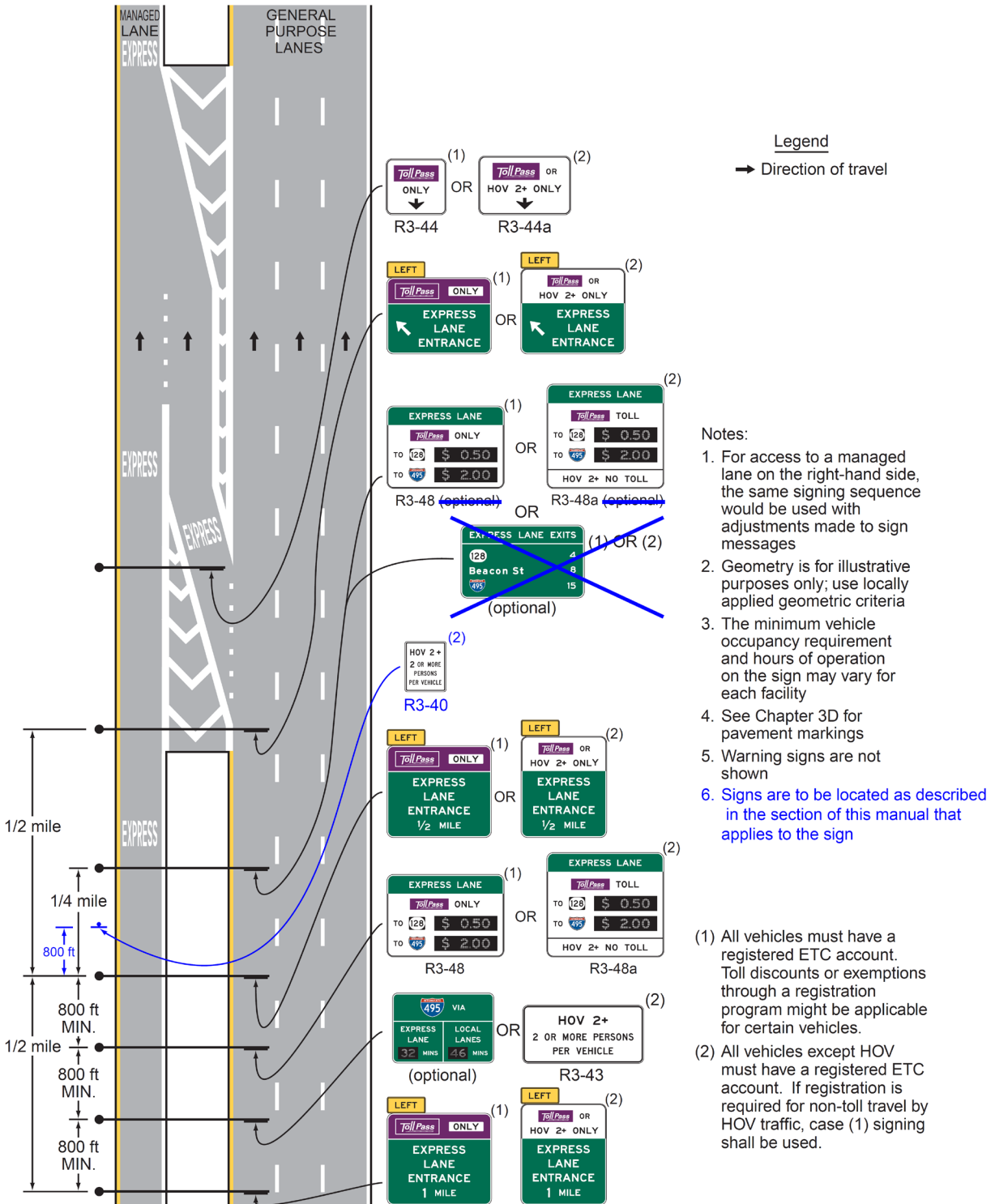

Figure 2G-24. Example of Signing for the Intermediate Entry to, Egress from, and End of Access-Restricted Price Managed Lanes

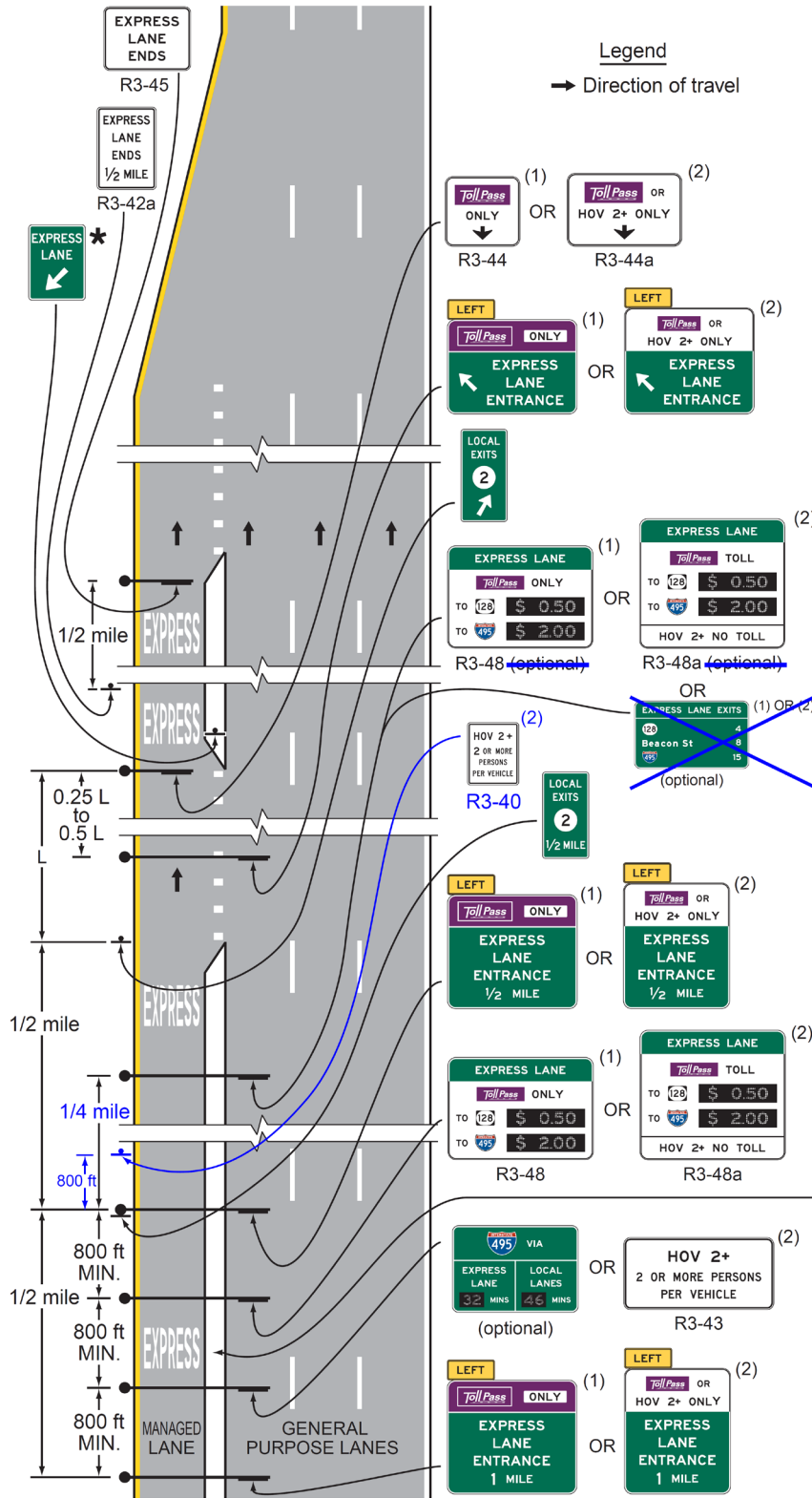
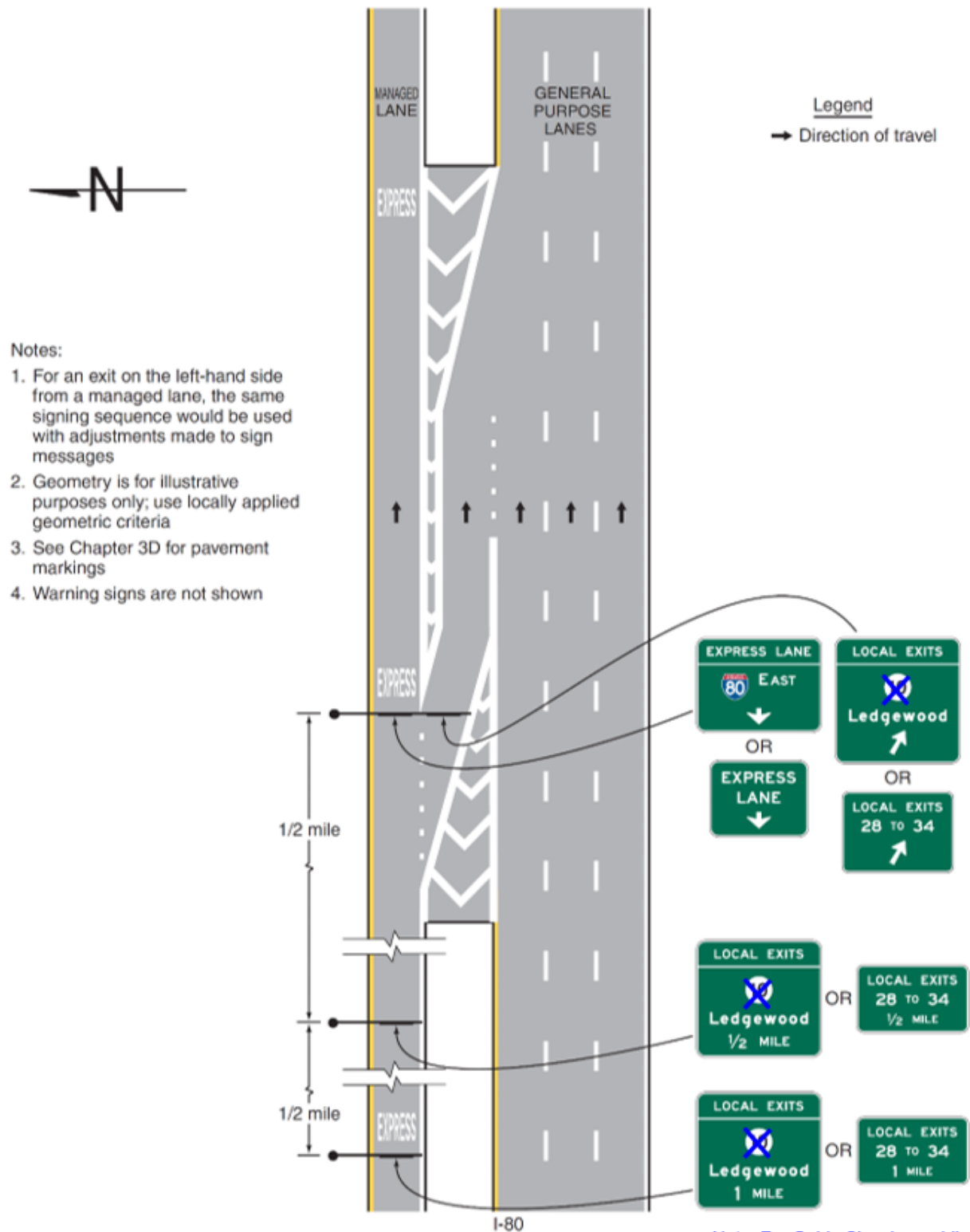

Figure 2G-25. Examples of Guide Signs for an Intermediate Egress from a Barrier- or Buffer-Separated Managed Lane



Note: For Guide Sign Assemblies use California State Route (G28-1(CA)) or US Route (G26-1(CA)) shields.

Figure 2G-26. Examples of Guide Signs for Direct Managed Lane Entrance and Exit Ramps

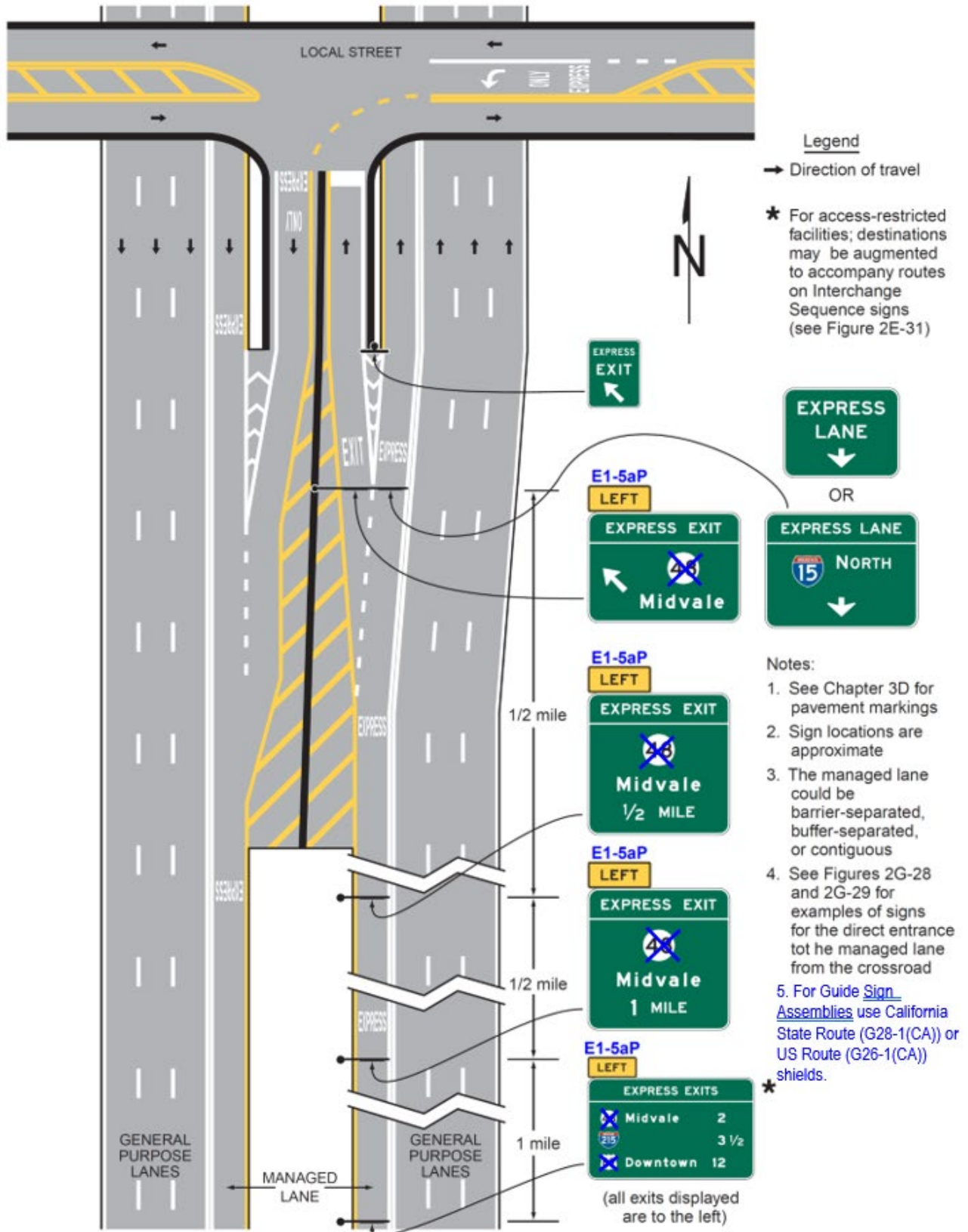

Figure 2G-27. Examples of Guide Signs for a Direct Access Ramp between Managed Lanes on Separate Freeways

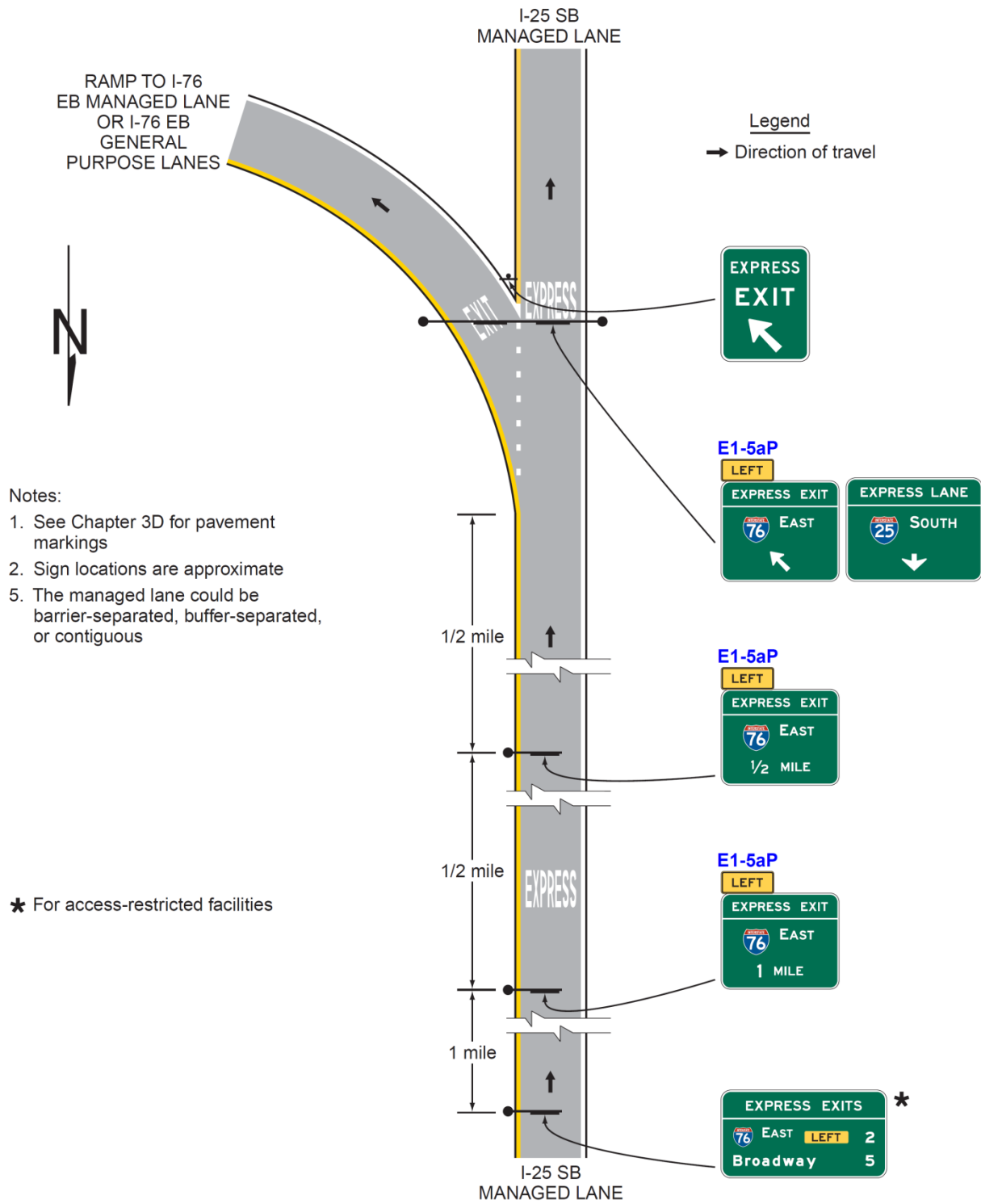

Figure 2G-28. Examples of Guide Signs for a Direct Entrance Ramp to a Priced Managed Lane and Trailblazing to a Nearby Entrance to the General-Purpose Lanes

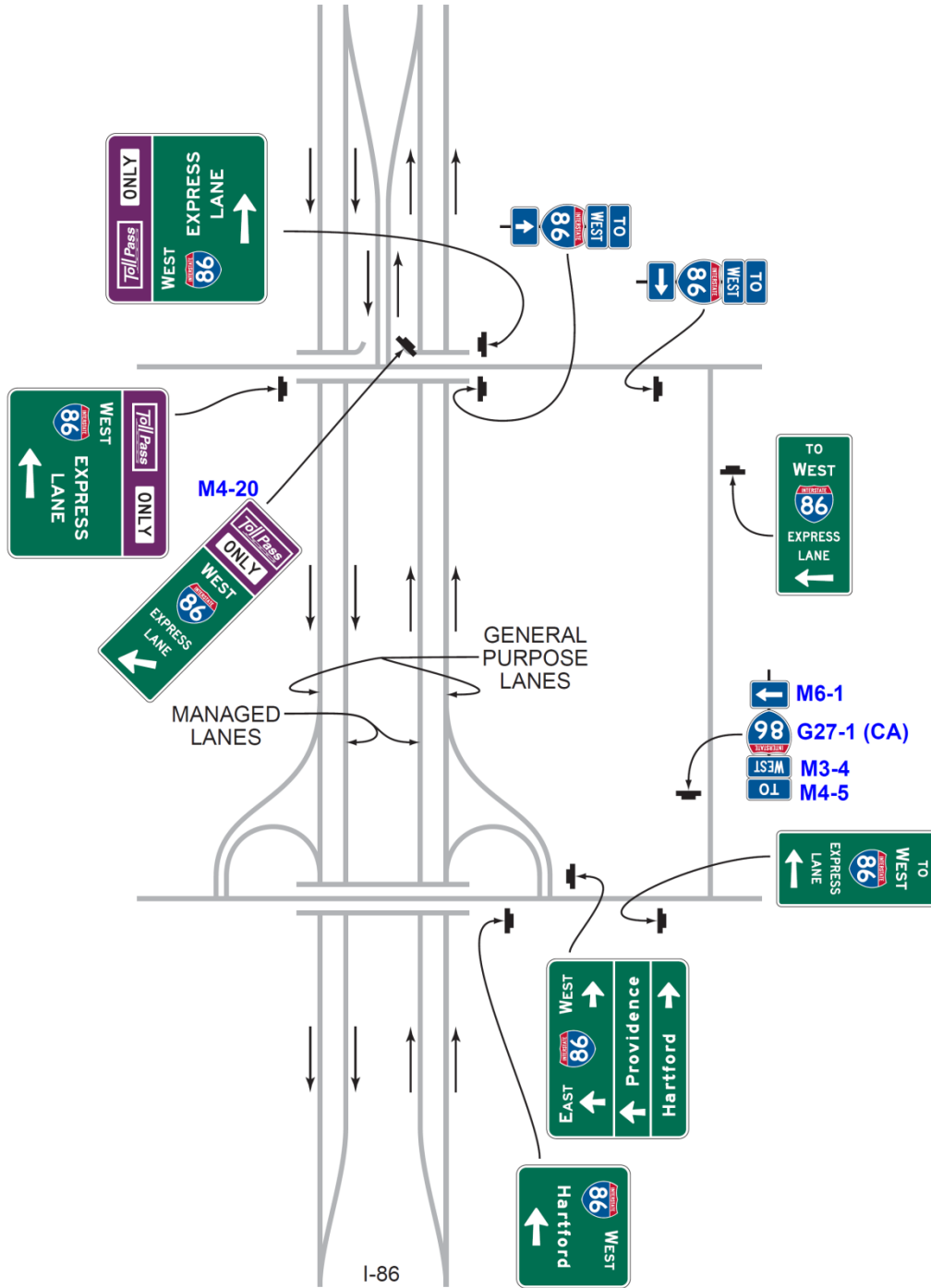

Figure 2G-29. Examples of Guide Signs for Separate Entrance Ramps to General-Purpose and Priced Managed Lanes from the Same Crossroad

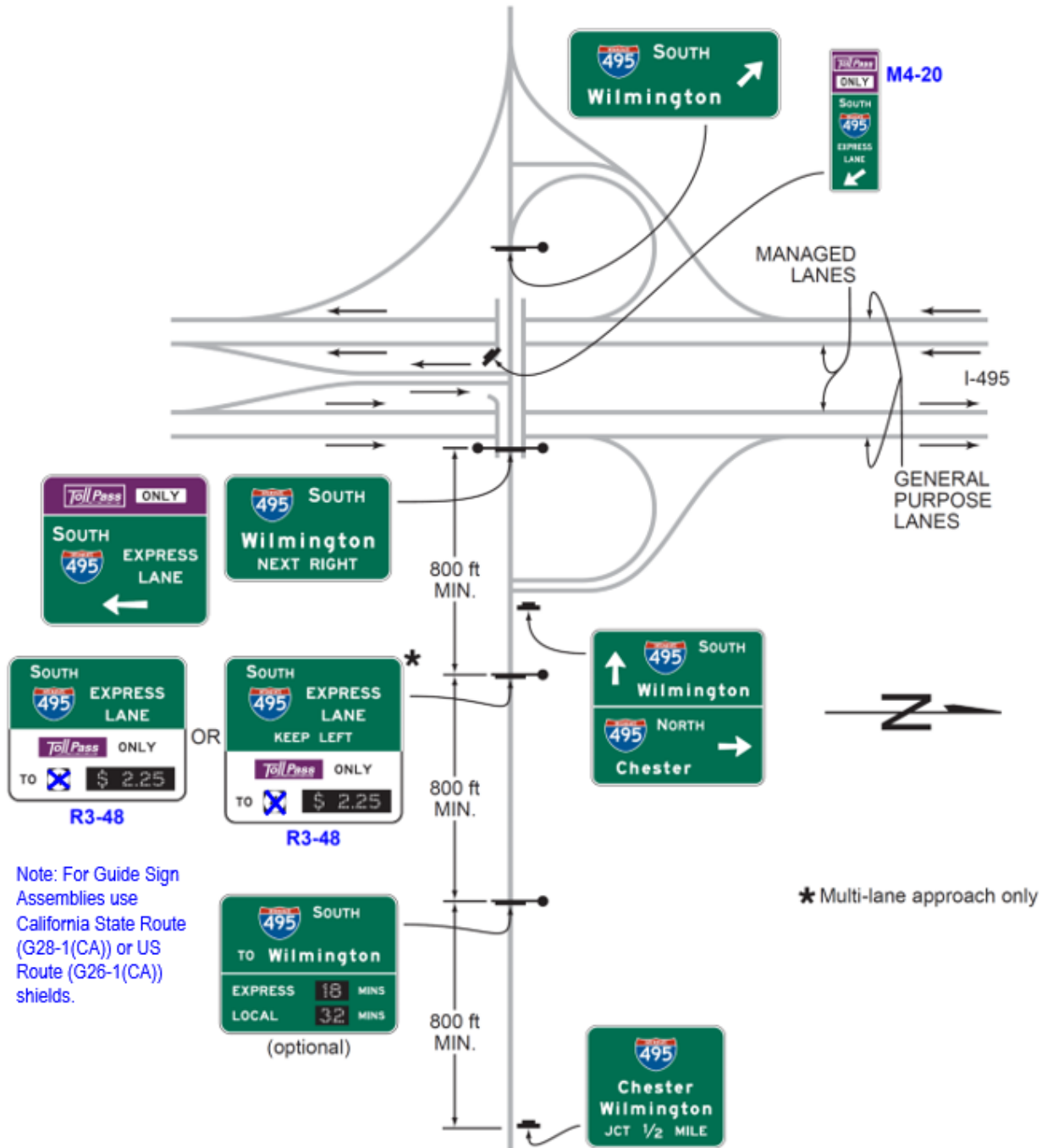

Table 2G-1. Managed and Preferential Lanes Sign and Plaque Minimum Sizes

Sign or Plaque	Sign Designation	Section	Conventional Road		Expressway	Freeway	Oversized
			Single Lane	Multi-Lane			
Preferential Lane Vehicle Occupancy Definition (post-mounted)	R3-10,10a	2G-04	30 x 42	30 x 42	36 x 60	70 x 96	78 x 96
Preferential Lane Periods of Operation (post-mounted)	R3-11 series	2G.05	30 x 42	30 x 42	36 x 60	70 x 96 36 x 60	78 x 96
Motorcycles Allowed (plaque)	R3-11P	2G-05	30 x 42	30 x 42	36 x 60	70 x 96	78 x 96
Preferential Lane Ahead or Ends (post-mounted)	R3-12 series	2G.06	30 x 42	30 x 42	36 x 60	70 x 96 36 x 60	48 x 84
Preferential Lane Vehicle Occupancy Definition (overhead)	R3-13,13a	2G.04	66 x 36	66 x 36	84 x 48	144 x 78	144 x 78
HOV Lane Periods of Operation (overhead)	R3-14,14a,14b	2G.05	72 x 60	72 x 60	96 x 72	144 x 108	144 x 108
Preferential Lane Periods of Operation (overhead)	R3-14c	2G.05	90 x 60	90 x 60	108 x 72	156 x 102	168 x 102
HOV Lane Ahead (overhead)	R3-15	2G.06	66 x 36	66 x 36	84 x 48	102 x 60	102 x 60
HOV Lane Begins XX Miles (overhead)	R3-15a	2G.06	78 x 42	78 x 42	102 x 54	132 x 72	132 x 72
HOV Lane Ends (overhead)	R3-15b,15c	2G.07	66 x 36	66 x 36	84 x 48	102 x 60	102 x 60
Preferential Lane Ahead or Ends (overhead)	R3-15d,15e	2G.07	42 x 36	42 x 36	54 x 48	72 x 60	72 x 60
Priced Managed Lane Vehicle Occupancy Definition (post-mounted)	R3-40	2G.17	—	—	54 x 66	54 x 66	66 x 78
Priced Managed Lane Ends (post-mounted)	R3-42,42b	2G.17	—	—	48 x 60	48 x 60	60 x 78
Priced Managed Lane Ends Advance (post-mounted)	R3-42a,42c	2G.17	—	—	48 x 66	48 x 66	60 x 84
Priced Managed Lane Vehicle Occupancy Definition	R3-43	2G.17	—	—	138 x 66	138 x 66	—
Priced Managed Lane Periods of Operation (overhead)	R3-44	2G.17	—	—	90 x 84	90 x 84	—
Priced Managed Lane Periods of Operation (overhead)	R3-44a	2G.17	—	—	132 x 84	132 x 84	—
Priced Managed Lane Ends (overhead)	R3-45	2G.17	—	—	90 x 66	90 x 66	—
Priced Managed Lane Ends (overhead)	R3-45a	2G.17	—	—	114 x 66	114 x 66	—
Priced Managed Lane Toll Rate	R3-48	2G.17	—	—	Varies	Varies	—
Priced Managed Lane Toll Rate	R3-48a	2G.17	—	—	Varies	Varies	—
HOV (plaque)	W16-11P	2G.09	24 x 12	24 x 12	30 x 18	30 x 18	30 x 18
Preferential Lane Entrance Gore	E8-1	2G.10	—	—	48 x 96	48 x 96	—
Preferential Lane Intermediate Entrance Gore	E8-1a	2G.10	—	—	48 x 84	48 x 84	—
Preferential Lane Entrance Direction (overhead)	E8-2	2G.11	—	—	222 x 72	222 x 72	—
Preferential Lane Entrance Direction (post-mounted)	E8-2a	2G.11	—	—	186 x 108	186 x 108	—
Preferential Lane Entrance Advance	E8-3	2G.11	—	—	186 x 96	186 x 96	—
Preferential Lane Direct Exit Gore	E8-4	2G.15	—	—	60 x 78	60 x 78	—
Preferential Lane Intermediate Egress Direction	E8-5	2G.13	—	—	Varies x 90	Varies x 90	—
Preferential Lane Intermediate Egress Advance	E8-6	2G.13	—	—	Varies x 84	Varies x 84	—

Notes: 1. Larger signs may be used when appropriate
 2. Dimensions in inches are shown as width x height

Table 2G-1(CA). California Managed and Preferential Lanes Sign and Plaque Minimum Sizes (Sheet 1 of 2)

Sign or Plaque	Sign Designation	Section	Conventional Road		Expressway	Freeway	Oversized
			Single Lane	Multi-Lane			
HOV Advance Lane Assignment	G20-9(CA)	2G.14	108 x 72	108 x 72	108 x 72	---	---
HOV Advance Guide	G83-6(CA)	2G.15	---	---	---	---	---
HOV Exit Direction	G85-12(CA)	2G.15	---	---	---	---	---
HOV Supplemental Destination	G86-15(CA)	2G.15	---	---	---	---	---
HOV LANE ENTRANCE	G92-1(CA)	2G.14	36 x 36	36 x 36	48 x 42	---	---
No Left Turn Specific Hours EXCEPT BUSES AND HOV ___+	R33B(CA)	2G.102(CA)	24 x 60	24 x 60	---	---	---
No Left Turn WHEN METERED EXCEPT BUSES AND HOV ___+	R33C(CA)	2G.102(CA)	24 x 60	24 x 60	---	---	---
Specific Hours/Days Plaque	R82A(CA)	2G.06	30 x 12	30 x 12	36 x 18	36 x 18	48 x 24
Specific Hours/Days Plaque	R82B(CA)	2G.06	30 x 24	30 x 24	36 x 24	36 x 24	48 x 36
LEFT LANE HOV ___+ ONLY Specific Hours/Days	R86-3(CA)	2G.05	30 x 66	30 x 66	36 x 66	36 x 66	48 x 78
LEFT LANE HOV ___+ ONLY 24 HOURS	R86-4(CA)	2G.05	30 x 66	30 x 66	36 x 66	36 x 66	48 x 78
HOV ___+ ONLY Specific Hours/Days	R87-3(CA)	2G.05	90 x 60	90 x 60	108 x 70	108 x 70	108 x 70
Route Shield HOV ___+ ONLY Specific Hours/Days	R87-4(CA)	2G.05	104 x 70	104 x 70	---	---	---
Route Shield HOV ___+ ONLY 24 HOURS	R87-5(CA)	2G.05	104 x 70	104 x 70	---	---	---
LEFT (CENTER OR RIGHT) LANE DO NOT STOP (BUSES ONLY)	R88(CA)	2G.102(CA)	30 x 30	30 x 30	---	---	---
ALL VEHICLES STOP ON RED	R90-1(CA)	2G.102(CA)	24 x 30	24 x 30	---	---	---
LEFT (CENTER OR RIGHT) LANE HOV ___+ ___ OR MORE ONLY WHEN METERED (24 HOURS)	R91-1(CA)	2G.102(CA)	30 x 54	30 x 54	---	---	---
(HOV) NO TRUCKS 3 AXLES OR MORE - NO VEHICLES WITH TRAILERS	R91-4(CA)	2G.04	36 x 66	36 x 66	36 x 66	36 x 66	48 x 78
AUTOS/PICKUPS 2 SEATERS WITH 2 PERSONS OK	R91B(CA)	2G.04	30 x 18	36 x 18	36 x 18	36 x 18	48 x 24
HOV ___+ IS ___ OR MORE PERSONS PER VEHICLE	R93-2(CA)	2G.04	30 x 72	30 x 72	36 x 84	36 x 84	---
VEHICLES WITH DMV CLEAN AIR DECAL OK	R93A(CA)	2G.04	30 x 12	30 x 12	36 x 15	36 x 15	---
Mandatory/Optional HOV Movement Lane Control	R94(CA)	2G.05	60 x 42	60 x 42	---	---	---
HOV VIOLATION \$ ___ MINIMUM FINE	SR50-1(CA)	2G.101(CA)	---	---	192 x 70	192 x 70	---
HOV VIOLATION \$ ___ MINIMUM FINE	SR50-2(CA)	2G.101(CA)	30 x 66	30 x 66	36 x 78	36 x 78	48 x 96
RIGHT LANE BUS LANE AHEAD	SR60-1(CA)	2G.06	30 x 42	30 x 42	30 x 42	---	---
RIGHT LANE BUS LANE AHEAD ON X ST.	SR60-2(CA)	2G.06	30 x 42	30 x 42	30 x 42	---	---
RIGHT LANE BUSES TAXIS ONLY Specific Hours/Days	SR60-3(CA)	2G.05	30 x 42	30 x 42	30 x 42	---	---
RIGHT LANE BUSES TAXIS ONLY 24 HOURS	SR60-4(CA)	2G.05	30 x 42	30 x 42	30 x 42	---	---
RIGHT LANE BUSES ONLY 24 HOURS	SR60-5(CA)	2G.05	30 x 42	30 x 42	30 x 42	---	---
RIGHT LANE TRAINS RIGHT TURNS ONLY 24 HOURS	SR60-6(CA)	2G.05	30 x 42	30 x 42	30 x 42	---	---
RIGHT LANE BUS LANE ENDS	SR60-7(CA)	2G.07	30 x 42	30 x 42	30 x 42	---	---
RIGHT LANE BUSES TAXIS ONLY Specific Hours/Days w/Downward Arrow	SR60-8(CA)	2G.05	30 x 42	30 x 42	30 x 42	---	---
RIGHT LANE BUSES TAXIS ONLY 24 HOURS w/Downward Arrow	SR60-9(CA)	2G.05	30 x 42	30 x 42	30 x 42	---	---
(HOV) Lane Reduction	W11-1(CA)	2G.08	30 x 60	30 x 60	36 x 60	36 x 60	48 x 72
(HOV) Merge	W59-1(CA)	2G.08	30 x 60	30 x 60	36 x 60	36 x 60	48 x 72
(HOV) Advisory Exit(Ramp) Speed	W72B(CA)	2G.08	36 x 66	36 x 66	48 x 78	48 x 78	60 x 102

Table 2G-1(CA). California Managed and Preferential Lanes Sign and Plaque Minimum Sizes (Sheet 2 of 2)

Sign or Plaque	Sign Designation	Section	Conventional Road		Expressway	Freeway	Oversized
			Single Lane	Multi-Lane			
(HOV) THRU TRAFFIC MERGE LEFT (RIGHT)	W74-1(CA)	2G.08	30 x 60	30 x 60	36 x 60	36 x 60	48 x 72
(HOV) Lane Selection (Left or Right Arrow)	SW54(CA)	2G.08	36 x 36	36 x 36	48 x 48	---	---
(HOV) Lane Selection (Left or Right and Vertical Arrow)	SW54-1(CA)	2G.08	36 x 36	36 x 36	48 x 48	---	---
HOV ___ + IS ___ OR MORE PER VEHICLE WHEN METERED (24 HOURS)	SW54C(CA)	2G.08	30 x 30	30 x 30	36 x 36	---	---